



GE Evolve™

Next Generation Roadway Luminaires & Control Solutions

*Re-imagining roadways for the **future***

current
powered by GE



Street-smart *from the start*

Over a century ago, GE created the first streetlights, and we've been mastering the technology behind roadway fixtures ever since. More than one hundred years and thousands of miles of street lighting later, our passion for innovation still burns bright.



In 1962, GE scientist Dr. Nick Holonyak Jr. invented the first visible LED, leading the way to the next generation of lighting solutions. Today, we have applied our expertise in outdoor fixture and LED systems design to bring you our next generation **GE Evolve™ LED Roadway & High Mast Luminaire** fixtures.

Building on a reputation for excellence that dates back to Edison's first electric light bulb, GE brings a depth of expertise that's unsurpassed in the industry. From day one, we've been here, ready to work with you to provide a solution that helps save energy while bringing greater aesthetics and overall cost savings to city streets and roadways.

*And you can count on **GE** to be there
as we continue to lead the **lighting revolution**.*



Differentiating factors

We've applied the science of light and our expertise in roadway fixtures to integrate application efficiency and reliability into every Evolve ERL & ERHM fixtures. The foundation of our exceptional, high-performance LED roadway lighting solution revolves around GE's custom designs.



optical
design

Unique reflective optic design

- Non-pixelated light distribution to minimize distracting glare
- Optimized to meet IESNA RP-8 recommended practices for luminance, illuminance and small target visibility design
- Excellent light control aims the light directly where you need it
- Low light trespass and zero up-light
- High optical efficiency and utilization of light
- Lower power consumption required for the target roadway space



electrical
design

One manufacturer of complete system

- Reliable GE Lightech™ LED Driver powers the GE Evolve™ LED fixture
- Entire system, including driver, fixture and controls are made, tested and warranted by the same manufacturer to ensure long-term system reliability

Standard surge protection against multiple strikes

- Surge protection against multiple strikes comes standard, with optional high-capacity protection available



mechanical
design

Removable power door assembly

- Makes electrical components easily accessible for replacement or repairs
- Tool-less or single-tool entry and quick connects

Dust & dirt mitigation

- Flat tempered glass lens and IP65 rated enclosed cavity minimize effects of dirt to provide consistent light distribution over the life of the product



reliability &
performance

Extensive testing of the LED, subsystem and complete system

- Conforms to the most stringent regulatory and performance requirements including UL, Design Lights Consortium (DLC) and International Dark-Sky Association (IDA)
- Provides applicable supporting performance documentations such as including TM-21, LM-79 and LM-80 reporting methods
- Rather than rely solely on test data from LED suppliers, we extensively test the complete system to validate performance



controls
capability

Available with wireless network control capability

- GE LightGrid™ Outdoor Wireless Control System allows remote monitoring, utility-grade energy metering and GPS mapping of streetlights
- Adaptive controls ready, without any additional internal electrical components required



Optical design

Aiming to please

GE uses an advanced reflective optic design that meets RP-8 recommended practices for luminance, illuminance and small target visibility. This unique design ensures that Evolve ERL fixtures will deliver light control with significantly less waste than the other optical technologies used by many of our competitors.

Evolve ERL fixtures have improved ratings for backlight, up-light and glare (BUG ratings) to direct more light on the road and not in neighboring properties or in the eyes of nighttime drivers, meeting tight local ordinances and International Dark-Sky (IDA) requirements.

GE

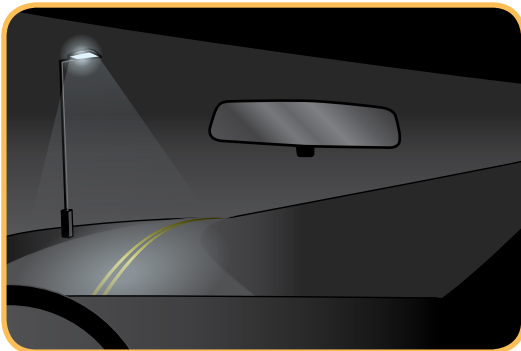

Our unique reflective technology allows us to focus light where it's needed – on the road – with less glare.

COMPETITION

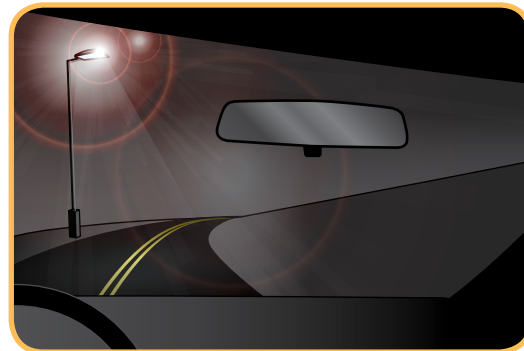

The refractive technology design used by other manufacturers typically results in more wasted light trespass and glare for drivers.

Minimizing glare

GE's innovative reflective design only puts light where it is needed and minimizes direct view of the light source with a non-pixelated appearance.

GE design recesses the LED array within the optic (or reflector) to limit visibility of the LEDs from the drivers' field of view, minimizing glare. Many competing optical designs use LED arrays with individual optics, making the entire array visible to the driver, resulting in a pixelated appearance with higher levels of glare and increased light trespass.



GE

Minimized visibility to LED light source, creating non-pixelated appearance to driver's field of view

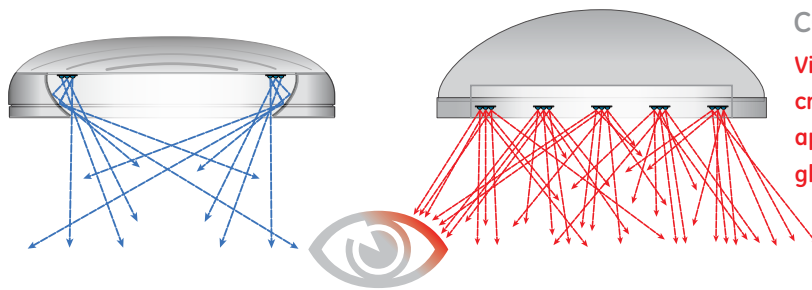

COMPETITION

Visibility to every LED, creating a pixelated appearance and increased glare to driver's field of view

Why is luminance an important focus of GE's optical reflector design?

GE optical design provides outstanding overall visibility while driving, offering reflector optics that were designed with the driver in mind. This design only puts necessary light at and above 45° angles, reducing glare to the driver. GE provides consistent luminance uniformity in the driver's center field of view, while many competing products have greater variation. GE also ensures reduced glare at the critical angles, improving small target visibility which allows drivers to detect objects faster while driving. The uniformity of light in the driver's field of view improves the retina image. Designing for the driver's field of view with consistent retina light levels provides excellent overall visibility while driving.

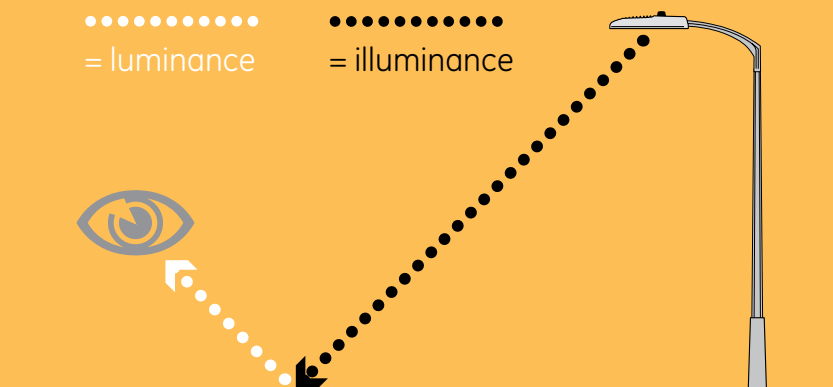



Optical design

Light on target: coefficient of utilization

By putting energy toward the task of lighting the roadway and not the surrounding area, Evolve ERL fixtures put light where it is intended and provide more efficient utilization of light. This is known as coefficient of utilization or (CU), and is a key characteristic of any fixture when determining its ability to light the intended area. A higher CU means less wasted light which, in turn, means lower energy consumption. This will reduce costs over the life of the fixture.

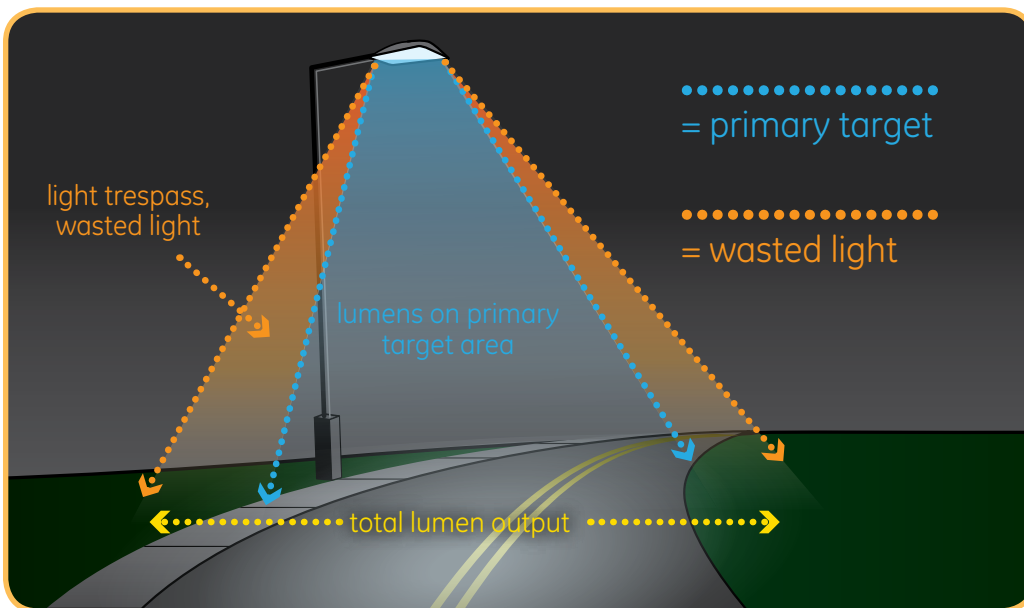

Efficiency in action

- Lumens per Watt (LPW) = Total Lumen Output/Total Watts
- Coefficient of Utilization (CU) = Lumens on Primary Target Area/Total Lumen Output
- Higher the Coefficient of Utilization (CU) = Less Wasted Light



Electrical design

Dependable drivers

Reliable GE Lightech drivers power Evolve ERL roadway fixtures. You can rest assured that the entire system, including driver, fixture and controls, is made, tested and warranted by the same manufacturer to ensure long term system reliability.

Surge protection

LED fixtures require robust surge protection devices to protect valuable components from voltage spikes and surge events over their operating life. Many surge protection devices are only rated for a single event. GE knows that a product's ability to survive repetitive events is key to maintenance-free operation.

GE's standard transient voltage surge suppression (TVSS) exceeds the U.S. DOE Municipalities Solid State Lighting Consortium (MSSLC) specification for surge protection devices. Evolve LED roadway fixtures come standard with a surge protection device verified to provide protection against at least 120 combination wave events of 6kV/3kA per IEEE/ANSI C62.41.2-2002. An optional high-capacity protection device that can survive up to 5,000 6kV/3kA events or 120 10kV/5kA (UL 1449) events is also available.

Surge hit tolerance comparison

	NUMBER OF STRIKES PROTECTED AGAINST
RATINGS OF MOST COMPETITOR OFFERINGS	1-30
GE STANDARD OFFERING (6kV/3kA)	120

FOR SITUATIONS REQUIRING PROTECTION AGAINST MORE POWERFUL STRIKES

GE OPTIONAL HIGH-CAPACITY OFFERING	5,000 6kV/5kA 120 10kV/5kA
------------------------------------	-------------------------------------



Mechanical design

Flexibility in design

GE offers a range of roadway lighting solutions to meet a wide variety of key customer requirements:

- Complete scalable lumen range
- Wide range of photometric selections
- Optimized wattage choices with drive current options
- Lumens per watt
- Luminaire feature content
- Surge suppression options

Fixtures that stand the test of time

Advanced engineering at its best, Evolve ERL & ERHM balances the technical needs of a sophisticated LED system with the functional demands of an outdoor fixture facing the year-round hazards of Mother Nature. The Evolve ERL & ERHM has a broad operating temperature range of -40°C to $+50^{\circ}\text{C}$, going above and beyond most standard fixture ratings to withstand potential extreme conditions.

The surface is protected by corrosion-resistant polyester powder paint applied at a minimum thickness of 2.0 mil to accommodate the long life of the fixture.





Sometimes, flat is better

Those crevices, pockets and ridges in competitor outdoor luminaires can become the perfect places for dirt and grime to collect—potentially reducing overall LED light output and impairing the intended pattern of light distribution. This problem is called Luminaire Dirt Depreciation (LDD) and it can reduce the performance of your outdoor LED lighting.

The Evolve fixture houses the LEDs and reflectors in a dirt- and dust-free cavity with an IP65/IP66-rated optical enclosure and a tempered glass lens to minimize the effects of dirt. This design approach provides consistent brightness and light distribution over the life of the product.



GE

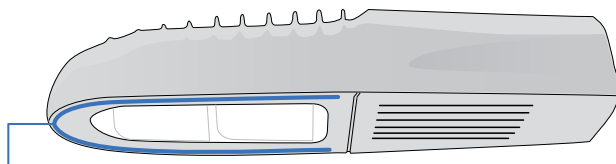

Flat, tempered glass lens protects the LED optical enclosure. Lens surface is smooth and flat which is less prone to dirt accumulation.

COMPETITION

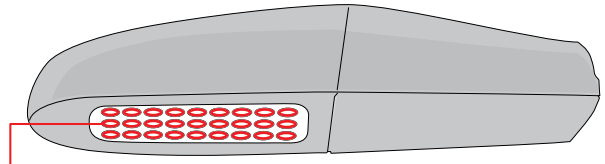

Designs that have exposed refractive optics have more crevices (or surfaces, edges, pockets) prone to dirt accumulation that could adversely affect the beam distribution pattern.

A recent Illuminating Engineering Society report* on LDD stated:

“LED luminaires with flat glass optics were less susceptible to average dirt depreciation than luminaires with exposed inner optics...With exposed optics, especially the individually molded acrylic, the surface of the optic is much more complex, has significantly more leeward edges, and significantly more surface area. These features will cause much more turbulence over the exposed optics, enabling dirt to accumulate on each individual optic and likely leading to more dirt sticking.”

*Source: Illuminating Engineering Society, RES-1-16 Measure and Report Luminaire Dirt Depreciation (LDD) in LED Luminaires for Street and Roadway Lighting Applications; page 71, Gibbons, Palmer, Meyer, Terry



Reliability & performance

Tried and true

Impressive long-life technology makes LED systems a long-term investment. Lasting significantly longer than traditional lighting sources, LED systems offer tremendous energy and maintenance savings that easily justify their higher upfront cost. But not all LED systems perform equally over their years of operation.

Inferior quality products can prematurely fail or degrade in light output far below initial claims — which results in failure to provide the value originally promised. At GE, our product life ratings recognize acceptable light levels for any given application to ensure you won't be left in the dark.



1 million+
unit hours



16,000+
hours at



+60°C
ambient

Rather than rely solely on test data from LED suppliers, we extensively test the complete system, using both in-house and independent labs around the world to validate performance. GE has accumulated more than 1 million unit hours of testing and more than 16,000 hours of testing at +60°C ambient, going beyond the industry's standard level of testing to ensure our fixtures can live up to our claims.

At GE, we know our fixtures can stand the test of time because we've designed them that way. It is this diligent approach to quality assurance that has earned GE a reputation as one of the most respected names in the industry.





Control capability

You're in control

While some might be satisfied with winning awards and industry recognition, we've never stopped to rest on those laurels. Instead, our team went the extra mile to bring you a whole new level of flexibility, efficiency and control.

Evolve ERL & ERHM fixtures are available with both wireless and non wireless stand alone control capability. The control module connection is made externally through an optional dimming control receptacle, making Evolve fixtures adaptive control ready.

Compatible for use with control options ranging from a simple shorting cap to a standard PE photocell control or sophisticated **GE LightGrid Outdoor Wireless Control System**, this solution allows for easy upgrading to other control solutions down the road, without any additional internal electrical components required.



STANDARD
SHORTING CAP



STANDARD PE
PHOTO CONTROL



GE LIGHTGRID
OUTDOOR WIRELESS
CONTROL SYSTEM



ANSI dimming receptacle will accept any standard PE or GE LightGrid Outdoor Wireless Control System.



Intelligent design

It all starts with the LightGrid node.

LightGrid™ Outdoor Wireless Control System The Right Light at the Right Time

LightGrid™ is a groundbreaking outdoor wireless control system for street and roadway lights. Honored with the 2015 Gold Edison Award for Outstanding Energy Management and Conservation, the unique technology inside this system allows for remote operation and monitoring of all fixtures through a Web-enabled central management system.

Designed with municipalities and transportation departments in mind, LightGrid offers many features, including:

- Accurate, utility-grade energy metering per pole you pay for what is used
- GPS chip embedded into node always know the exact location of controllers and fixtures; node automatically connects to the network and acquires location in just minutes, reducing commissioning time.
- One-piece control no special electronics necessary in the fixture; node simply connects to external socket, so it can be added easily at any time
- Operates with programmed schedules in case of network outage

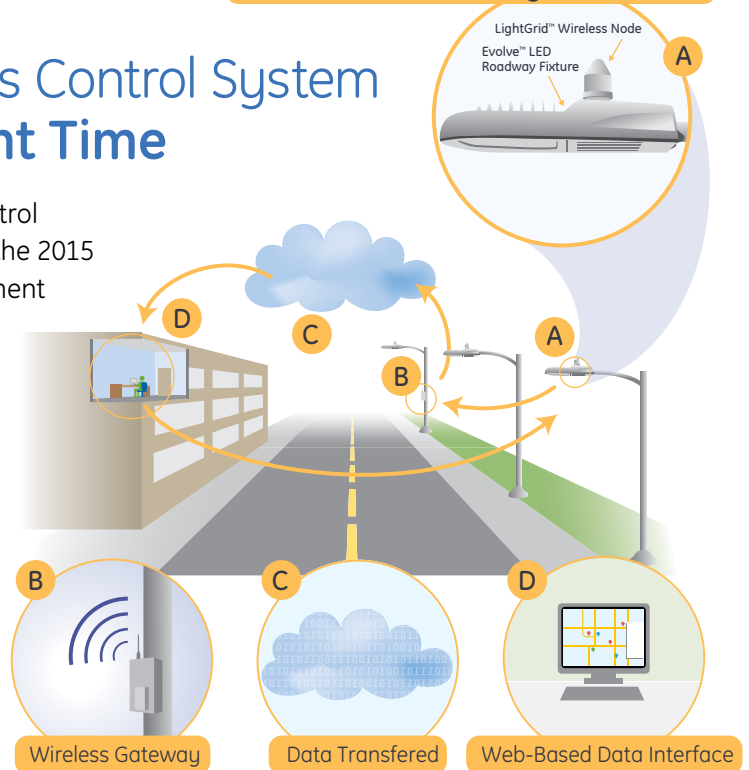

Let there be light. How much is up to you.

Control more with GE's LightGrid right from where you sit, and control costs every step of the way.



Control Metering



Control Maintenance



Control Output

Together with award-winning Evolve™ LED roadway lighting fixtures, LightGrid will deliver the energy efficiency, reliability and flexibility needed to optimize street and roadway lighting.



The **LightGrid™** system is made up of three basic components:

LightGrid nodes

- Built-in GPS device lets you know the exact location of each fixture, which provides confirmation of installation, as well as making for more efficient maintenance
- Automatically connects to the network, reducing commissioning time
- Utility-grade metering means you pay for actual energy use, with measurement accuracy of up to $\pm 0.5\%$
- One-piece control ensures no special electronics are needed, as node connects to external socket

LightGrid gateways

Each LightGrid wireless gateway can control a mesh network made up of 500+ nodes. Protected by an IP66 enclosure, they're designed for reliable operation, even in the harshest environments.

- Automated GPS detection
- 500m line-of-sight range
- Output: Standard TCP-IP interface
- Input: 120-277VAC

LightGrid server

With LightGrid, lighting data for every fixture is accessible through a Web-based interface that can be hosted remotely. Protected by a high level of security encryption, our central management server offers secure login for all users.

Armed with actionable information, municipalities and transportation departments can implement smarter energy-saving strategies through more precise on/off and dimming schedules, particularly during a middle-of-the-night operation in low-traffic areas. Other features include the ability to:

- Update easily with "over-the-air" firmware upgrades
- Send automated fault email notifications when something happens to a fixture
- Display GPS coordinates in the Google Maps format
- Present real-time lighting information with a single click
- Access scheduling, customized reporting, grouping and user access level management
- Dim manually with detailed information



GE Evolve™

LED Roadway Luminaire

ERL Series — with **Next Generation Optics**



The **Evolve™** LED Roadway Luminaire is optimized for customers requiring a LED solution for local, collector and major roadways. GE's unique reflective optics are designed to optimize application efficiency and minimize glare. The modern design incorporates the heat sink directly into the unit for heat transfer to prolong LED life. This reliable unit has a 100,000 hour design life, significantly reducing maintenance needs and expense over the life of the fixture. This efficient solution lowers energy consumption compared to traditional HID fixture for additional operating cost savings.

Features:

- Lumen output ranging from 1,900 to 30,000lm
- Photometric Options: Type II Narrow, Type II Wide, Type III, Type IV
- Evolve™ light engine consisting of reflective technology designed to optimize application efficiency and minimize glare
- 70 CRI at 3000K and 4000K typical
- -40° to 50°C UL Ambient Typical
- Coastal Finish Available
- International Dark-Sky Association (IDA) compliant

Applications:

- Local Roadways
- Collector Roadways
- Major Roadway/Streets



Previous Generation Optics vs. Next Generation Optics



GE Evolve™

LED Roadway High Mast Luminaire ERHM Series



The **Evolve™** LED High Mast is optimized for customers requiring a LED solution for expressway, freeway interchanges and other large area applications. GE's unique reflective optics are designed to optimize application efficiency and minimize glare. This reliable unit has a 100,000-hour design life, significantly reducing maintenance needs and expense over the life of the fixture. The ERHM luminaire is an efficient solution lowering energy consumption as compared to traditional HID fixtures providing additional operating cost savings.

Features:

- Lumen output ranging from 28,800 to 58,300 lm
- Photometric Options: Type II Narrow, Type II Wide, Type III, Type IV
- 70 CRI at 3000K and 4000K typical
- Field rotatable optics
- -40° to 50°C UL Ambient Typical
- Coastal Finish Available
- Designed & Assembled in USA

Applications:

- Airport Lighting,
- Expressway and Freeway Interchanges
- Port Facilities
- Trailer/Container Yard and Rail Yard Operations





Total solution



The GE Advantage™

- ① **Discovery & Design**
Before we illuminate, we listen. By understanding your goals and the makeup of your existing infrastructure, we can optimize a design that will meet codes, legislation and your objectives.
- ② **Innovative Systems**
Our unique reflective technology and broad product portfolio mean the best possible lighting solutions.
- ③ **Seamless Distribution**
Our recently re-imagined manufacturing facility and local support networks ensure products are available and on time.
- ④ **Integration Services**
Whether it's new construction or an update of existing infrastructure, our network of partners provide turnkey installation solutions.
- ⑤ **ROI Optimization**
We'll help you see financial benefits – as soon as the first month – through energy savings, utility rebate capture programs and financing options.



current
powered by GE

All trademarks are the property of their respective owners. Information provided is subject to change without notice. All values are design or typical values when measured under laboratory conditions. Current, powered by GE is a business of the General Electric Company.
© 2018 GE.





GE Evolve[®]

LED Roadway Lighting

ERL1-ERLH-ERL2



current
powered by GE



GE Evolve® LED Roadway Lighting ERL1-ERLH-ERL2



The **Evolve®** LED Roadway Luminaire is optimized for customers requiring a LED solution for local, collector and major roadways. GE's unique reflective optics are designed to optimize application efficiency and minimize glare. The modern design incorporates the heat sink directly into the unit for heat transfer to prolong LED life. This reliable unit has a 100,000 hour design life, significantly reducing maintenance needs and expense over the life of the fixture. This efficient solution lowers energy consumption compared to a traditional HID fixture for additional operating cost savings.

Features:

- Optimized roadway photometric distributions
- **Evolve®** light engine consisting of reflective technology designed to optimize application efficiency and minimize glare
- 70 CRI at 2700K, 3000K and 4000K typical.
- -40°C to 50°C UL Ambient Typical.
- ULOR = 0 (zero uplight)
- Designed & Assembled in USA

Applications:

- Local Roadways
- Collector Roadways
- Major Roadway/Streets



Compatible with **LightGrid** Outdoor Wireless Control System



To learn more about **GE Evolve® LED Roadway Lighting**, go to: www.currentbyge.com

GE Evolve®

LED Roadway Lighting

ERL1-ERLH-ERL2



Project name _____

Date _____

Type _____

Typical Specifications: ERL1-ERLH-ERL2

LED & Optical

- **Output Range:** 1900 – 30000 lm
- **Photometric Options:** Type II Narrow, Type II Wide, Type III, Type IV
- **System Efficacy:** 100 - 145 LPW
- **CCT:** 2700K, 3000K, 4000K; LEDs @ 70 CRI

Lumen Maintenance Tables

Projected Lxx per IES TM-21 at 25°C for reference:

ERL1 LUMEN OUTPUT CODES	LXX(10K)@HOURS		
	25,000 HR	50,000 HR	60,000 HR
02,03,04,05,06	L96	L95	L94
07,08,09	L95	L91	L89
10	L89	L80	L76

ERLH LUMEN OUTPUT CODES	LXX(10K)@HOURS		
	25,000 HR	50,000 HR	60,000 HR
10, 11	L97	L96	L96
13, 14	L95	L93	L92
15, 16	L94	L91	L91

ERL2 LUMEN OUTPUT CODES	LXX(10K)@HOURS		
	25,000 HR	50,000 HR	60,000 HR
16, 18, 19, 21, 23	L96	L94	L95
25, 27, 28	L95	L93	L92
30	L94	L91	L90

Note: Projected Lxx based on LM80 (10,000 hour testing). Accepted industry tolerances apply to initial luminous flux and lumen maintenance measurements.

Electrical

- **Input Voltage:** 120-277 volt and 347-480 volt
- **Input Frequency:** 50/60Hz
- **Power Factor (PF)*:** >90%
- **Total Harmonic Distortion (THD)*:** <20%

*Power factor and THD tolerance exceptions: ERL1 "02" Lumen output: PF and THD within tolerances above only at 120 volt. ERL1 "03" Lumen output: @120 volt PF~0.89; @ 480 volt THD~26% ERL1 "04" Lumen output: @480 volt THD~22%

Ratings

- **Surge Protection:** per ANSI C136.2-2015: (Driver Internal):
 - 6kV/3kA "Basic: (120 Strikes)" - Standard on ERL1 (02-06)
 - 10kV/5kA "Enhanced: (40 Strikes)" - Standard on ERL1 (07 - 10), ERLH, ERL2
- **(Additional Separate Secondary SPD)**
 - 10kV/5kA "Enhanced: (40 Strikes)" - Option "R"
 - 20kV/10kA "Elevated" (40 Strikes) - Option "T"
- **Safety:** UL/cUL Listed. UL 1598 listed, suitable for wet locations (UL) (UL)
- **Environmental:** Compliant with the materials restrictions of RoHS
- **EMI:** Title 47 CFR Part 15 Class A
- **Vibration:** 3G per ANSI C136.31-2010
- LM-79 testing in accordance with IESNA Standards
- Std. Optical enclosure rated per ANSI C136.25-2009:
 - ERL1/ERLH/ERL2 = IP65, Optional: IP66

Operating Temperature:

PRODUCT ID	LUMEN OUTPUT	AMBIENT READING
ERL1	02-10	-40°C to 50°C
ERLH	10-11, 13	-40°C to 50°C
ERLH	14-16	-40°C to 45°C
ERL2	16-28	-40°C to 50°C
ERL2	30	-40°C to 45°C

Delayed start may be experienced < -35°C

Construction & Finish

- **Housing:**
 - Die Cast Enclosure
 - Casting-integral heat sink for maximum heat transfer
- **Lensing:** Impact resistant tempered glass, standard
- **Paint:** Corrosion resistant polyester powder painted, minimum 2.0 mil. thickness.
 - Standard Colors: Dark Bronze, Black, & Gray
 - RAL & custom colors available
 - Optional coastal finish available.
- **Weight:** 12.4lbs (5.6kg) – 24lbs (10.9kg)

Warranty

- **System Warranty:** 5 Year Standard, 10 Year Optional

Controls

- **Dimming:**
 - Standard: 0-10V; Optional: DALI (120-277V Only)
- **Sensors:**
 - Photo electric sensors (PE) available.
- LightGrid™ compatible

Mounting

- Slipfitter with +/- 5 degree of adjustment for leveling.
- Integral die cast mounting pipe stop.
- Adjustable for 1.25 in. or 2 in. mounting pipe.

Suggested HID Replacement Lumen Levels

- ~4,000–5,000 lumens to replace 100W HPS Cobra-head
- ~7,000–8,800 lumens to replace 150W HPS Cobra-head
- ~8,500–11,500 lumens to replace 200W HPS Cobra-head
- ~11,500–14,000 lumens to replace 250W HPS Cobra-head
- ~21,000–30,000 lumens to replace 400W HPS Cobra-head

Note: Actual replacement lumens may vary based upon mounting height, pole spacing, design criteria, etc.

PREVIOUS	DESCRIPTION	CURRENT	DESCRIPTION
A1, B1	Extra Narrow/Narrow Asymmetric	A3	Type II Narrow
C1, E1	Asymmetric Short/Medium	B3	Type II Wide
D1, G1	Asymmetric Forward/Extra Wide	C3	Type III
F1	Asymmetric Wide	D3	Type IV
		E3	Type II Enhanced Back Light

**The information above is designed to provide a guideline to select the correct luminaire for a roadway application. The best and most accurate way to ensure the proper design is to do a lighting layout Utilizing AGI.



International Dark Sky Association listed. 2700K or 3000K must be selected to meet IDA certification and approval.

GE Evolve® LED Roadway Lighting

ERL1-ERLH-ERL2



Project name _____
Date _____
Type _____

ERL 1

PROD. ID	VOLTAGE	LUMEN OUTPUT	DISTRIBUTION*	CCT	CONTROLS	COLOR	OPTIONS
E = Evolve	0 = 120-277V*	02*	A3 = Type II Narrow	27 = 2700K <>	A = ANSI C136.41 7-pin	GRAY = Gray	A = 4 Bolt Slipfitter †
R = Roadway	1 = 120	03	B3 = Type II Wide	30 = 3000K <>	D = ANSI C136.41 7-pin with Shorting Cap	BLCK = Black	F = Fusing
L = Local	2 = 208	04	C3 = Type III	40 = 4000K	E = ANSI C136.41 7-pin with non-Dimming PE Control.*	DKBZ = Dark Bronze	G = Internal Bubble Level
1 = Single Module	3 = 240	05	D3 = Type IV	<> Select 2700K or 3000K CCT for IDA approved units.	*PE Control Only available for 120-277V or 480V Discrete. Not available for 347-480V or 347V Discrete.		I = IP66 Optical
	4 = 277	06	E3 = Type II Enhanced Back Light				L = Tool-Less Entry
	5 = 480	07	See Table				R = Secondary 10kV/5kA SPD
	D = 347	08	*Nominal IES Type classing subject to typical variation, individual units may differ.				T = Secondary 20kV/10kA SPD
	H = 347-480*#	09					U = DALI Programmable +^
	* Not available with Fusing. Must choose a discrete voltage with F option. # Not available with E controls option.	10					V1 = Variable Output via Field Adjustable Module**
							X = Single Package #
							Y = Coastal Finish*
							XXX = Special Options
							† Contact manufacturer for Lead-Time.
							# "X" option provides single pack box per fixture. Std Packaging = 20 units per Magna pak container.
							* Recommended for installations within 750 ft. from the coast. Contact Factory for Lead-Time.
							+ Compatible with LightGrid 2.0 nodes.
							^ Not available in 347V, 480V or 347-480V for Lumen Output Levels 07, 08, 09, and 10.
							** Not available with DALI (U) option.

LUMEN OUTPUT	DISTRIBUTION	TYPICAL INITIAL LUMENS			TYPICAL SYSTEM WATTAGE		BUG RATING			IES FILE NUMBER					
		4000K	3000K	2700K	120-277V	347-480V	4000K	3000K	2700K	4000K		3000K		2700K	
										120-277V	347-480V	120-277V	347-480V	120-277V	347-480V
02	A3	2000	1900	1900	14	N/A	B1-U0-G1	B1-U0-G1	B1-U0-G1	ERL1_02A340 -120VIES	N/A	ERL1_02A330 -120VIES	N/A	ERL1_02A327 -120VIES	N/A
	B3						B1-U0-G1	B1-U0-G1	B1-U0-G1	ERL1_02B340 -120VIES	N/A	ERL1_02B330 -120VIES	N/A	ERL1_02B327 -120VIES	N/A
	C3						B1-U0-G1	B1-U0-G1	B1-U0-G1	ERL1_02C340 -120VIES	N/A	ERL1_02C330 -120VIES	N/A	ERL1_02C327 -120VIES	N/A
	D3						B0-U0-G1	B0-U0-G1	B0-U0-G1	ERL1_02D340 -120VIES	N/A	ERL1_02D330 -120VIES	N/A	ERL1_02D327 -120VIES	N/A
	E3						B1-U0-G1	B1-U0-G1	B1-U0-G1	ERL1_02E340 -120VIES	N/A	ERL1_02E330 -120VIES	N/A	ERL1_02E327 -120VIES	N/A
03	A3	3000	2900	2800	22	26	B1-U0-G1	B1-U0-G1	B1-U0-G1	ERL1_03A340 -120-277VIES	ERL1_03A340 -347-480VIES	ERL1_03A330 -120-277VIES	ERL1_03A330 -347-480VIES	ERL1_03A327 -120-277VIES	ERL1_03A327 -347-480VIES
	B3						B1-U0-G1	B1-U0-G1	B1-U0-G1	ERL1_03B340 -120-277VIES	ERL1_03B340 -347-480VIES	ERL1_03B330 -120-277VIES	ERL1_03B330 -347-480VIES	ERL1_03B327 -120-277VIES	ERL1_03B327 -347-480VIES
	C3						B1-U0-G1	B1-U0-G1	B1-U0-G1	ERL1_03C340 -120-277VIES	ERL1_03C340 -347-480VIES	ERL1_03C330 -120-277VIES	ERL1_03C330 -347-480VIES	ERL1_03C327 -120-277VIES	ERL1_03C327 -347-480VIES
	D3						B1-U0-G1	B1-U0-G1	B1-U0-G1	ERL1_03D340 -120-277VIES	ERL1_03D340 -347-480VIES	ERL1_03D330 -120-277VIES	ERL1_03D330 -347-480VIES	ERL1_03D327 -120-277VIES	ERL1_03D327 -347-480VIES
	E3						B1-U0-G1	B1-U0-G1	B1-U0-G1	ERL1_03E340 -120-277VIES	ERL1_03E340 -347-480VIES	ERL1_03E330 -120-277VIES	ERL1_03E330 -347-480VIES	ERL1_03E327 -120-277VIES	ERL1_03E327 -347-480VIES
04	A3	4000	3900	3800	31	34	B1-U0-G1	B1-U0-G1	B1-U0-G1	ERL1_04A340 -120-277VIES	ERL1_04A340 -347-480VIES	ERL1_04A330 -120-277VIES	ERL1_04A330 -347-480VIES	ERL1_04A327 -120-277VIES	ERL1_04A327 -347-480VIES
	B3						B1-U0-G1	B1-U0-G1	B1-U0-G1	ERL1_04B340 -120-277VIES	ERL1_04B340 -347-480VIES	ERL1_04B330 -120-277VIES	ERL1_04B330 -347-480VIES	ERL1_04B327 -120-277VIES	ERL1_04B327 -347-480VIES
	C3						B1-U0-G1	B1-U0-G1	B1-U0-G1	ERL1_04C340 -120-277VIES	ERL1_04C340 -347-480VIES	ERL1_04C330 -120-277VIES	ERL1_04C330 -347-480VIES	ERL1_04C327 -120-277VIES	ERL1_04C327 -347-480VIES
	D3						B1-U0-G1	B1-U0-G1	B1-U0-G1	ERL1_04D340 -120-277VIES	ERL1_04D340 -347-480VIES	ERL1_04D330 -120-277VIES	ERL1_04D330 -347-480VIES	ERL1_04D327 -120-277VIES	ERL1_04D327 -347-480VIES
	E3						B1-U0-G1	B1-U0-G1	B1-U0-G1	ERL1_04E340 -120-277VIES	ERL1_04E340 -347-480VIES	ERL1_04E330 -120-277VIES	ERL1_04E330 -347-480VIES	ERL1_04E327 -120-277VIES	ERL1_04E327 -347-480VIES
05	A3	5000	4900	4700	39	43	B1-U0-G1	B1-U0-G1	B1-U0-G1	ERL1_05A340 -120-277VIES	ERL1_05A340 -347-480VIES	ERL1_05A330 -120-277VIES	ERL1_05A330 -347-480VIES	ERL1_05A327 -120-277VIES	ERL1_05A327 -347-480VIES
	B3						B1-U0-G1	B1-U0-G1	B1-U0-G1	ERL1_05B340 -120-277VIES	ERL1_05B340 -347-480VIES	ERL1_05B330 -120-277VIES	ERL1_05B330 -347-480VIES	ERL1_05B327 -120-277VIES	ERL1_05B327 -347-480VIES
	C3						B1-U0-G2	B1-U0-G2	B1-U0-G2	ERL1_05C340 -120-277VIES	ERL1_05C340 -347-480VIES	ERL1_05C330 -120-277VIES	ERL1_05C330 -347-480VIES	ERL1_05C327 -120-277VIES	ERL1_05C327 -347-480VIES
	D3						B1-U0-G1	B1-U0-G1	B1-U0-G1	ERL1_05D340 -120-277VIES	ERL1_05D340 -347-480VIES	ERL1_05D330 -120-277VIES	ERL1_05D330 -347-480VIES	ERL1_05D327 -120-277VIES	ERL1_05D327 -347-480VIES
	E3						B2-U0-G2	B1-U0-G1	B1-U0-G1	ERL1_05E340 -120-277VIES	ERL1_05E340 -347-480VIES	ERL1_05E330 -120-277VIES	ERL1_05E330 -347-480VIES	ERL1_05E327 -120-277VIES	ERL1_05E327 -347-480VIES
06	A3	6000	5800	5700	47	52	B2-U0-G2	B2-U0-G2	B2-U0-G2	ERL1_06A340 -120-277VIES	ERL1_06A340 -347-480VIES	ERL1_06A330 -120-277VIES	ERL1_06A330 -347-480VIES	ERL1_06A327 -120-277VIES	ERL1_06A327 -347-480VIES
	B3						B1-U0-G2	B1-U0-G2	B1-U0-G2	ERL1_06B340 -120-277VIES	ERL1_06B340 -347-480VIES	ERL1_06B330 -120-277VIES	ERL1_06B330 -347-480VIES	ERL1_06B327 -120-277VIES	ERL1_06B327 -347-480VIES
	C3						B1-U0-G2	B1-U0-G2	B1-U0-G2	ERL1_06C340 -120-277VIES	ERL1_06C340 -347-480VIES	ERL1_06C330 -120-277VIES	ERL1_06C330 -347-480VIES	ERL1_06C327 -120-277VIES	ERL1_06C327 -347-480VIES
	D3						B1-U0-G2	B1-U0-G2	B1-U0-G2	ERL1_06D340 -120-277VIES	ERL1_06D340 -347-480VIES	ERL1_06D330 -120-277VIES	ERL1_06D330 -347-480VIES	ERL1_06D327 -120-277VIES	ERL1_06D327 -347-480VIES
	E3						B2-U0-G2	B2-U0-G2	B2-U0-G2	ERL1_06E340 -120-277VIES	ERL1_06E340 -347-480VIES	ERL1_06E330 -120-277VIES	ERL1_06E330 -347-480VIES	ERL1_06E327 -120-277VIES	ERL1_06E327 -347-480VIES
07	A3	7000	6800	6600	58	B2-U0-G2	B2-U0-G2	B2-U0-G2	ERL1_07A340 .IES		ERL1_07A330 .IES		ERL1_07A327 .IES		
	B3					B1-U0-G2	B1-U0-G2	B1-U0-G2	ERL1_07B340 .IES		ERL1_07B330 .IES		ERL1_07B327 .IES		
	C3					B1-U0-G2	B1-U0-G2	B1-U0-G2	ERL1_07C340 .IES		ERL1_07C330 .IES		ERL1_07C327 .IES		
	D3					B1-U0-G2	B1-U0-G2	B1-U0-G2	ERL1_07D340 .IES		ERL1_07D330 .IES		ERL1_07D327 .IES		
	E3					B2-U0-G2	B2-U0-G2	B2-U0-G2	ERL1_07E340 .IES		ERL1_07E330 .IES		ERL1_07E327 .IES		
08	A3	8000	7800	7600	71	B2-U0-G2	B2-U0-G2	B2-U0-G2	ERL1_08A340 .IES		ERL1_08A330 .IES		ERL1_08A327 .IES		
	B3					B2-U0-G2	B2-U0-G2	B2-U0-G2	ERL1_08B340 .IES		ERL1_08B330 .IES		ERL1_08B327 .IES		
	C3					B1-U0-G2	B1-U0-G2	B1-U0-G2	ERL1_08C340 .IES		ERL1_08C330 .IES		ERL1_08C327 .IES		
	D3					B1-U0-G2	B1-U0-G2	B1-U0-G2	ERL1_08D340 .IES		ERL1_08D330 .IES		ERL1_08D327 .IES		
	E3					B2-U0-G2	B2-U0-G2	B2-U0-G2	ERL1_08E340 .IES		ERL1_08E330 .IES		ERL1_08E327 .IES		
09	A3	9000	8800	8500	84	B2-U0-G2	B2-U0-G2	B2-U0-G2	ERL1_09A340 .IES		ERL1_09A330 .IES		ERL1_09A327 .IES		
	B3					B2-U0-G2	B2-U0-G2	B2-U0-G2	ERL1_09B340 .IES		ERL1_09B330 .IES		ERL1_09B327 .IES		
	C3					B1-U0-G2	B1-U0-G2	B1-U0-G2	ERL1_09C340 .IES		ERL1_09C330 .IES		ERL1_09C327 .IES		
	D3					B1-U0-G2	B1-U0-G2	B1-U0-G2	ERL1_09D340 .IES		ERL1_09D330 .IES		ERL1_09D327 .IES		
	E3					B2-U0-G2	B2-U0-G2	B2-U0-G2	ERL1_09E340 .IES		ERL1_09E330 .IES		ERL1_09E327 .IES		
10	A3	9800	9600	9250	97	B2-U0-G2	B2-U0-G2	B2-U0-G2	ERL1_10A340 .IES		ERL1_10A330 .IES		ERL1_10A327 .IES		
	B3					B2-U0-G2	B2-U0-G2	B2-U0-G2	ERL1_10B340 .IES		ERL1_10B330 .IES		ERL1_10B327 .IES		
	C3					B2-U0-G2	B2-U0-G2	B2-U0-G2	ERL1_10C340 .IES		ERL1_10C330 .IES		ERL1_10C327 .IES		
	D3					B1-U0-G2	B1-U0-G2	B1-U0-G2	ERL1_10D340 .IES		ERL1_10D330 .IES		ERL1_10D327 .IES		
	E3					B2-U0-G2	B2-U0-G2	B2-U0-G2	ERL1_10E340 .IES		ERL1_10E330 .IES		ERL1_10E327 .IES		

Photometrics:

Evolve® LED Streetlight (ERL1)

ERL1

Type II Narrow
(05A340)

5,000 Lumens
4000K
ERL1_05A340____.IES

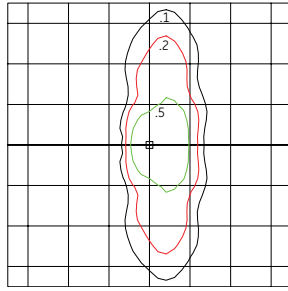

Grid Distance in Units of Mounting Height at 30'
Initial Footcandle Values at Grade

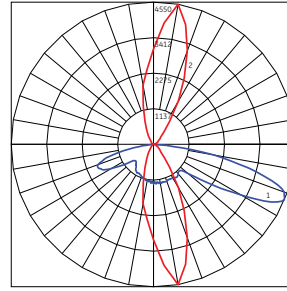

— Vertical plane through horizontal angle of Max. Cd at 80°
— Horizontal cone through vertical angle of Max. Cd at 67°

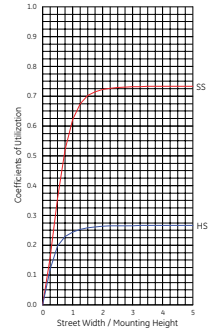

ERL1

Type II Wide
(05B340)

5,000 Lumens
4000K
ERL1_05B340____.IES

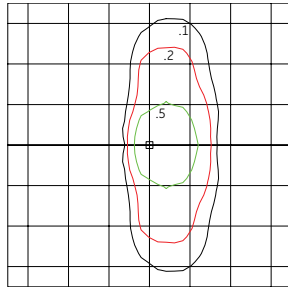

Grid Distance in Units of Mounting Height at 30'
Initial Footcandle Values at Grade

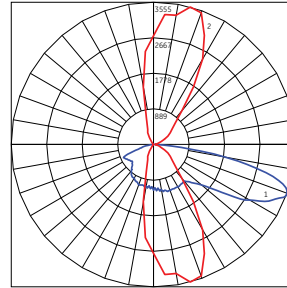

— Vertical plane through horizontal angle of Max. Cd at 75°
— Horizontal cone through vertical angle of Max. Cd at 69°

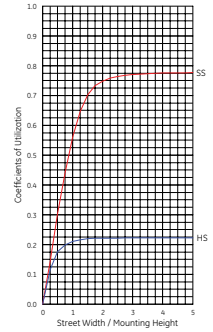

ERL1

Type III
(05C340)

5,000 Lumens
4000K
ERL1_05C340____.IES

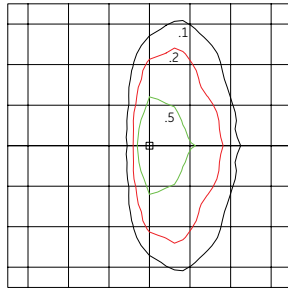

Grid Distance in Units of Mounting Height at 30'
Initial Footcandle Values at Grade

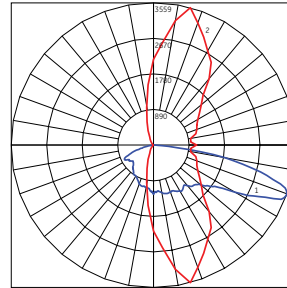

— Vertical plane through horizontal angle of Max. Cd at 75°
— Horizontal cone through vertical angle of Max. Cd at 70°

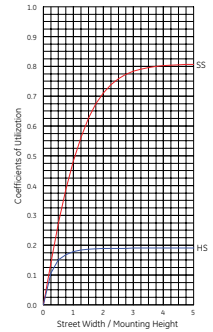

ERL1

Type IV
(05D340)

5,000 Lumens
4000K
ERL1_(05D340)____.IES

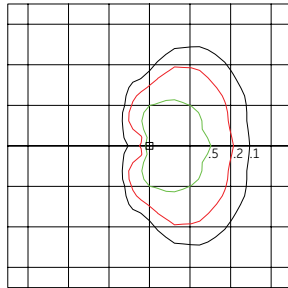

Grid Distance in Units of Mounting Height at 30'
Initial Footcandle Values at Grade

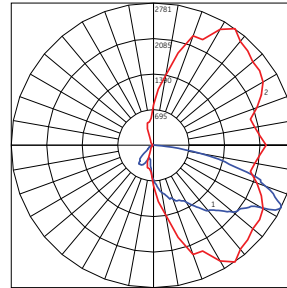

— Vertical plane through horizontal angle of Max. Cd at 55°
— Horizontal cone through vertical angle of Max. Cd at 64°

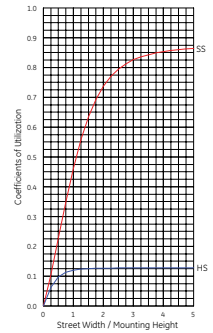

ERL1

Type II Enhanced Back Light
(05E340)

5,000 Lumens
4000K
ERL1_(05E340)____.IES

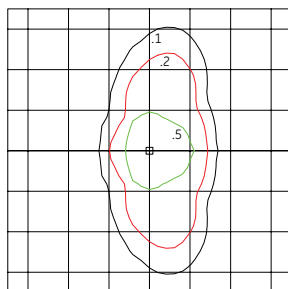

Grid Distance in Units of Mounting Height at 30'
Initial Footcandle Values at Grade

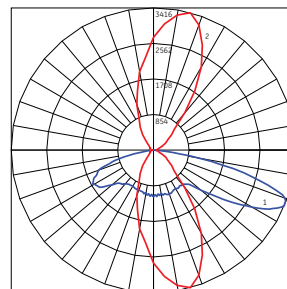

— Vertical plane through horizontal angle of Max. Cd at 75°
— Horizontal cone through vertical angle of Max. Cd at 67°

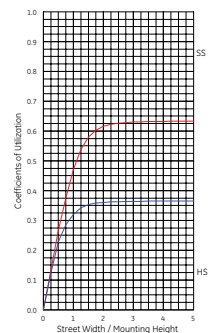

GE Evolve®

LED Roadway Lighting

ERL1-ERLH-ERL2



Project name _____

Date _____

Type _____

E R L H

PROD. ID	VOLTAGE	LUMEN OUTPUT	DISTRIBUTION*	CCT	CONTROLS	COLOR	OPTIONS
E = Evolve R = Roadway L = Local H = High Output	0 = 120-277V* 1 = 120 2 = 208 3 = 240 4 = 277 5 = 480 D = 347 H = 347-480*#	10 11 13 14 15 16 See Table	A3 = Type II Narrow B3 = Type II Wide C3 = Type III D3 = Type IV E3 = Type II Enhanced Back Light See Table *Nominal IES Type classing subject to typical variation, individual units may differ.	27 = 2700K<> 30 = 3000K<> 40 = 4000K <> Select 2700K or 3000K CCT for IDA approved units.	A = ANSI C136.41 7-pin D = ANSI C136.41 7-pin with Shorting Cap E = ANSI C136.41 7-pin with non-Dimming PE Control.* *PE Control Only available for 120-277V or 480V Discrete. Not available for 347-480V or 347V Discrete. NOTE: Dimming controls wired for 0-10V standard unless DALI option "U" requested.	GRAY = Gray BLCK = Black DKBZ = Dark Bronze	A = 4 Bolt Slipfitter † F = Fusing G = Internal Bubble Level I = IP66 Optical L = Tool-Less Entry R = Secondary 10kV/5kA SPD T = Secondary 20kV/10kA SPD U = DALI Programmable +^ V1 = Variable Output via Field Adjustable Module** X = Single Package # Y = Coastal Finish* XXX = Special Options † Contact manufacturer for Lead-Time. # "X" option provides single pack box per fixture. Std Packaging = 20 units per Magna pak container. * Recommended for installations within 750 ft. from the coast. Contact Factory for Lead-Time. + Compatible with LightGrid 2.0 nodes. ^ Not available in 347V, 480V or 347-480V. ** Not available with DALI (U) option.

LUMEN OUTPUT	DISTRIBUTION	TYPICAL INITIAL LUMENS			TYPICAL SYSTEM WATTAGE		BUG RATING			IES FILE NUMBER		
		4000K	3000K	2700K	120-277V	347-480V	4000K	3000K	2700K	4000K	3000K	2700K
10	A3	10000	9600	9300	82	B2-U0-G2	B2-U0-G2	B2-U0-G2	ERLH_10A340	ERLH_10A330	ERLH_10A327	
	B3					B2-U0-G2	B2-U0-G2	B2-U0-G2	ERLH_10B340	ERLH_10B330	ERLH_10B327	
	C3					B2-U0-G3	B2-U0-G3	B2-U0-G3	ERLH_10C340	ERLH_10C330	ERLH_10C327	
	D3					B1-U0-G3	B1-U0-G3	B1-U0-G3	ERLH_10D340	ERLH_10D330	ERLH_10D327	
	E3					B3-U0-G3	B3-U0-G3	B3-U0-G3	ERLH_10E340	ERLH_10E330	ERLH_10E327	
11	A3	11500	11000	10700	98	B3-U0-G3	B2-U0-G2	B2-U0-G2	ERLH_11A340	ERLH_11A330	ERLH_11A327	
	B3					B2-U0-G2	B2-U0-G2	B2-U0-G2	ERLH_11B340	ERLH_11B330	ERLH_11B327	
	C3					B2-U0-G3	B2-U0-G3	B2-U0-G3	ERLH_11C340	ERLH_11C330	ERLH_11C327	
	D3					B1-U0-G3	B1-U0-G2	B1-U0-G2	ERLH_11D340	ERLH_11D330	ERLH_11D327	
	E3					B3-U0-G3	B3-U0-G3	B3-U0-G3	ERLH_11E340	ERLH_11E330	ERLH_11E327	
13	A3	13000	12500	12100	111	B3-U0-G3	B3-U0-G3	B3-U0-G3	ERLH_13A340	ERLH_13A330	ERLH_13A327	
	B3					B2-U0-G3	B2-U0-G3	B2-U0-G3	ERLH_13B340	ERLH_13B330	ERLH_13B327	
	C3					B2-U0-G3	B2-U0-G3	B2-U0-G3	ERLH_13C340	ERLH_13C330	ERLH_13C327	
	D3					B2-U0-G3	B2-U0-G3	B1-U0-G3	ERLH_13D340	ERLH_13D330	ERLH_13D327	
	E3					B3-U0-G3	B3-U0-G3	B3-U0-G3	ERLH_13E340	ERLH_13E330	ERLH_13E327	
14	A3	14000	13400	13000	122	B3-U0-G3	B3-U0-G3	B3-U0-G3	ERLH_14A340	ERLH_14A330	ERLH_14A327	
	B3					B2-U0-G3	B2-U0-G3	B2-U0-G3	ERLH_14B340	ERLH_14B330	ERLH_14B327	
	C3					B2-U0-G3	B2-U0-G3	B2-U0-G3	ERLH_14C340	ERLH_14C330	ERLH_14C327	
	D3					B2-U0-G3	B2-U0-G3	B2-U0-G3	ERLH_14D340	ERLH_14D330	ERLH_14D327	
	E3					B3-U0-G3	B3-U0-G3	B3-U0-G3	ERLH_14E340	ERLH_14E330	ERLH_14E327	
15	A3	15000	14400	13900	136	B3-U0-G3	B3-U0-G3	B3-U0-G3	ERLH_15A340	ERLH_15A330	ERLH_15A327	
	B3					B2-U0-G3	B2-U0-G3	B2-U0-G3	ERLH_15B340	ERLH_15B330	ERLH_15B327	
	C3					B2-U0-G3	B2-U0-G3	B2-U0-G3	ERLH_15C340	ERLH_15C330	ERLH_15C327	
	D3					B2-U0-G3	B2-U0-G3	B2-U0-G3	ERLH_15D340	ERLH_15D330	ERLH_15D327	
	E3					B3-U0-G3	B3-U0-G3	B3-U0-G3	ERLH_15E340	ERLH_15E330	ERLH_15E327	
16	A3	16000	15300	14900	149	B3-U0-G3	B3-U0-G3	B3-U0-G3	ERLH_16A340	ERLH_16A330	ERLH_16A327	
	B3					B3-U0-G3	B2-U0-G3	B2-U0-G3	ERLH_16B340	ERLH_16B330	ERLH_16B327	
	C3					B2-U0-G3	B2-U0-G3	B2-U0-G3	ERLH_16C340	ERLH_16C330	ERLH_16C327	
	D3					B2-U0-G3	B2-U0-G3	B2-U0-G3	ERLH_16D340	ERLH_16D330	ERLH_16D327	
	E3					B3-U0-G3	B3-U0-G3	B3-U0-G3	ERLH_16E340	ERLH_16E330	ERLH_16E327	

Photometrics: Evolve® LED Streetlight (ERLH)

ERLH

Type II Narrow
(13A340)

13,000 Lumens
4000K
ERLH_13A340__IES

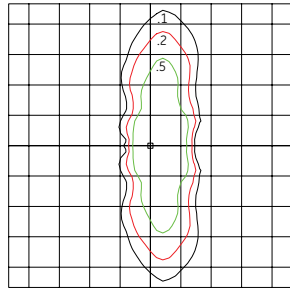

Grid Distance in Units of Mounting Height at 30'
Initial Footcandle Values at Grade

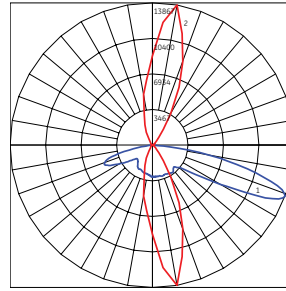

— Vertical plane through horizontal angle of Max. Cd at 80°
— Horizontal cone through vertical angle of Max. Cd at 69°

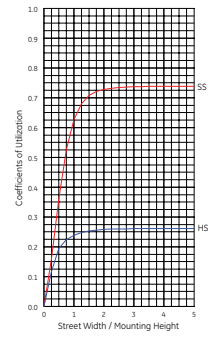

ERLH

Type II Wide
(13B340)

13,000 Lumens
4000K
ERLH_13B340__IES

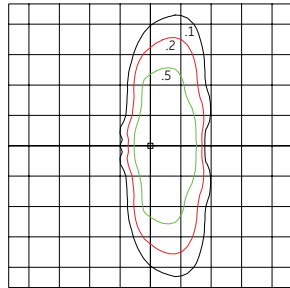

Grid Distance in Units of Mounting Height at 30'
Initial Footcandle Values at Grade

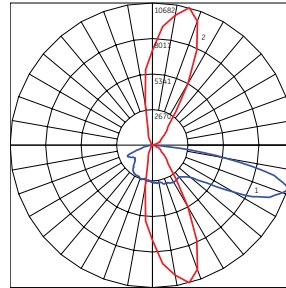

— Vertical plane through horizontal angle of Max. Cd at 75°
— Horizontal cone through vertical angle of Max. Cd at 72°

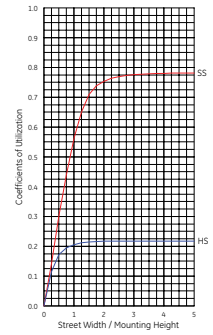

ERLH

Type III
(13C340)

13,000 Lumens
4000K
ERLH_13C340__IES

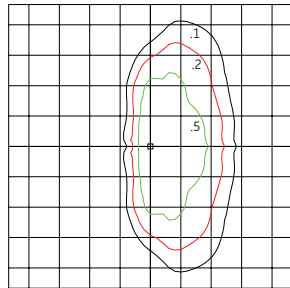

Grid Distance in Units of Mounting Height at 30'
Initial Footcandle Values at Grade

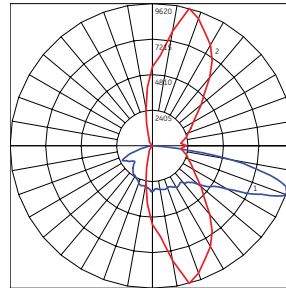

— Vertical plane through horizontal angle of Max. Cd at 75°
— Horizontal cone through vertical angle of Max. Cd at 71°

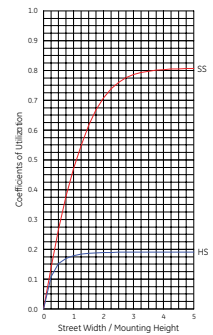

ERLH

Type IV
13D340

13,000 Lumens
4000K
ERLH_13D340__IES

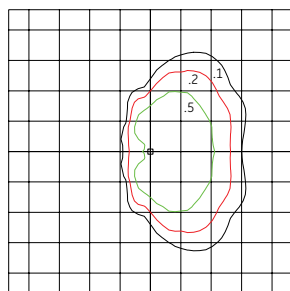

Grid Distance in Units of Mounting Height at 30'
Initial Footcandle Values at Grade

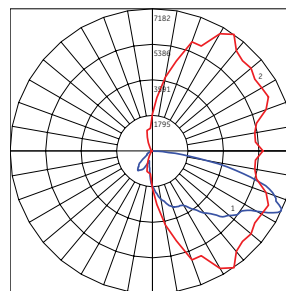

— Vertical plane through horizontal angle of Max. Cd at 55°
— Horizontal cone through vertical angle of Max. Cd at 65°

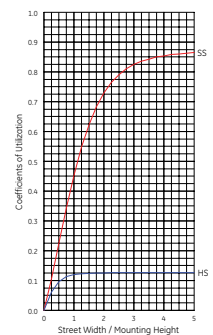

ERLH

Type II Enhanced Back Light
13E340

13,000 Lumens
4000K
ERLH_13E340__IES

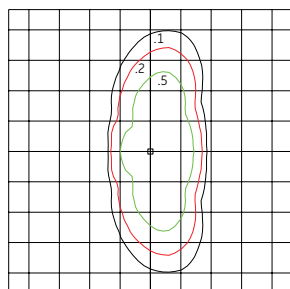

Grid Distance in Units of Mounting Height at 30'
Initial Footcandle Values at Grade

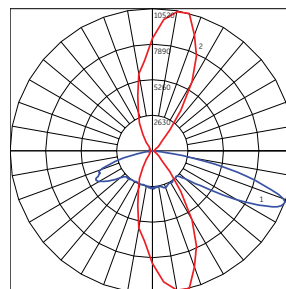

— Vertical plane through horizontal angle of Max. Cd at 75°
— Horizontal cone through vertical angle of Max. Cd at 69°

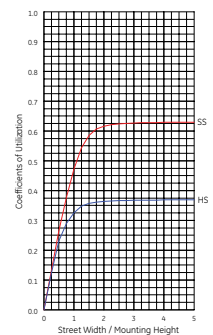



Project name _____

Date _____

Type _____

ERL2

PROD. ID	VOLTAGE	LUMEN OUTPUT	DISTRIBUTION*	CCT	CONTROLS	COLOR	OPTIONS
E = Evolve	0 = 120-277V*	16	A3 = Type II Narrow	27 = 2700K <>	A = ANSI C136.41 7-pin	GRAY = Gray	A = 4 Bolt Slipfitter †
R = Roadway	1 = 120	18	B3 = Type II Wide	30 = 3000K <>	D = ANSI C136.41 7-pin with Shorting Cap	BLK = Black	F = Fusing
L = Local	2 = 208	19	C3 = Type III	40 = 4000K	E = ANSI C136.41 7-pin with non-Dimming PE Control.*	DKBZ = Dark Bronze	G = Internal Bubble Level
2 = Double Module	3 = 240	21	D3 = Type IV	<> Select 2700K or 3000K CCT for IDA approved units.	*PE Control Only available for 120-277V or 480V Discrete. Not available for 347-480V or 347V Discrete.		I = IP66 Optical
	4 = 277	23	E3 = Type II Enhanced Back Light				L = Tool-Less Entry
	5 = 480	25	See Table				M1 = Magnapack***
	D = 347	27	*Nominal IES Type classing subject to typical variation, individual units may differ.				R = Secondary 10kV/5kA SPD
	H = 347-480*#	28					T = Secondary 20kV/10kA SPD
		30					U = DALI Programmable ^
	* Not available with Fusing. Must choose a discrete voltage with F option. # Not available with E controls option.	See Table					V1 = Variable Output via Field Adjustable Module**
							Y = Coastal Finish*
							XXX = Special Options

† Contact manufacturer for Lead-Time.
* Recommended for installations within 750 ft. from the coast. Contact Factory for Lead-Time.
+ Compatible with LightGrid 2.0 nodes.
^ Not available in 347V, 480V or 347-480V.
** Not available with DALI (U) option.
*** 20 fixtures per Magnapack.

LUMEN OUTPUT	DISTRIBUTION	TYPICAL INITIAL LUMENS			TYPICAL SYSTEM WATTAGE		BUG RATING			IES FILE NUMBER					
		4000K	3000K	2700K	120-277V	347-480V	4000K	3000K	2700K	4000K		3000K		2700K	
										120-277V	347-480V	120-277V	347-480V	120-277V	347-480V
16	A3	16000	15300	14900	120		B3-U0-G3	B3-U0-G3	B3-U0-G3	ERL2_16A340_IES		ERL2_16A330_IES		ERL2_16A327_IES	
	B3						B3-U0-G3	B3-U0-G3	B2-U0-G3	ERL2_16B340_IES		ERL2_16B330_IES		ERL2_16B327_IES	
	C3						B2-U0-G3	B2-U0-G3	B2-U0-G3	ERL2_16C340_IES		ERL2_16C330_IES		ERL2_16C327_IES	
	D3						B2-U0-G3	B2-U0-G3	B2-U0-G3	ERL2_16D340_IES		ERL2_16D330_IES		ERL2_16D327_IES	
	E3						B3-U0-G3	B3-U0-G3	B3-U0-G3	ERL2_16E340_IES		ERL2_16E330_IES		ERL2_16E327_IES	
18	A3	18000	17300	16700	140		B3-U0-G3	B3-U0-G3	B3-U0-G3	ERL2_18A340_IES		ERL2_18A330_IES		ERL2_18A327_IES	
	B3						B3-U0-G3	B3-U0-G3	B3-U0-G3	ERL2_18B340_IES		ERL2_18B330_IES		ERL2_18B327_IES	
	C3						B2-U0-G3	B2-U0-G3	B2-U0-G3	ERL2_18C340_IES		ERL2_18C330_IES		ERL2_18C327_IES	
	D3						B2-U0-G3	B2-U0-G3	B2-U0-G3	ERL2_18D340_IES		ERL2_18D330_IES		ERL2_18D327_IES	
	E3						B3-U0-G3	B3-U0-G3	B3-U0-G3	ERL2_18E340_IES		ERL2_18E330_IES		ERL2_18E327_IES	
19	A3	19000	18200	17700	149		B3-U0-G3	B3-U0-G3	B3-U0-G3	ERL2_19A340_IES		ERL2_19A330_IES		ERL2_19A327_IES	
	B3						B3-U0-G3	B3-U0-G3	B3-U0-G3	ERL2_19B340_IES		ERL2_19B330_IES		ERL2_19B327_IES	
	C3						B3-U0-G3	B2-U0-G3	B2-U0-G3	ERL2_19C340_IES		ERL2_19C330_IES		ERL2_19C327_IES	
	D3						B2-U0-G3	B2-U0-G3	B2-U0-G3	ERL2_19D340_IES		ERL2_19D330_IES		ERL2_19D327_IES	
	E3						B3-U0-G3	B3-U0-G3	B3-U0-G3	ERL2_19E340_IES		ERL2_19E330_IES		ERL2_19E327_IES	
21	A3	21000	20100	19500	174	177	B3-U0-G3	B3-U0-G3	B3-U0-G3	ERL2_21A340_-120-277VIES	ERL2_21A340_-347-480VIES	ERL2_21A330_-120-277VIES	ERL2_21A330_-347-480VIES	ERL2_21A327_-120-277VIES	ERL2_21A327_-347-480VIES
	B3						B3-U0-G3	B3-U0-G3	B3-U0-G3	ERL2_21B340_-120-277VIES	ERL2_21B340_-347-480VIES	ERL2_21B330_-120-277VIES	ERL2_21B330_-347-480VIES	ERL2_21B327_-120-277VIES	ERL2_21B327_-347-480VIES
	C3						B3-U0-G3	B3-U0-G3	B3-U0-G3	ERL2_21C340_-120-277VIES	ERL2_21C340_-347-480VIES	ERL2_21C330_-120-277VIES	ERL2_21C330_-347-480VIES	ERL2_21C327_-120-277VIES	ERL2_21C327_-347-480VIES
	D3						B2-U0-G3	B2-U0-G3	B2-U0-G3	ERL2_21D340_-120-277VIES	ERL2_21D340_-347-480VIES	ERL2_21D330_-120-277VIES	ERL2_21D330_-347-480VIES	ERL2_21D327_-120-277VIES	ERL2_21D327_-347-480VIES
	E3						B3-U0-G3	B3-U0-G3	B3-U0-G3	ERL2_21E340_-120-277VIES	ERL2_21E340_-347-480VIES	ERL2_21E330_-120-277VIES	ERL2_21E330_-347-480VIES	ERL2_21E327_-120-277VIES	ERL2_21E327_-347-480VIES
23	A3	23000	22100	21400	194	196	B3-U0-G3	B3-U0-G3	B3-U0-G3	ERL2_23A340_-120-277VIES	ERL2_23A340_-347-480VIES	ERL2_23A330_-120-277VIES	ERL2_23A330_-347-480VIES	ERL2_23A327_-120-277VIES	ERL2_23A327_-347-480VIES
	B3						B3-U0-G3	B3-U0-G3	B3-U0-G3	ERL2_23B340_-120-277VIES	ERL2_23B340_-347-480VIES	ERL2_23B330_-120-277VIES	ERL2_23B330_-347-480VIES	ERL2_23B327_-120-277VIES	ERL2_23B327_-347-480VIES
	C3						B3-U0-G4	B3-U0-G4	B3-U0-G4	ERL2_23C340_-120-277VIES	ERL2_23C340_-347-480VIES	ERL2_23C330_-120-277VIES	ERL2_23C330_-347-480VIES	ERL2_23C327_-120-277VIES	ERL2_23C327_-347-480VIES
	D3						B2-U0-G4	B2-U0-G4	B2-U0-G4	ERL2_23D340_-120-277VIES	ERL2_23D340_-347-480VIES	ERL2_23D330_-120-277VIES	ERL2_23D330_-347-480VIES	ERL2_23D327_-120-277VIES	ERL2_23D327_-347-480VIES
	E3						B3-U0-G3	B3-U0-G3	B3-U0-G3	ERL2_23E340_-120-277VIES	ERL2_23E340_-347-480VIES	ERL2_23E330_-120-277VIES	ERL2_23E330_-347-480VIES	ERL2_23E327_-120-277VIES	ERL2_23E327_-347-480VIES
25	A3	25000	24000	23300	214		B3-U0-G3	B3-U0-G3	B3-U0-G3	ERL2_25A340_IES		ERL2_25A330_IES		ERL2_25A327_IES	
	B3						B3-U0-G3	B3-U0-G3	B3-U0-G3	ERL2_25B340_IES		ERL2_25B330_IES		ERL2_25B327_IES	
	C3						B3-U0-G4	B3-U0-G4	B3-U0-G4	ERL2_25C340_IES		ERL2_25C330_IES		ERL2_25C327_IES	
	D3						B2-U0-G4	B2-U0-G4	B2-U0-G4	ERL2_25D340_IES		ERL2_25D330_IES		ERL2_25D327_IES	
	E3						B4-U0-G4	B4-U0-G4	B4-U0-G4	ERL2_25E340_IES		ERL2_25E330_IES		ERL2_25E327_IES	
27	A3	27000	25900	25100	237		B3-U0-G3	B3-U0-G3	B3-U0-G3	ERL2_27A340_IES		ERL2_27A330_IES		ERL2_27A327_IES	
	B3						B3-U0-G4	B3-U0-G4	B3-U0-G4	ERL2_27B340_IES		ERL2_27B330_IES		ERL2_27B327_IES	
	C3						B3-U0-G4	B3-U0-G4	B3-U0-G4	ERL2_27C340_IES		ERL2_27C330_IES		ERL2_27C327_IES	
	D3						B2-U0-G4	B2-U0-G4	B2-U0-G4	ERL2_27D340_IES		ERL2_27D330_IES		ERL2_27D327_IES	
	E3						B4-U0-G4	B4-U0-G4	B4-U0-G4	ERL2_27E340_IES		ERL2_27E330_IES		ERL2_27E327_IES	
28	A3	28000	26900	26100	251		B3-U0-G3	B3-U0-G3	B3-U0-G3	ERL2_28A340_IES		ERL2_28A330_IES		ERL2_28A327_IES	
	B3						B3-U0-G4	B3-U0-G4	B3-U0-G4	ERL2_28B340_IES		ERL2_28B330_IES		ERL2_28B327_IES	
	C3						B3-U0-G4	B3-U0-G4	B3-U0-G4	ERL2_28C340_IES		ERL2_28C330_IES		ERL2_28C327_IES	
	D3						B2-U0-G4	B2-U0-G4	B2-U0-G4	ERL2_28D340_IES		ERL2_28D330_IES		ERL2_28D327_IES	
	E3						B4-U0-G4	B4-U0-G4	B4-U0-G4	ERL2_28E340_IES		ERL2_28E330_IES		ERL2_28E327_IES	
30	A3	30000	28800	27900	278		B4-U0-G4	B4-U0-G4	B3-U0-G3	ERL2_30A340_IES		ERL2_30A330_IES		ERL2_30A327_IES	
	B3						B3-U0-G4	B3-U0-G4	B3-U0-G4	ERL2_30B340_IES		ERL2_30B330_IES		ERL2_30B327_IES	
	C3						B3-U0-G4	B3-U0-G4	B3-U0-G4	ERL2_30C340_IES		ERL2_30C330_IES		ERL2_30C327_IES	
	D3						B2-U0-G4	B2-U0-G4	B2-U0-G4	ERL2_30D340_IES		ERL2_30D330_IES		ERL2_30D327_IES	
	E3						B4-U0-G4	B4-U0-G4	B4-U0-G4	ERL2_30E340_IES		ERL2_30E330_IES		ERL2_30E327_IES	

Photometrics: Evolve® LED Streetlight (ERL2)

ERL2

Type II Narrow
(23A340)

23,000 Lumens
4000K
ERL2_23A340___.IES

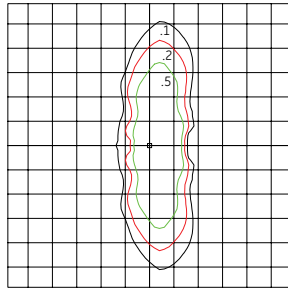

Grid Distance in Units of Mounting Height at 30'
Initial Footcandle Values at Grade

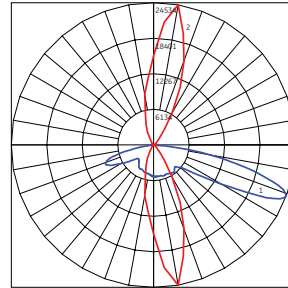

— Vertical plane through horizontal angle of Max. Cd at 80°
— Horizontal cone through vertical angle of Max. Cd at 69°

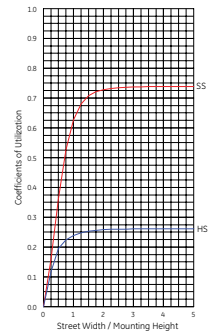

ERL2

Type II Wide
(23B340)

23,000 Lumens
4000K
ERL2_23B340___.IES

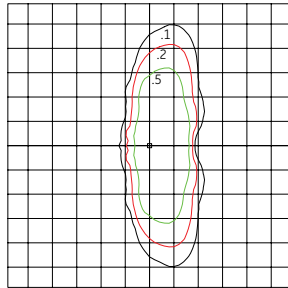

Grid Distance in Units of Mounting Height at 30'
Initial Footcandle Values at Grade

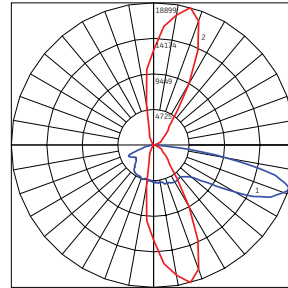

— Vertical plane through horizontal angle of Max. Cd at 75°
— Horizontal cone through vertical angle of Max. Cd at 72°

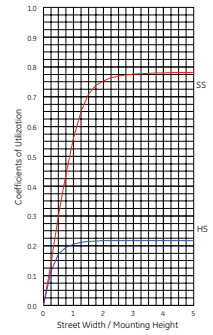

ERL2

Type III
(23C340)

23,000 Lumens
4000K
ERL2_23C340___.IES

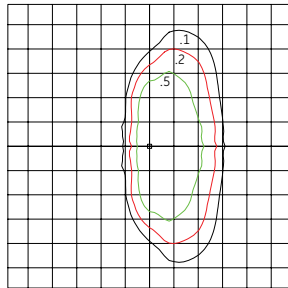

Grid Distance in Units of Mounting Height at 30'
Initial Footcandle Values at Grade

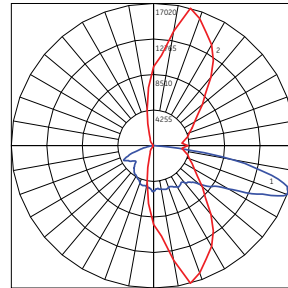

— Vertical plane through horizontal angle of Max. Cd at 75°
— Horizontal cone through vertical angle of Max. Cd at 71°

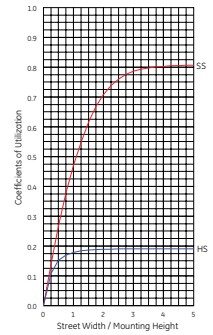

ERL2

Type IV
(23D340)

23,000 Lumens
4000K
ERL2_23D340___.IES

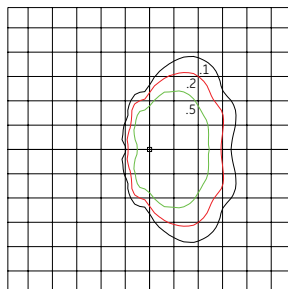

Grid Distance in Units of Mounting Height at 30'
Initial Footcandle Values at Grade

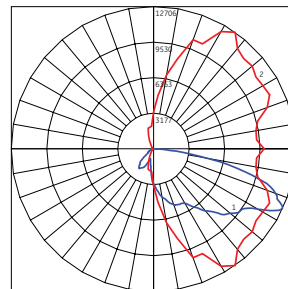

— Vertical plane through horizontal angle of Max. Cd at 55°
— Horizontal cone through vertical angle of Max. Cd at 65°

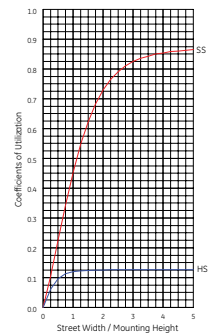

ERL2

Type II Enhanced Back Light
(23E340)

23,000 Lumens
4000K
ERL2_23E340___.IES

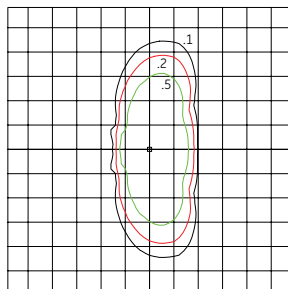

Grid Distance in Units of Mounting Height at 30'
Initial Footcandle Values at Grade

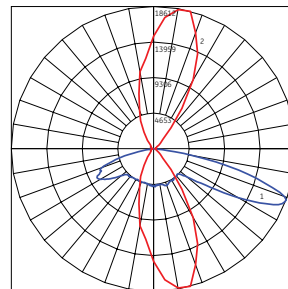

— Vertical plane through horizontal angle of Max. Cd at 75°
— Horizontal cone through vertical angle of Max. Cd at 69°

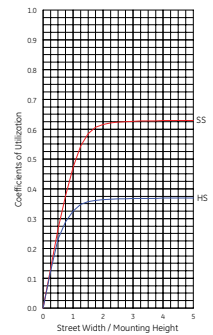

GE Evolve®
 LED Roadway Lighting
 ERL1-ERLH-ERL2

Product Dimensions:
 Evolve® LED Streetlight (ERL1)

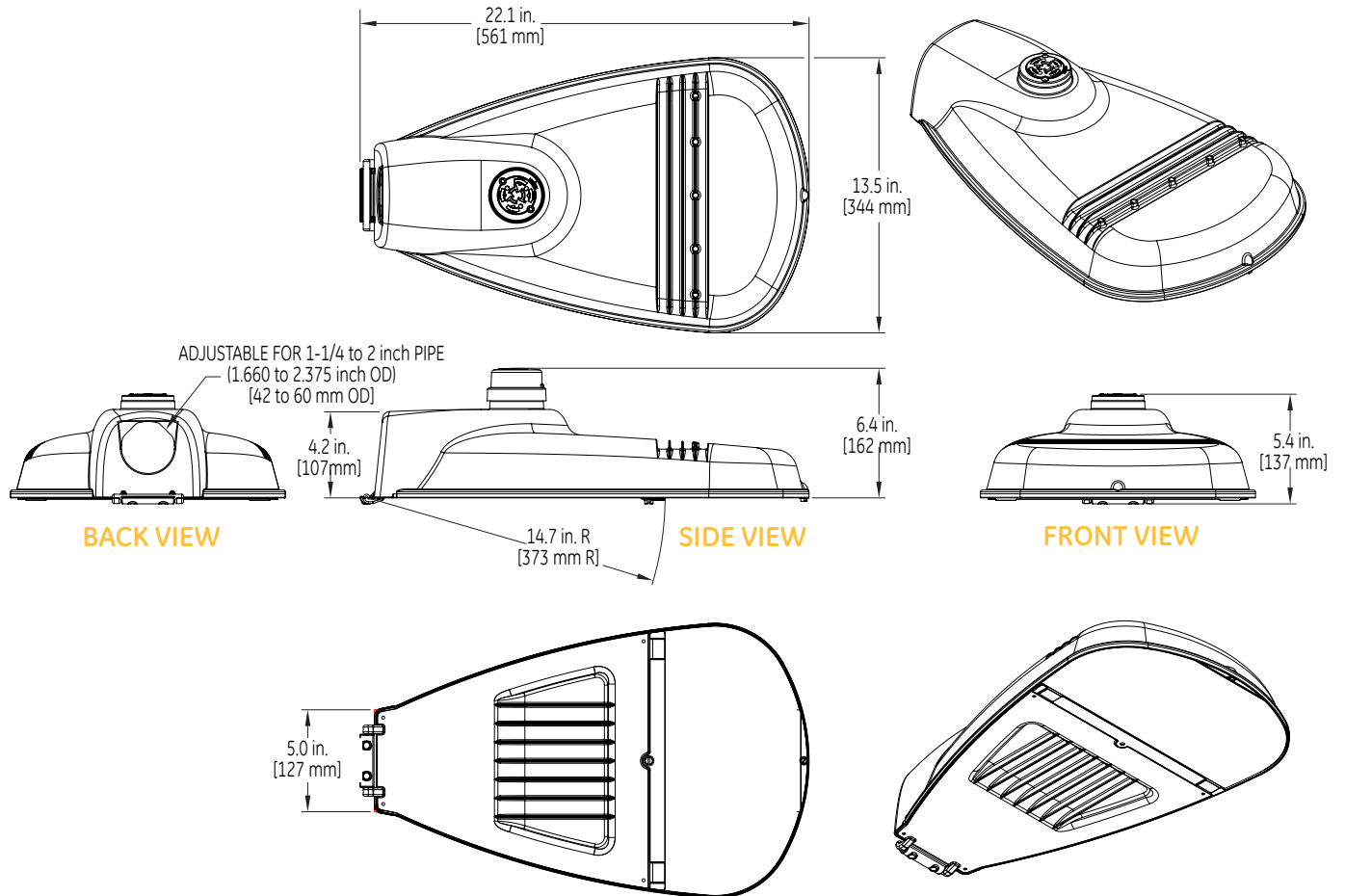

DATA

- Approximate net weight: 12.4 lbs (5.6kgs) -15.5 lbs (7.0kgs) with XFMR
- Effective Projected Area (EPA): 0.5 sq ft max (0.046 sq m)

GE Evolve®
 LED Roadway Lighting
 ERL1-ERLH-ERL2

Product Dimensions:
 Evolve® LED Streetlight (ERLH)

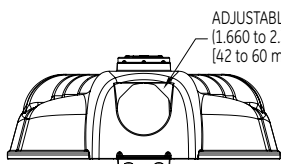
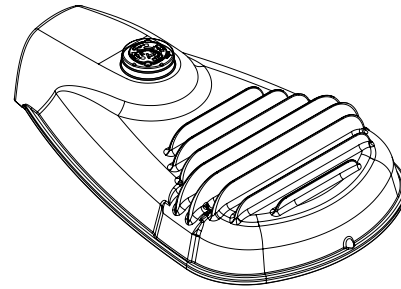
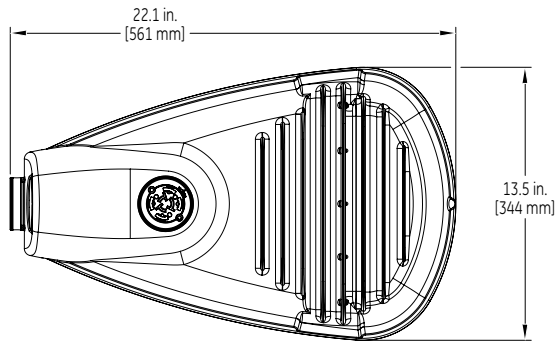

BACK VIEW

ADJUSTABLE FOR 1-1/4 to 2 inch PIPE
 (1.660 to 2.375 inch OD)
 (42 to 60 mm OD)

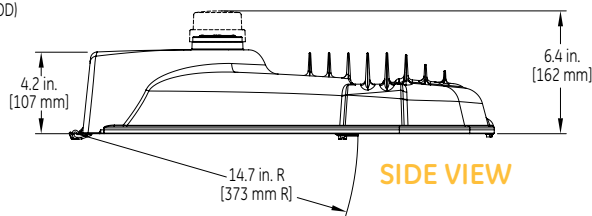

SIDE VIEW

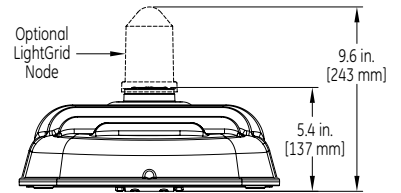

FRONT VIEW

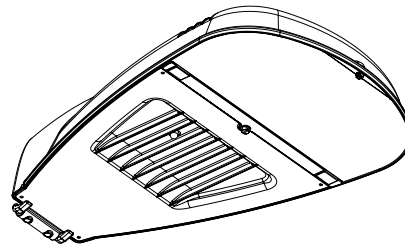
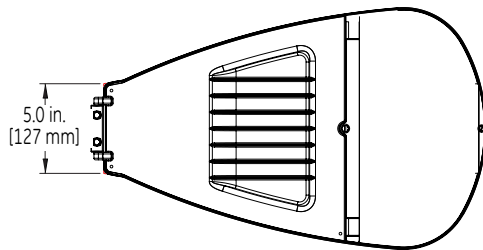

DATA

- Approximate net weight: 15.15 lbs (6.9 kgs) - 2 Bolt Slipfitter
- Approximate net weight: 15.85 lbs (7.2 kgs) - 4 Bolt Slipfitter
- Effective Projected Area (EPA): 0.5 sq ft max (0.046 sq m)

GE Evolve®
LED Roadway Lighting
 ERL1-ERLH-ERL2

Product Dimensions:
Evolve® LED Streetlight (ERL2)

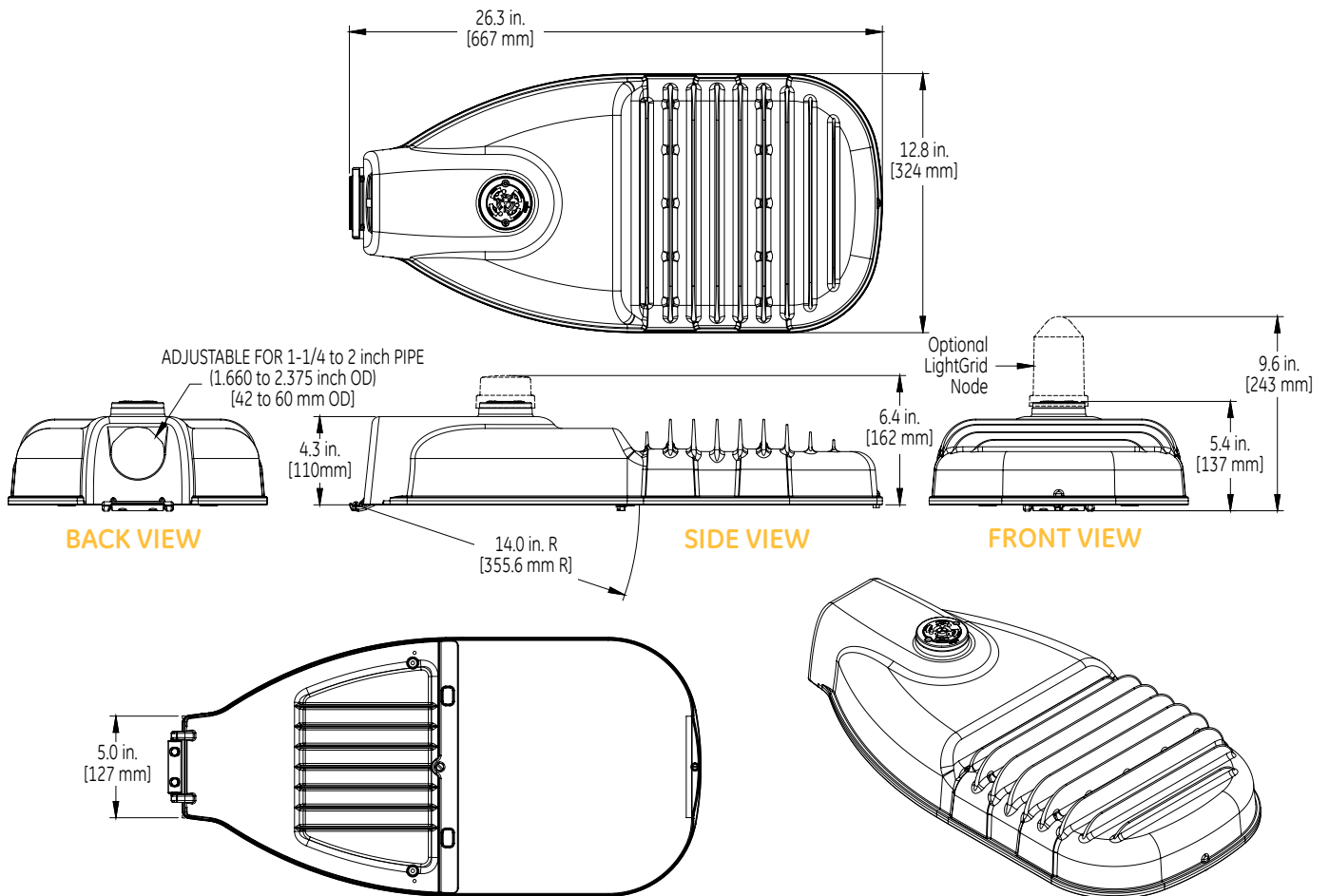

DATA

- Approximate net weight: 24.0 lbs (10.9 kgs)
 Contact manufacturer for specific configuration weight.
- Effective Projected Area (EPA): 0.57 sq ft max (0.053 sq m)





GE Evolve™

LED Roadway Lighting

ERLC

current
powered by GE



GE Evolve™ LED Roadway Lighting ERLC

The **Evolve** LED Roadway ERLC Luminaire is optimized for customers requiring a LED solution for local, collector and major roadways. GE's unique reflective optics are designed to optimize application efficiency and minimize glare. The modern design incorporates the heat sink directly into the unit for heat transfer to prolong LED life. This reliable unit has a 100,000 hour design life, significantly reducing maintenance needs and expense over the life of the fixture. This efficient solution lowers energy consumption compared to a traditional HID fixture for additional operating cost savings.

Features:

- Optimized roadway photometric distributions
- **Evolve** light engine consisting of reflective technology designed to optimize application efficiency and minimize glare
- Die-Cast aluminum housing
- Light weight: 8.5 lbs
- System LPW performance: 102-133 LPW
- 10Kv/5kA surge protection standard
- Tool-Less option

Applications:

- Local Roadways
- Collector Roadways
- Major Roadway/Streets



Compatible with **LightGrid™** Outdoor Wireless Control System



To learn more about **GE Evolve LED Roadway ERLC Lighting**, go to: www.currentbyge.com

GE Evolve™

LED Roadway Lighting

ERLC



Project name _____

Date _____

Type _____

Typical Specifications: ERLC

LED & Optical

- **Output Range:** 1,860 - 6,350 lm
- **Photometric Options:** Type II Narrow, Type II/III^, Type III, Type V.
- **System Efficacy:** 102-133
- **CCT:** 2700K, 3000K, 4000K, 5000K
High Brightness LED's @ 70 CRI Minimum

Lumen Maintenance Tables

Projected Lxx per IES TM-21 at 25°C for reference:

ERLC LUMEN OUTPUT CODES	DISTRIBUTIONS	LXX(10K)@HOURS		
		25,000 HR	50,000 HR	60,000 HR
02, 03, 04	A4, B4, C4	L96	L95	L94
05	A4, B4, C4	L94	L90	L89
06	A4, B4, C4	L90	L80	L77

ERLC LUMEN OUTPUT CODES	DISTRIBUTIONS	LXX(10K)@HOURS		
		25,000 HR	50,000 HR	60,000 HR
02, 03, 04, 05	V4	L96	L93	L93
06	V4	L94	L89	L88

Note: Projected Lxx based on LM80 (10,000 hour testing). DOE Lighting Facts Verification Testing Tolerances apply to initial luminous flux and lumen maintenance measurements.

Electrical

- **Input Voltage:** 120-277 volt. (no 347-480V)
- **Input Frequency:** 50/60Hz
- **Power Factor (PF)*:** > 90%
- **Total Harmonic Distortion (THD)*:** <20%

*System PF and THD specified at rated watts

Ratings

- **Surge Protection:** Per ANSI C136.2-2015
— 10kV/5kA "Enhanced: (40 Strikes)" - Standard on ERLC (02 - 06)
- **Safety:** UL/cUL Listed. UL 1598 listed, suitable for wet locations.
- **Environmental:** Compliant with the materials restrictions of RoHS.
- **EMI:** Title 47 CFR Part 15 Class A
- **Vibration:** 3G per ANSI C136.31-2010
- LM-79 testing in accordance with IESNA Standards
- **Ingress Rating:** IP66 optical enclosure rated per ANSI C136.25-2013
- **Impact:** IK08 Lens

- **Operating Temperature:**

PRODUCT ID	LUMEN OUTPUT	AMBIENT READING
ERLC	02-06	-40°C to 50°C

Construction & Finish

- **Housing:**
 - Aluminum Die Cast Enclosure
 - Casting-integral heat sink for maximum heat transfer
- **Lensing:** Impact resistant tempered glass, standard
- **Paint:** Corrosion resistant polyester powder painted, minimum 2.0 mil. thickness.
 - Standard Colors: Gray, Black, Dark Bronze & White
 - RAL & custom colors available
 - Optional coastal finish available.
- **Weight:** 8.5 Lbs

Warranty

- **System Warranty:** 5 Year Standard, 10 Year Optional

Controls

- **Dimming:**
 - Standard: 0-10V; Optional: DALI (Option U)
- **Sensors:**
 - Photo electric sensors (PE) available.
 - LightGrid™ compatible

Mounting

- Adjustable for 1.25 to 2 in. nominal mounting pipe
- Integral diecast mounting pipe stop
- Slipfitter with +/- 5 degrees of leveling adjustment

Suggested HID Replacement Lumen Levels

- ~2,000–6,000 lumens to replace 50-100W HPS Cobra-head

Note: Actual replacement lumens may vary based upon mounting height, pole spacing, design criteria, etc.

PREVIOUS	DESCRIPTION	CURRENT	DESCRIPTION
A3	Type II Narrow	A4	Type II Narrow
B3	Type II Wide	B4	Type II/III^
C3	Type III	C4	Type III
D3	Type IV	None	
E3	Type II Enhanced Backlight	None	
		V4	Type V

**The information above is designed to provide a guideline to select the correct luminaire for a roadway application. The best and most accurate way to ensure the proper design is do a lighting layout.

^ See Page 5 for the typical ISO Plot of the B4 distribution. This optic is designed to address a Roadway Photometric Application and may classify as Type II or III.

GE Evolve™

LED Roadway Lighting

ERLC



Project name _____
 Date _____
 Type _____

ERLC

PROD. ID	VOLTAGE	LUMEN OUTPUT	DISTRIBUTION*	CCT	CONTROLS	COLOR	OPTIONS
E = Evolve R = Roadway L = Local C = Compact	0 = 120-277V* 1 = 120 2 = 208 3 = 240 4 = 277 8 = 120-240V* *Not available with fusing.	02* 03 04 05 06 *02 Lumen choice only offered for 120-240V.	A4 = Type II Narrow B4 = Type II/III^ C4 = Type III V4 = Type V	27 = 2700K 30 = 3000K 40 = 4000K 50 = 5000K	A = ANSI C136.41 7-pin D = ANSI C136.41 7-pin receptacle with Shorting Cap E = ANSI C136.41 7-pin receptacle with non-Dimming PE Control NOTE: Dimming controls wired for 0-10V standard unless DALI option "U" requested.	GRAY = Gray BLCK = Black DKBZ = Dark Bronze WHITE = White	B = Tether C1 = Captive Door F = Fusing G = Internal Bubble Level L = Tool-Less Entry M1 = Magnapak** R = Optional Secondary Enhanced Surge Protection (10kV/5kA) U = DALI Programmable + V1 = Variable Output via Field Adjustable Module*** Y = Coastal Finish* XXX = Special Options * Recommended for installations within 750 ft. from the coast. Contact Factory for Lead-Time. + Compatible with LightGrid 2.0 nodes. ** 40 fixtures per Magnapak ***No DALI available (U) or Fusing (F). System PF and THD specified at rated watts.

LUMEN OUTPUT	DISTRIBUTION	TYPICAL INITIAL LUMENS			TYPICAL SYSTEM WATTAGE	BUG RATING			IES FILE NUMBER			
		4000K/5000K	3000K	2700K		4000K/5000K	3000K	2700K	5000K	4000K	3000K	2700K
02	A4	1960	1920	1860	15	B1-U0-G1	B1-U0-G1	B1-U0-G1	ERLC_02A450_-120-240V.IES	ERLC_02A440_-120-240V.IES	ERLC_02A430_-120-240V.IES	ERLC_02A427_-120-240V.IES
	B4	2000	1960	1900		B1-U0-G1	B1-U0-G1	B1-U0-G1	ERLC_02B450_-120-240V.IES	ERLC_02B440_-120-240V.IES	ERLC_02B430_-120-240V.IES	ERLC_02B427_-120-240V.IES
	C4	2000	1960	1900		B1-U0-G1	B1-U0-G1	B1-U0-G1	ERLC_02C450_-120-240V.IES	ERLC_02C440_-120-240V.IES	ERLC_02C430_-120-240V.IES	ERLC_02C427_-120-240V.IES
	V4	1990	1950	1890		B1-U0-G0	B1-U0-G0	B1-U0-G0	ERLC_02V450_-120-240V.IES	ERLC_02V440_-120-240V.IES	ERLC_02V430_-120-240V.IES	ERLC_02V427_-120-240V.IES
03	A4	2940	2880	2800	23	B1-U0-G1	B1-U0-G1	B1-U0-G1	ERLC_03A450_-120-277V.IES	ERLC_03A440_-120-277V.IES	ERLC_03A430_-120-277V.IES	ERLC_03A427_-120-277V.IES
	B4	3000	2940	2860		B1-U0-G1	B1-U0-G1	B1-U0-G1	ERLC_03B450_-120-277V.IES	ERLC_03B440_-120-277V.IES	ERLC_03B430_-120-277V.IES	ERLC_03B427_-120-277V.IES
	C4	3000	2940	2860		B1-U0-G1	B1-U0-G1	B1-U0-G1	ERLC_03C450_-120-277V.IES	ERLC_03C440_-120-277V.IES	ERLC_03C430_-120-277V.IES	ERLC_03C427_-120-277V.IES
	V4	3100	3030	2950		B1-U0-G0	B1-U0-G0	B1-U0-G0	ERLC_03V450_-120-277V.IES	ERLC_03V440_-120-277V.IES	ERLC_03V430_-120-277V.IES	ERLC_03V427_-120-277V.IES
04	A4	3920	3840	3730	32	B1-U0-G1	B1-U0-G1	B1-U0-G1	ERLC_04A450_-120-277V.IES	ERLC_04A440_-120-277V.IES	ERLC_04A430_-120-277V.IES	ERLC_04A427_-120-277V.IES
	B4	4000	3920	3810		B1-U0-G1	B1-U0-G1	B1-U0-G1	ERLC_04B450_-120-277V.IES	ERLC_04B440_-120-277V.IES	ERLC_04B430_-120-277V.IES	ERLC_04B427_-120-277V.IES
	C4	4000	3920	3810		B1-U0-G2	B1-U0-G2	B1-U0-G2	ERLC_04C450_-120-277V.IES	ERLC_04C440_-120-277V.IES	ERLC_04C430_-120-277V.IES	ERLC_04C427_-120-277V.IES
	V4	4030	3940	3840		B2-U0-G0	B2-U0-G0	B2-U0-G0	ERLC_04V450_-120-277V.IES	ERLC_04V440_-120-277V.IES	ERLC_04V430_-120-277V.IES	ERLC_04V427_-120-277V.IES
05	A4	4900	4800	4670	43	B1-U0-G1	B1-U0-G1	B1-U0-G1	ERLC_05A450_-120-277V.IES	ERLC_05A440_-120-277V.IES	ERLC_05A430_-120-277V.IES	ERLC_05A427_-120-277V.IES
	B4	5000	4900	4760		B1-U0-G2	B1-U0-G2	B1-U0-G2	ERLC_05B450_-120-277V.IES	ERLC_05B440_-120-277V.IES	ERLC_05B430_-120-277V.IES	ERLC_05B427_-120-277V.IES
	C4	5000	4900	4760		B1-U0-G2	B1-U0-G2	B1-U0-G2	ERLC_05C450_-120-277V.IES	ERLC_05C440_-120-277V.IES	ERLC_05C430_-120-277V.IES	ERLC_05C427_-120-277V.IES
	V4	5200	5090	4950		B2-U0-G0	B2-U0-G0	B2-U0-G0	ERLC_05V450_-120-277V.IES	ERLC_05V440_-120-277V.IES	ERLC_05V430_-120-277V.IES	ERLC_05V427_-120-277V.IES
06	A4	5880	5760	5600	55	B1-U0-G1	B1-U0-G1	B1-U0-G1	ERLC_06A450_-120-277V.IES	ERLC_06A440_-120-277V.IES	ERLC_06A430_-120-277V.IES	ERLC_06A427_-120-277V.IES
	B4	6000	5880	5700		B1-U0-G2	B1-U0-G2	B1-U0-G2	ERLC_06B450_-120-277V.IES	ERLC_06B440_-120-277V.IES	ERLC_06B430_-120-277V.IES	ERLC_06B427_-120-277V.IES
	C4	6000	5880	5700		B1-U0-G2	B1-U0-G2	B1-U0-G2	ERLC_06C450_-120-277V.IES	ERLC_06C440_-120-277V.IES	ERLC_06C430_-120-277V.IES	ERLC_06C427_-120-277V.IES
	V4	6350	6220	6050		B2-U0-G1	B2-U0-G1	B2-U0-G1	ERLC_06V450_-120-277V.IES	ERLC_06V440_-120-277V.IES	ERLC_06V430_-120-277V.IES	ERLC_06V427_-120-277V.IES

^ See Page 5 for the typical ISO Plot of the B4 distribution. This optic is designed to address a Roadway Photometric Application and may classify as Type II or III.

Photometrics: Evolve™ LED Streetlight (ERLC)

ERLC
Type II Narrow
(05A440)

4,900 Lumens
4000K
ERLC_05A440___.IES



Grid Distance in Units of Mounting Height at 30'
Initial Footcandle Values at Grade

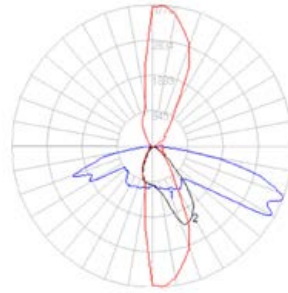

— Vertical plane through horizontal angle of Max. Cd at 85°
— Horizontal cone through vertical angle of Max. Cd at 67°

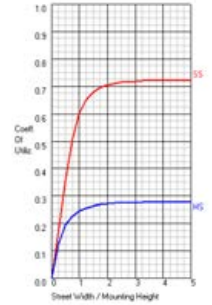

ERLC
Type II/III^
(05B440)

5,000 Lumens
4000K
ERLC_05B440___.IES

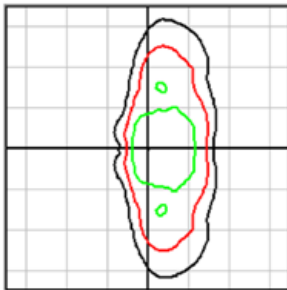

Grid Distance in Units of Mounting Height at 30'
Initial Footcandle Values at Grade

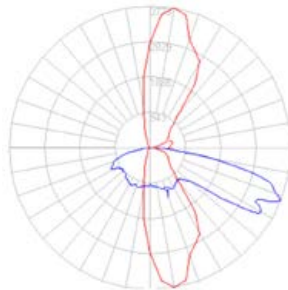

— Vertical plane through horizontal angle of Max. Cd at 80°
— Horizontal cone through vertical angle of Max. Cd at 68°

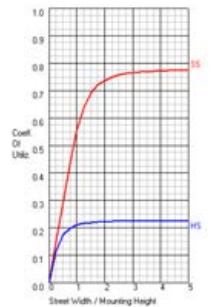

ERLC
Type III
(05C440)

5,000 Lumens
4000K
ERLC_05C440___.IES

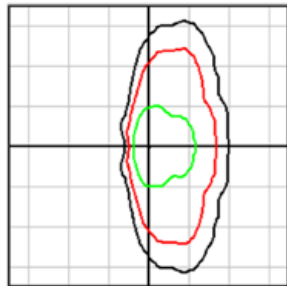

Grid Distance in Units of Mounting Height at 30'
Initial Footcandle Values at Grade

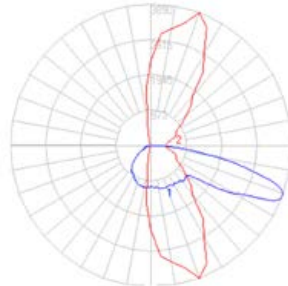

— Vertical plane through horizontal angle of Max. Cd at 70°
— Horizontal cone through vertical angle of Max. Cd at 68°

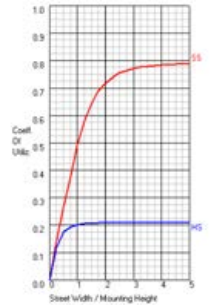

ERLC
Type V
(05V440)

5,200 Lumens
4000K
ERLC_05V440___.IES

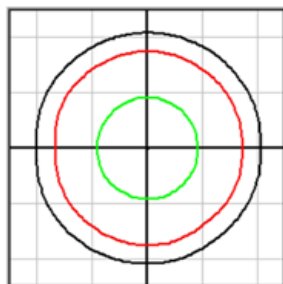

Grid Distance in Units of Mounting Height at 30'
Initial Footcandle Values at Grade

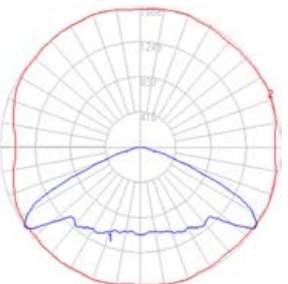

— Vertical plane through horizontal angle of Max. Cd at 55°
— Horizontal cone through vertical angle of Max. Cd at 64°

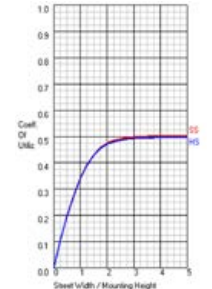

GE Evolve™
 LED Roadway Lighting
 ERLC

Product Dimensions:
 Evolve™ LED Streetlight (ERLC)

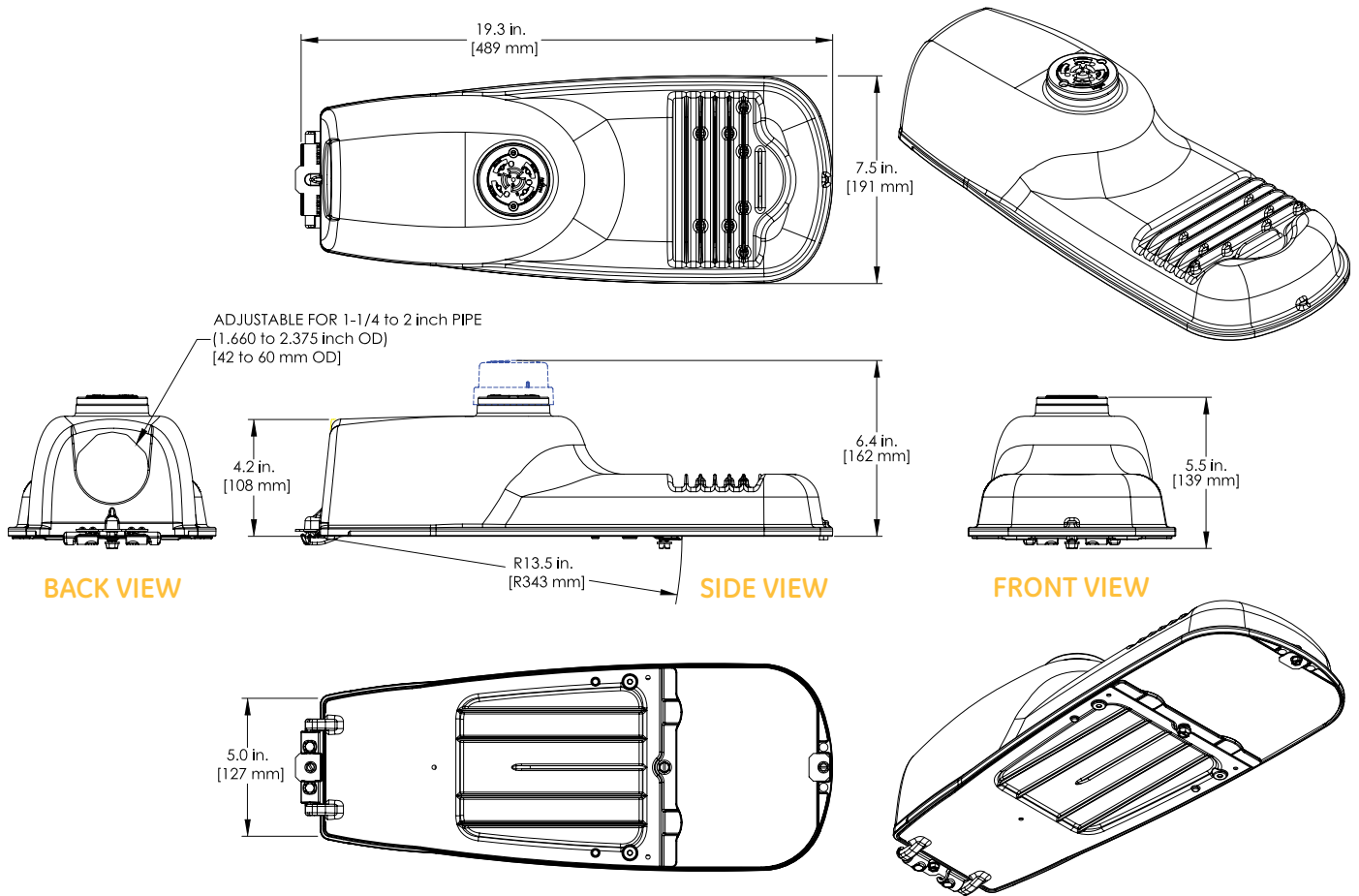

DATA

- Approximate net weight: 8.5 lbs (3.8 kgs)
 Contact manufacturer for specific configuration weight.
- Effective Projected Area (EPA): 0.3 sq ft max (0.029 sq m)