

ELEVATION - PEDESTRIAN RAILS ATTACHED TO TYP. CL-2 OR CL-3 GUARDRAIL
1:100

NOTE: HANDRAIL & FOOT RAIL SPLICES NOT TO BE LOCATED BETWEEN SAME POSTS AS VEHICLE RAIL SPLICE

NOTE: HANDRAIL & FOOT RAIL UNSPLICED LENGTHS MUST SPAN MIN. 2 POSTS

NOTES

1.0 GENERAL

-THE PROFESSIONAL ENGINEER RESPONSIBLE FOR PRESCRIBING FLNRO STANDARD BRIDGE PEDESTRIAN RAILINGS, AS SHOWN ON THESE DRAWINGS, MUST EVALUATE THE SUITABILITY OF THEIR USE BASED ON AN ASSESSMENT OF THE SPECIFIC BRIDGE CHARACTERISTICS AND SITE CONDITIONS INCLUDING: BRIDGE BARRIER CONFIGURATION AND CONNECTION CAPACITY, BRIDGE WIDTH, ROAD APPROACHES AND ALIGNMENT, ANTICIPATED VEHICLE TRAFFIC CONFIGURATIONS, ETC.

-STANDARD PEDESTRIAN RAILINGS (2 HANDRAILS PLUS 1 FOOT RAIL) ARE DESIGNED FOR ATTACHMENT TO MINISTRY STANDARD CL-2 AND CL-3 VEHICLE GUARDRAILS (DESIGNED BY OTHERS) WHERE IT IS DESIRED THAT PEDESTRIANS AND VEHICLES SHARE BRIDGE USE WITHOUT A DEDICATED PEDESTRIAN WALKWAY/SIDEWALK. THE RESULTING BARRIER IS CONSIDERED TO BE A COMBINATION (VEHICLE + PEDESTRIAN) BARRIER AS PER CANADIAN HIGHWAY BRIDGE DESIGN CODE (CHBDC).

-THIS DRAWING TO BE READ TOGETHER WITH STD-EC-010-02 "STANDARD BRIDGE GUARDRAIL-HSS RAIL CL-2", OR STD-EC-010-03 "STANDARD BRIDGE GUARDRAIL-HSS RAIL CL-3", OR STD-EC-010-06 "STANDARD HSS GUARDRAIL FOR PRECAST CONCRETE SLAB BRIDGES CL-3".

-THE PEDESTRIAN RAILING COMPONENTS ARE DESIGNED USING THE FOLLOWING PEDESTRIAN LOADING AND GEOMETRIC REQUIREMENTS DRAWN FROM CHBDC:

- DESIGN LOADS FOR PEDESTRIAN RAILINGS = UNIFORMLY DISTRIBUTED LOAD of 1.20 kN/m - SIMULTANEOUS LATERAL AND VERTICAL, AS PER CHBDC CL. 3.8.8.2.
- TOP OF PEDESTRIAN RAILING HEIGHT = 1050 mm (CL-2) OR 1100 mm (CL-3), TO MEET MINIMUM HEIGHT REQUIREMENTS AS PER CHBDC TABLE 12.8.
- VERTICAL SPACING BETWEEN RAILS DESIGNED TO MEET THE GENERAL INTENT OF CHBDC REQUIREMENTS FOR PEDESTRIAN/VEHICLE COMBINATION BARRIERS.

2.0 MATERIALS

- HSS: F_y MIN. 345MPa, CSA G40.21M OR ASTM A500 GRADE C
- OTHER SECTIONS: F_y MIN. 345MPa, CSA G40.21M OR ASTM A572 GRADE 50
- PLATE: F_y MIN. 300W OR 350W, CSA G40.21M
- BOLTS: ASTM A307
- CARRIAGE BOLTS TO HAVE A ROUND HEAD AND A SQUARE NECK
- ROUND BAR: ASTM A36
- NUTS: ASTM A563
- STANDARD WASHERS: ASTM F844
- PLATE WASHERS: MILD STEEL (I.D. \sim 2MM > BOLT DIAMETER)
- ALL MATERIALS TO BE GALVANIZED TO CSA G164, MIN. 610 g/m², OR ASTM A123
- ALL STEEL TO BE GALVANIZED SHALL MEET CHEMICAL COMPOSITION RECOMMENDATIONS AS SPECIFIED BY THE AMERICAN GALVANIZERS ASSOCIATION (AVAILABLE AT WWW.GALVANIZEIT.ORG) TO ENSURE AGAINST EMBRITTLEMENT.

3.0 FABRICATION AND INSTALLATION

- WELDING IN ACCORDANCE WITH CSA W59 BY COMPANY CERTIFIED TO CSA W47.1 FOR DIVISION 1, 2, OR 3
- BOLT HOLE DIAMETERS: 2mm > BOLT DIAMETER, UNLESS NOTED OTHERWISE (UNO)
- ALL NUTS SHALL BE SNUG-TIGHTENED (THE CONDITION THAT BRINGS THE PLIES INTO FIRM CONTACT COMMONLY ATTAINED BY A FEW IMPACTS OF AN IMPACT WRENCH, OR THE FULL EFFORT OF AN IRONWORKER USING AN ORDINARY SPUD WRENCH).

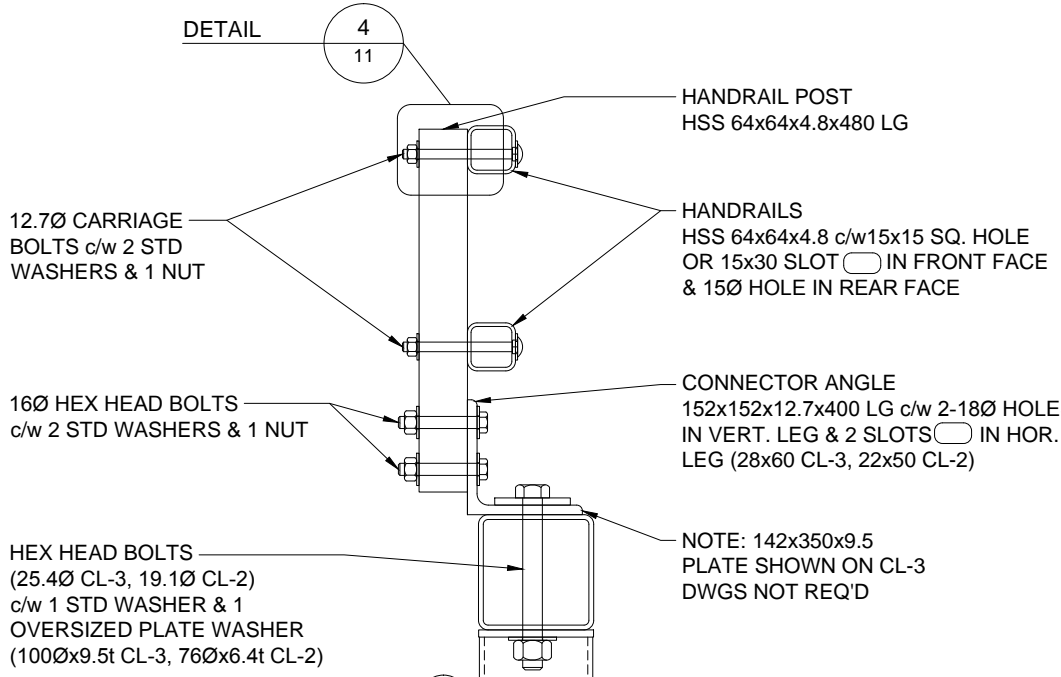

SECTION B-B: HANDRAIL ASSEMBLY (REAR MOUNTED OPTION SHOWN ON CL-3)
1:10

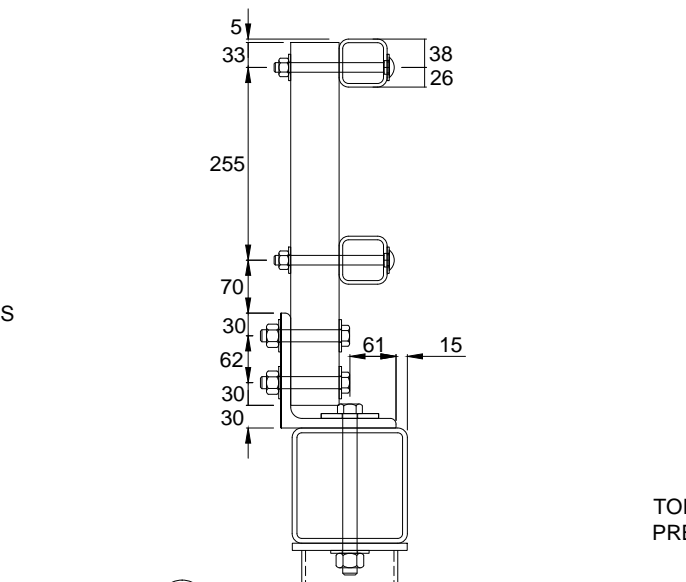

SECTION B-B: HANDRAIL ASSEMBLY DIMENSIONS (FRONT MOUNTED OPTION SHOWN ON CL-2)
1:10

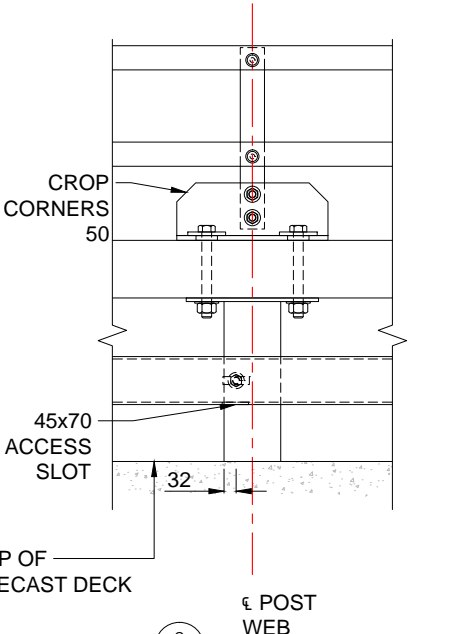

SECTION C-C: TYP. FRONT FACE (REAR MOUNTED OPTION ON CL-3 SHOWN)
1:20

NOTE: FRONT MOUNTED OR REAR MOUNTED HANDRAIL ASSEMBLY OPTION MAY BE USED ON CL-2 OR CL-3. CHOICE OF OPTION TO BE SPECIFIED BY MINISTRY BRIDGE ENGINEER IN CONSIDERATION OF SITE SPECIFIC REQUIREMENTS.

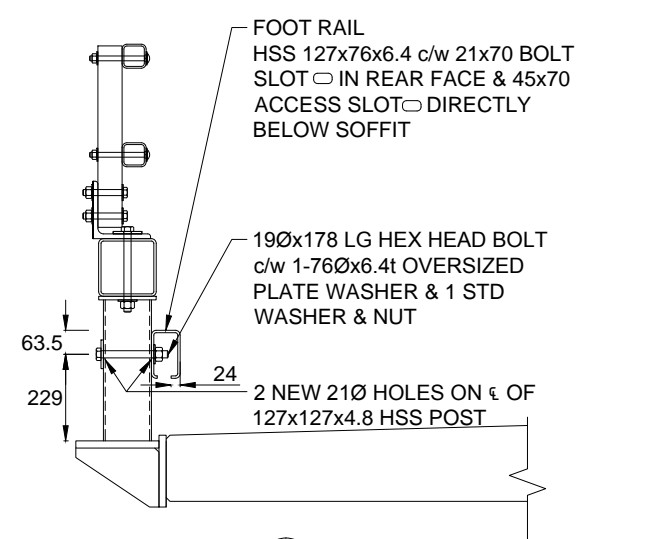

SECTION A-A: CL-2 FOOT RAIL DETAILS
1:20

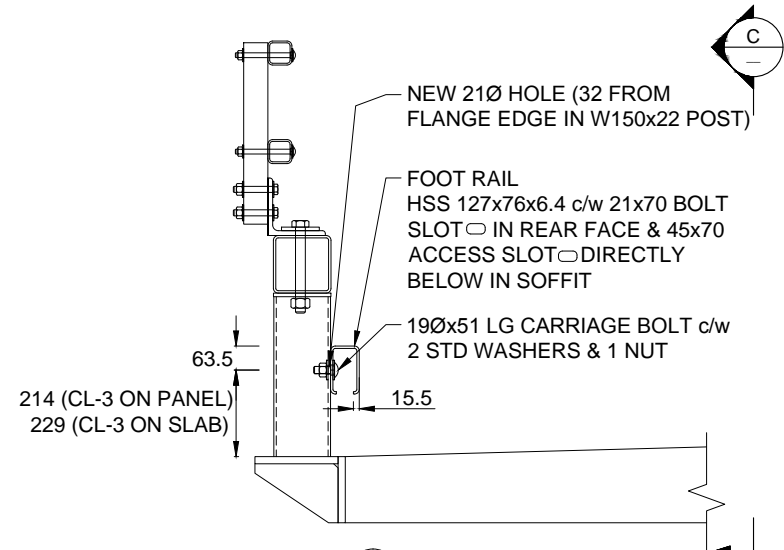

SECTION A-A: CL-3 FOOT RAIL DETAILS
1:20

**ASSUME NOT TO SCALE
NOT FOR CONSTRUCTION**



SCALE AS SHOWN		Designed <u>M.P.</u>	Date <u>Mar. 31, 2017</u>
		Checked <u>J.N.</u>	Date <u>Mar. 31, 2017</u>
		Drawn <u>N.H.</u>	Date <u>Mar. 31, 2017</u>
REV	DATE	DESCRIPTION	INITIAL
REVISIONS			

STANDARD BRIDGE DRAWING	
STANDARD BRIDGE PEDESTRIAN RAILINGS FOR ATTACHMENT TO CL-2 & CL-3 GUARDRAILS - DWG. 1 OF 2	
ORIGINAL SIGNED and SEALED BY: M. PENNER, P.ENG.	APPROVED BY: B. CHOW, P.ENG., CHIEF ENGINEER
FILE NUMBER:	DRAWING NUMBER: STD-EC-010-10
	0