

**AGGREGATE OPERATORS  
BEST MANAGEMENT PRACTICES  
HANDBOOK**

for

**BRITISH COLUMBIA**

**VOLUME II**

**Best Management  
Practices**

(Volume I - Introduction & Planning  
as separate printable document)



BRITISH  
COLUMBIA

MINISTRY OF  
ENERGY & MINES

**April 2002**

# PART III - BEST MANAGEMENT PRACTICES

## Chapter 7 Best Management Practices

	page
Introduction .....	1
How to Chose BMPs .....	1
1. Refer to Table 7-1 and 7-2 BMP Module Reference Charts.....	1
2. Review Topical Modules for Suggestions.....	1
3. Flip through BMPs.....	1
Additional BMP Websites .....	2
BMP - Module Reference Chart .....	4
BMP - Module Reference Chart - Alphabetic .....	6
<b>Best Management Practices</b>	
Backfilling .....	8
Berm.....	10
Bioengineering .....	12
Buffer Zone .....	15
Check Dam .....	18
Constructed Wetlands.....	21
Ditches .....	23
Drop Height.....	25
Dust Skirt.....	26
Environmental Timing Windows.....	27
Equipment Selection .....	30
Erosion Control Blanket .....	32
Fences .....	34
French Drain .....	36
Grading .....	38
Haul Road .....	41
Lighting Management.....	45
Material Corrals.....	47
Oil/Water Separator .....	49
Outlet Protection .....	51
Pollution Prevention .....	53
Retention Basin.....	55
Scheduled Maintenance & Repairs.....	59
Settling Pond.....	60
Signage .....	63
Silt Fence .....	65
Sinking the Plant .....	68
Slope Drain .....	69
Street Cleaning .....	71
Tarp.....	72
Tillage.....	74
Topsoil Management.....	76
Vegetation Cover .....	79
Vibration Reduction.....	81
Water Spray .....	82
Wheel Washer.....	84
Wind Protection .....	86

# Chapter 7

## Best Management Practices

---

### Introduction

This chapter of the handbook presents thirty-seven Best Management Practices (BMPs). The BMPs have been selected for specific application in aggregate operations. There are, however, many "general reference" BMPs that can also be useful. Three recommended websites are:

1. *Water Related BMP's in the Landscape*. Watershed Science Institute. URL <<http://www.abe.msstate.edu/csd/NRCS-BMPs/>>, October 2001
2. *Best Management Practices for Reclaiming Surface Mines in Washington and Oregon*. URL <<http://www.wa.gov/dnr/htdocs/ger/pdf/bmp.pdf>> [PDF, 7.6 Mb], June 2001, and
3. *Stormwater Management Manual for Western Washington*, Volumes I-5 Washington State Department of Ecology, URL <<http://www.ecy.wa.gov/biblio/9911.html>>, June 2001 (scroll to the bottom of the page for links to volume 2-5).

Also see the "Additional BMP Websites" section at the end of this introduction.

### How to Chose BMPs

There are three ways to select a BMP from this handbook:

#### **1. Refer to Table 7-1 and 7-2 BMP Module Reference Charts.**

In these charts, BMPs are cross-referenced against Module topics (extraction, traffic, etc.). Table 7-1 organizes the BMP's into five thematic groupings (Stormwater Management, Erosion Control, Noise and Dust, Risk Management and Pollution Prevention), while Table 7-2 lists them alphabetically.

#### **2. Review Topical Modules for Suggestions**

Tables within the Chapter 5 modules suggest specific BMPs to address specific problems.

#### **3. Flip Through the BMPs in Chapter 7**

The BMPs in Chapter 7 all have a "USE" box in the upper right hand corner of the first page. They can be selected by simply looking for a "USE" box with an appropriate application.

## Additional BMP Websites

British Columbia Ministry of Water, Land and Air Protection. (2001): **Environmental Objectives, Best Management Practices and Requirements for Land Developments**. BC Environment, Vancouver Island Region, URL <[http://wapwww.gov.bc.ca/vir/pa/bmp\\_dev1.htm](http://wapwww.gov.bc.ca/vir/pa/bmp_dev1.htm)>, October 2001.

British Columbia Ministry of Water, Land and Air Protection. (2001): **Best Management Practices To Protect Water Quality**. Water Quality Branch, URL <[http://wapwww.gov.bc.ca/wat/wq/NPS\\_web\\_page/BMP\\_Compendium/BMP\\_Introduction/BMP\\_Home.htm](http://wapwww.gov.bc.ca/wat/wq/NPS_web_page/BMP_Compendium/BMP_Introduction/BMP_Home.htm)>, October 2001.

Chilibeck, B., Chislett, G. and Norris, G. (1992): **Land Development Guidelines for the Protection of Aquatic Habitat**; *Department of Fisheries and Oceans, and Ministry of Environment, Lands and Parks*, URL <<http://www-heb.pac.dfo-mpo.gc.ca/english/publications/PDF/guidelines/ldg.PDF>> [PDF, 1.5 Mb], June 2001.

Ciuba, S. and Austin, L. (2001): **Runoff Treatment BMPs**; in Stormwater Management Manual for Western Washington, Volume V; *Washington State Department of Ecology*, Publication 9915, URL <<http://www.ecy.wa.gov/biblio/9915.html>>, June 2001.

Cole, L., Smith, P., Wright, J. and Clough, R. (1999): **Controlling the Environmental Effects of Recycled and Secondary Production Good Practice Guidance**; *United Kingdom Department of the Environment, Transportation and the Regions*, URL <<http://www.planning.detr.gov.uk/recycled/practice/index.htm>>, June 2001.

Coulter, T.S. and Halladay, D.R. (1997): **Manual of Control of Erosion and Shallow Slope Movement**; *Ministry of Transportation and Highways*, Vancouver Island Highway Project.

Field, L.Y. and Engel, B.A. **Best Management Practices for Soil Erosion**; *Purdue University, Agricultural and Biological Engineering Department*, URL <<http://pasture.ecn.purdue.edu/AGEN521/epadir/erosion/asm521.html>>, October 2001.

Norman, D.K., Wampler, P.J., Throop, A.H., Schnitzer, E.F. and Roloff, J.M. (1997): **Best Management Practices for Reclaiming Surface Mines in Washington and Oregon**; *Washington State Department of Natural Resources Open File Report 96-2 and Oregon Department of Geology and Mineral Industries Open File Report O-96-2*, 128 pages, URL <<http://www.wa.gov/dnr/htdocs/ger/pdf/bmp.pdf>> [PDF, 7.6 Mb], June 2001.

O'Brien, E. (2001): **Minimum Technical Requirements**; Stormwater Management Manual for Western Washington, Volume I. *Washington State Department of Ecology*, Publication 9911, URL <<http://www.ecy.wa.gov/biblio/9911.html>>, June 2001.

Thomas, M., Editor (2000): **Controlling and Mitigating the Environmental Effects of Minerals Extraction in England Consultation Paper**; Mineral Planning Guidance Note 11. *United Kingdom Department of the Environment, Transportation and the Regions*, URL <<http://www.planning.detr.gov.uk/consult/mpg11/index.htm>>, June 2001.

United States Department of Agriculture and Mississippi State University. (1999): **Water Related BMP's in the Landscape**; *Watershed Science Institute*. Created for the *Natural Resource Conservation Service, United States Department of Agriculture* by the *Center for Sustainable*

*Design Mississippi State University Departments of Landscape Architecture, Agricultural and Biological Engineering, and the College of Agriculture and Life Sciences, URL*  
<<http://www.abe.msstate.edu/scd/NRSC-BMPs/index.html>>, October 2001.

Table 7 - 1: BMP - Module Reference Chart

GROUP/IN	MODULES Topics:	EM	PM	SM	TM	SECM	BWM	SLM			RM					
		Extraction	Processing	Stockpiling	Traffic	Stormwater & Erosion	By-product & Waste	Noise	Dust	Visual Landscape	Risk Management	Emergency Spill Rsep.	Employee Training	ID Env. Issues	Community Relations	BMP Monitoring
Stormwater Mgmt	Buffer Zone	✓	✓	✓		✓		✓	✓	✓		✓		✓	✓	✓
	Check Dams			✓		✓								✓	✓	✓
	Constructed Wetlands		✓			✓				✓				✓	✓	✓
	Ditches		✓	✓		✓										✓
	French Drain					✓										✓
	Retention Basin					✓										✓
	Silt Fence	✓		✓		✓			✓							✓
	Slope Drain					✓										✓
Erosion Control	Backfilling	✓	✓	✓		✓	✓	✓								
	Bioengineering			✓		✓			✓	✓						✓
	Erosion Control Blanket	✓		✓		✓			✓	✓						✓
	Grading	✓	✓	✓		✓	✓		✓	✓						
	Outlet Protection		✓			✓					✓	✓				✓
	Tarps		✓	✓	✓	✓			✓							✓
	Tillage	✓		✓		✓			✓							✓
	Topsoil management		✓	✓		✓			✓							✓
Noise and Dust	Vegetation Cover	✓		✓		✓		✓	✓	✓				✓	✓	✓
	Berm			✓		✓	✓	✓	✓	✓					✓	✓
	Drop Height	✓	✓	✓	✓			✓	✓							✓
	Dust Skirt	✓	✓	✓	✓				✓							✓
	Equipment Selection	✓	✓	✓	✓		✓	✓	✓			✓	✓		✓	
	Haul Roads				✓	✓		✓	✓	✓	✓	✓		✓	✓	✓
	Material Corrals		✓	✓	✓	✓	✓		✓	✓	✓					✓
	Sinking the Plant		✓		✓			✓	✓	✓						✓
	Street Cleaning		✓		✓	✓	✓		✓	✓				✓	✓	✓
	Vibration Reduction	✓	✓		✓	✓			✓	✓		✓			✓	✓
	Water Spray	✓	✓	✓	✓	✓			✓							✓
	Wheel Washer		✓		✓	✓			✓	✓	✓				✓	✓
Wind Protection			✓					✓	✓	✓					✓	

	<b>MODULES</b>	<b>EM</b>	<b>PM</b>	<b>SM</b>	<b>TM</b>	<b>SECM</b>	<b>BWM</b>		<b>SLM</b>		<b>RM</b>					
<b>GROUP/IN</b>	<b>Topics:</b>	Extraction	Processing	Stockpiling	Traffic	Stormwater & Erosion	By-product & Waste	Noise	Dust	Visual Landscape	Risk Management	Emergency Spill Rsep.	Employee Training	ID Env. Issues	Community Relations	BMP Monitoring
<b>BMPs</b>	Env. Timing Windows	✓	✓	✓				✓			✓			✓		✓
	Fences			✓		✓		✓	✓	✓				✓	✓	✓
	Lighting Management	✓	✓	✓						✓	✓	✓		✓	✓	✓
	Signage									✓	✓	✓	✓		✓	✓
<b>Pollution</b>	Oil/Water Separator		✓			✓	✓					✓				✓
	Pollution Prevention	✓	✓	✓	✓	✓	✓				✓	✓	✓			✓
	Scheduled Maintenance	✓	✓		✓		✓	✓	✓			✓	✓			✓
	Settling Pond		✓	✓		✓	✓									✓

Table 7 - 2: BMP - Module Reference Chart - Alphabetic

<b>MODULES</b>	<b>EM</b>	<b>PM</b>	<b>SM</b>	<b>TM</b>	<b>SEC</b>	<b>BWM</b>	<b>SLM</b>			<b>RMM</b>					
<b>Topics:</b>	<b>Extraction</b>	<b>Processing</b>	<b>Stockpiling</b>	<b>Traffic</b>	<b>Stormwater &amp; Erosion</b>	<b>By-product &amp; Waste</b>	<b>Noise</b>	<b>Dust</b>	<b>Visual Landscape</b>	<b>Risk Management</b>	<b>Emergency Spill Rsep.</b>	<b>Employee Training</b>	<b>ID Env. Issues</b>	<b>Community Relations</b>	<b>BMP Monitoring</b>
<b>BMPs</b>															
Backfilling	✓	✓	✓		✓	✓	✓								
Berm			✓		✓	✓	✓	✓	✓					✓	✓
Bioengineering			✓		✓			✓	✓						✓
Buffer Zone	✓	✓	✓		✓		✓	✓	✓		✓		✓	✓	✓
Check Dams			✓		✓										✓
Constructed Wetlands		✓			✓				✓				✓	✓	✓
Ditches		✓	✓		✓										✓
Drop Height	✓	✓	✓	✓			✓	✓							✓
Dust Skirt	✓	✓	✓	✓				✓							✓
Env. Timing Windows	✓	✓	✓				✓			✓			✓		✓
Equipment Selection	✓	✓	✓	✓		✓	✓	✓			✓	✓		✓	
Erosion Control Blanket	✓		✓		✓			✓							✓
Fences			✓		✓		✓	✓	✓				✓	✓	✓
French Drain					✓										✓
Grading	✓	✓	✓		✓	✓		✓	✓						
Haul Roads				✓	✓		✓	✓	✓	✓			✓	✓	✓
Lighting Management	✓	✓	✓						✓	✓	✓		✓	✓	✓
Material Corrals		✓	✓	✓	✓	✓		✓	✓						✓
Oil/Water Separator		✓			✓	✓					✓				✓
Outlet Protection		✓			✓					✓	✓				✓
Pollution Provention	✓	✓	✓	✓	✓	✓				✓	✓	✓			✓
Retention Basin															✓
Scheduled Maintenance	✓	✓		✓		✓	✓	✓			✓	✓			✓
Settling Pond		✓	✓		✓	✓									✓
Signage									✓	✓	✓	✓		✓	✓
Silt Fence	✓		✓		✓			✓							✓
Sinking the Plant		✓		✓			✓	✓	✓						✓
Slope Drain					✓										✓



<b>MODULES</b>	<b>EM</b>	<b>PM</b>	<b>SM</b>	<b>TM</b>	<b>SEC</b>	<b>BWM</b>	<b>SLM</b>			<b>RMM</b>					
<b>Topics:</b>	Extraction	Processing	Stockpiling	Traffic	Stormwater & Erosion	By-product & Waste	Noise	Dust	Visual Landscape	Risk Management	Emergency Spill Rsep.	Employee Training	ID Env. Issues	Community Relations	BMP Monitoring
<b>BMPs</b>															
Street Cleaning		✓		✓	✓	✓		✓	✓				✓	✓	✓
Tarps		✓	✓	✓	✓			✓							✓
Tillage	✓		✓		✓			✓							✓
Topsoil management		✓	✓		✓			✓							✓
Vegetation Cover	✓		✓		✓		✓	✓	✓				✓	✓	✓
Vibration Reduction	✓	✓		✓			✓	✓		✓				✓	✓
Water Spray	✓	✓	✓	✓	✓			✓							✓
Wheel Washer		✓		✓	✓			✓	✓					✓	✓
Wind Protection			✓					✓	✓						✓

## What

- ✎ Using lifts of overburden or waste rock to restore a face or a mined out area to a specified reclamation slope.

## Purpose

- ✎ Reduces slope angles to specific or standard reclamation criteria.
- ✎ Can reduce the hazard of slope failure.
- ✎ Compaction may be required to achieve a specified minimum density.

## Where

**YES:** Where final face heights are higher and steeper than permit specifications or general reclamation standards.

## Materials, Equipment & Costs

- 🚛 Overburden, waste rock, construction or excavation materials.
- ✂ Haul truck, front-end loader, bulldozer, backhoe, sheep's foot roller and smooth vibrating drum roller.
- 💰 Variable, depending upon height, moisture content and post-extraction land use.

## Specs

- A sand and gravel or quarry permit may specify reclamation slope angles and compaction specifications (dry densities of backfilling material, standard proctor, and compaction techniques). If slope angles are not specified in the permit, use general reclamation slope angles of 2 horizontal to 1 vertical.
- If in doubt regarding reclamation specifications, contact a regional office of the Ministry of Energy and Mines or the Mines Branch, Geotechnical Section, in Victoria.
- After all mineable aggregate is removed from an area, slopes can be re-contoured by:
  - concurrent backfilling using overburden mined elsewhere on the site;
  - bringing in quality, clean fill material from construction projects or other sources offsite, and
  - retaining enough overburden or mine by-products for re-sloping.
- Backfilling is most efficient when stripped waste material is immediately placed into backfilling lifts. Using this approach, the material is handled only once, and its original moisture content may allow for the best compaction. The moisture content of stockpiled waste material may change during storage, making it difficult to achieve the required minimum density.
- Ensure that fill material is free of brush, rubbish, organics, logs, stumps, building debris and other materials inappropriate for constructing stable fills.
- Ensure that fills from unknown sources are free of contamination.
- Place fill in 6 centimeter layers, or other thickness specified in the design.

- Compact the layers to the required standard proctor dry density, as required, to ensure stability.
- Add water during compaction, as required to maintain optimum moisture content.
- Clay is best compacted with a sheep's foot roller, and granular material with a smooth vibrating drum roller.
- If overburden cannot be immediately placed into lifts, store the overburden where it can be readily and economically moved into position during reclamation.
- Plan stormwater drainage paths.

## Additional Considerations

- Stability and erosion control are primary concerns for backfilled slopes. Careful location of drains and water-control features will enhance slope stability and revegetation potential.
- If overburden or waste rock is strategically placed and there are no geotechnical concerns, backfilling may be done with a short push or haul.
- Back-slope benches should drain stormwater away from the crests.
- Backfilling areas proposed for buildings and roads may require increased density criteria and testing for control of compaction and grade.
- If permanent planting will be delayed, temporary protection of bare slopes against erosion with plastic sheeting, mulches, matting or seeding with grasses may be necessary.

## Options

- For sand and gravel pits, if no material is available for backfilling, simply knocking down the crest of the face can reduce the slope to the desired stable slope angle. Proper safety measures should be taken.

## Vegetation & Planting

- Vegetation can significantly reduce surface erosion, but cannot be relied upon to prevent movement of a soil that is unstable due to improper design and construction.
- Planning a phased succession for ground cover, grasses, shrubs and trees will establish good protection. Succession management involves the addition of naturally occurring types of plants, as the indigenous species create an environment in which further stages can flourish. For example, shade-loving species should not be planted in full sun, but would naturally begin to appear after the development of a canopy.

## Maintenance

- It is important to establish and maintain drainage to avoid flooding or erosion.
- Ensure that the vegetative cover is kept healthy, to avoid erosion.

## Sources

O'Brien, E. (2001): **Minimum Technical Requirements**; Stormwater Management Manual for Western Washington, Volume I. *Washington State Department of Ecology*, Publication 9911, URL <<http://www.ecy.wa.gov/biblio/9911.html>>, June 2001.

Norman, D.K., Wampler, P.J., Throop, A.H., Schnitzer, E.F. and Roloff, J.M. (1997): **Best Management Practices for Reclaiming Surface Mines in Washington and Oregon**; *Washington State Department of Natural Resources* Open File Report 96-2 and *Oregon Department of Geology and Mineral Industries* Open File Report O-96-2, page 5-5, URL <<http://www.wa.gov/dnr/htdocs/ger/pdf/bmp.pdf>> [PDF, 7.6 Mb] June 2001.

MAP CODE  
**BERM**

# BERM

**USE**  
Dust  
Noise  
Landscape

## What

- ☛ An elongated, raised barrier constructed of overburden, topsoil or aggregate by-product, commonly seeded with grass and topped with shrubs, trees and/or a fence.

## Purpose

- ☛ To intercept noise, dust and the views of an operation.
- ☛ For site security by deterring trespass.
- ☛ A storage option for overburden, waste rock or by-products and, at times, product.
- ☛ When well designed, constructed and vegetated, berms can help the operation to blend in with the landscape and the local community.

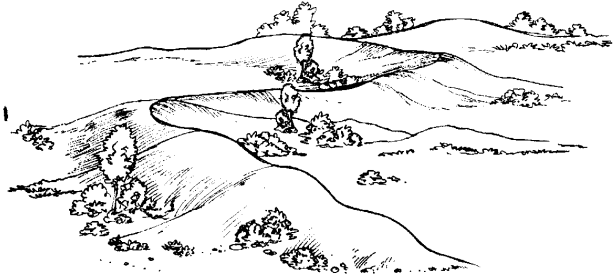

## Where

**YES:** Adjacent to noise, dust or visual impact sources; adjacent to areas sensitive to impacts (e.g., wetlands, schools, residential areas); around the perimeter of the property; most commonly located anywhere between operations and residential areas or public roads.

## Materials, Equipment & Costs

- ☛ Overburden, pit run, waste rock, aggregate by-products, sand or gravel, trees, shrubs, grass seed and fencing materials. Constructing a berm out of top soil may restrict the topsoil's availability for reclamation work.
- ☛ Haul truck, bulldozer, front-end loader and labour to plant vegetation and build fences.
- \$ Medium.

## Plans & Specs

- The slope, size, shape, grade and vegetation of the berm should blend into the local landscape and be similar to what is naturally found. Poorly planned and constructed berms may actually be an eyesore.
- Berm height to width ratios range from 1:5 to 1:10; tops are usually at least 2.0 metres above adjacent surfaces.
- Choose fertile, non-droughty soil materials to minimize the need for watering and ensure successful revegetation.
- A landscape architect or designer can be enlisted to help ensure the berms achieve their design goals, and can assist with the landscape planning.

- Examples of well-designed berms can often be found on golf courses.
- To achieve a more natural appearance, vary the height of the berms, widen them out or otherwise change their shape, and give them gentle curves.
- Round off the crest to facilitate planting.
- Blend the base into existing grades.
- Use landscaping to further blur the berm-grade line. For example, a lawn that exactly follows the toe of the slope is a dead giveaway. Instead, allow the lawn to cross the line in natural "mowable" curves.
- Retaining walls of concrete blocks can form the back of berms in tight spaces.
- Establish ground cover quickly, using sod if appropriate. Use geotextiles, straw matting, shrubs and trees to further reduce the erosion potential of the berm. Refer to Erosion Control Blanket BMP.

## Vegetation & Planting

- For noise and dust control and visual screening, plant a mix of fast-growing shrubs and deciduous trees with slower-growing evergreens. Weeping willow trees or various native willow shrubs add diversity.
- Before planting, consider the expected life span of the berm (5 year, 20 year, "permanent") and take into account the final land use and the role of the berm after the completion of the mine.
- For a more natural look, plant trees or shrubs in a staggered pattern off the crest of the berm, and plant in groupings rather than in rows.
- Berms usually drain well and dry out quickly, so select plants that are relatively drought tolerant or fit the mound with a drip irrigation or sprinkler system. Sprinklers also have the advantage of dust suppression abilities.
- For detailed information, refer to the Land Reserve Commission's (LRC) publication "[Landscape Buffer Specifications](#)," available at <http://www.landcommission.gov.bc.ca> under "Publications/ALR Topics/". This document was written for the agricultural industry, but also can be useful for aggregate operations.

## Maintenance

- Plants, shrubs and trees require maintenance such as fertilization, thinning and pruning. In creating inconspicuous buffers, consider a natural but neat look. Both finely sculpted hedges and dead snags may be undesirable.
- A regular program of irrigation, fertilization and weed control may be required.

## Sources:

Totten, L.B. (1997): **Outside Interests**; The Detroit News, 27 November, 1997.

Berger, P.R, Ford, W.C., Graham, E.K., Long, U.F., Rohrs, D.M., West, J.R. and Willard, R.B. (1990): **Environmental and Community Concerns**; in The Aggregate Handbook, Barksdale, R.D. Editor, National Stone Association.

Cole, L., Smith, P., Wright, J. and Clough, R. (1999): **Controlling the Environmental Effects of Recycled and Secondary Production Good Practice Guidance**; *United Kingdom Department of the Environment, Transportation and the Regions*, URL <http://www.planning.detr.gov.uk/recycled/practice/index.htm>, June 2001.

## What

- Erosion and sediment control structures made from stalks of live willow shrubs that continue to grow once emplaced into the soil.

## Purpose

- To prevent erosion with their physical structure until established plants can provide permanent erosion protection.
- To jump-start the establishment of self-sustaining vegetation on exposed hillsides and gullies, which stabilize the slopes and stop erosion and sediment production.

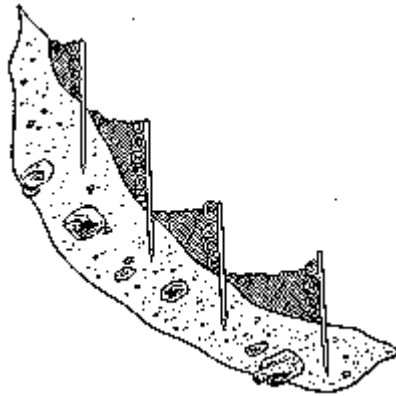

Source: Polster Environmental Services

**Wattle Fencing - Sideview**

## Where

- YES:** Areas of disturbed soil or hillsides, streambanks and lakeshores, and where soil stabilization and erosion control is required because of stormwater runoff or high water table.
- NO:** Areas where there is severe soil or water contamination, the stream bottom is degrading, human or animal traffic cannot be controlled, or where shade is too dense for selected plant species to thrive.

## Materials, Equipment & Costs

- 🛠️ Live willow stakes, timber stakes, twine, rope, pots or mats, plant material
- ⚒️ Backhoe, shovel, sledge hammer.
- 💰 Low to medium.

## Plans & Specs

- If using for first time, consider obtaining expert help from environmental or erosion control engineers and/or consultants.

## Options

- Wattle Fence  
Small retaining walls built of willow stakes. Useful on hill slopes and gullies with minimal ravelling.
- Modified Brush Layer  
Robust short retaining walls (1-2 metres wide) made with 2 metre long rough cut 2x6 planks or logs and live willow stakes. Excellent for stabilizing ravelling or actively eroding hill slopes and gullies. Used in patterns to give complete coverage of a hillside or gully wall.

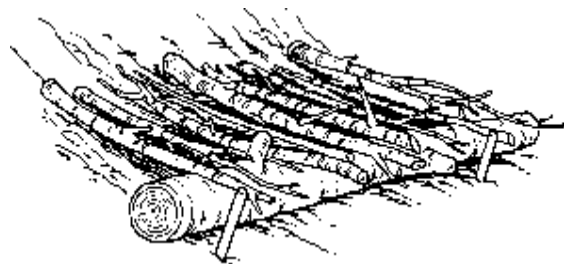
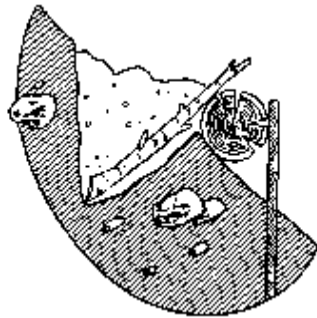

Source: Polster Environmental Services

- Live Cuttings  
Stakes of willow planted into exposed or eroding hill slopes and gully walls. Provide quick coverage of shrubs over an entire area and are effective alone or between modified brush layers.

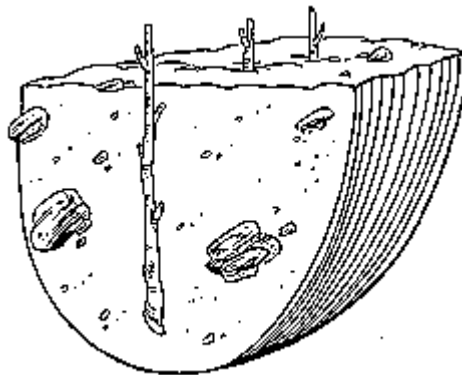

**Live Staking**

Source: Polster Environmental Services

- Live Gully Breaks  
Large wattle fences constructed across an eroding channel. Live gully breaks are designed to control the initiation of torrenting by reducing the effective gradient of the eroding channel.

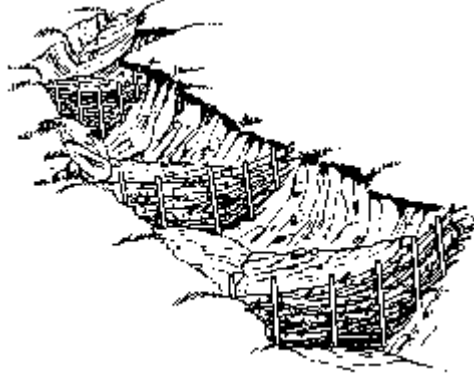

Source: Polster Environmental Services

- Interplanting Riprap  
Riprap is often used to protect stream banks and lakeshores. Live cuttings can be inter-planted in riprap to provide additional slope stability. Root growth below the riprap will improve soil strength and live vegetation will hide the rocks, providing a more natural look.

- Maintenance**
- Provide regular monitoring and maintenance, especially in the first year, to assure adequate plant survival.
  - Be aware that flood or drought conditions could impact the installation. Severe weather will reduce seedling survival and supplemental planting may be needed.

## Sources

Polster, D. (1998): **Introduction to Soil Bioengineering**; *British Columbia Ministry of Forests, Resource Tenure & Engineering Branch.*

Thomas G. F. (1997): **Bioengineering for Hillslope, Streambank and Lakeshore Erosion Control**; *Institute of Agriculture and Natural Resources, University of Nebraska-Lincoln*

Lewis, L., Salisbury S.L. and Hagen, S. (2000): **Soil Bioengineering for Upland Slope Stabilization**; *Washington State Department of Transportation, Research Project WA-RD 491.1.*



MAP CODE  
**BFZN**

# BUFFER ZONE

**USE**

Dust  
Erosion/Sediment  
Noise  
Stormwater  
Site Environmental  
Visual

## What

- ☛ A naturally vegetated or replanted area around the perimeter of the aggregate site, or adjacent to an environmentally sensitive area such as a stream, wetland or urban development.

## Purpose

- ☛ To minimize erosion, improve water quality, intercept dust, reduce noise, act as a wildlife corridor or enhance the visual appearance of the operation with trees, shrubs and plants.
- ☛ To reduce pollution into streams and reduce the flow and velocity of stormwater.
- ☛ To reduce and redirect wind. A buffer zone can reduce wind speeds on both the leeward and windward sides of an operation, which can reduce dust and noise being carried off-site.

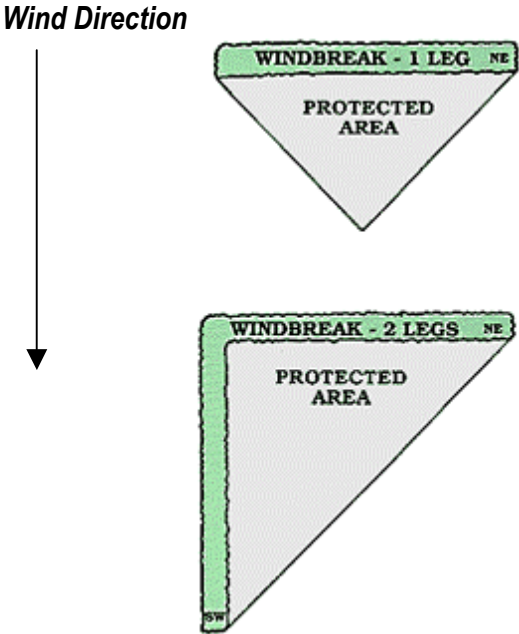



Source: University of Nebraska-Lincoln

## Where

- ☛ Around the site perimeter, along roadways or ridges, at the edge of any disturbed areas or adjacent to perennial streams or permanent water bodies.
- ☛ Alongside stormwater ditches to help reduce the amount of sediment and pollution in the water.
- ☛ Perimeter windbreaks of trees and shrubs can protect areas subject to erosion and dust generation due to wind, intercept noise and dust, and provide a visual barrier.

## Materials Equipment & Costs

-  Native trees, shrubs, seeds and fertilizer.
-  Backhoe for trees, shovels, labour.
-  Low to medium.

## Plans & Spec's

- A *Mines Act* permit may specify buffer widths.
- A windbreak density of 40% to 60% provides the greatest downwind area of protection, as well as excellent soil erosion control.
- If density is below 20%, the windbreak does not provide useful wind reduction. If density is above 80%, excessive leeward turbulence may reduce the windbreak effectiveness.
- Work around streams is regulated by statutes, regulations and guidelines administered by agencies such as Ministry of Water, Land and Air Protection and Fisheries and Oceans Canada (see Chapter 3).
- Where a natural buffer zone is not available, or the recommended zone width is not attainable, alternatives such as flow barriers, diversions, sediment traps, vegetative planting and silt fences may be used. Use of these alternatives may require government approval.
- Runoff from the disturbed areas should be allowed to spread out over the entire length of the buffer zone, and not channelled into a single discharge point within a buffer zone.

### Relative effectiveness of different vegetation types for providing specific buffer zone benefits

Benefit	Vegetation Type		
	Grass	Shrub	Tree
Stabilize bank erosion	Low	High	High
Filter sediment	High	Low	Low
<u>Filter nutrients, pesticides, microbes</u>			
• Sediment bound	High	Low	Low
• Soluble	Medium	Low	Medium
Aquatic habitat	Low	Medium	High
<u>Wildlife habitat</u>			
• Range/pasture/prairie wildlife	High	Medium	Low
• Forest wildlife	Low	Medium	High
Economic products	Medium	Low	Medium
Visual diversity	Low	Medium	High
Flood protection	Low	Medium	High
Dust control	Low	High	High
Noise reduction	Low	High	High

Source: [NRCS Planning & Design Manual](#), NRCS

**British Columbia shrub species which lend themselves to buffer zone application are:**

- |                           |                         |
|---------------------------|-------------------------|
| ⇒ Red Osier Dogwood       | ⇒ Indian Plum/Oso Berry |
| ⇒ Yellow Twig Dogwood     | ⇒ Sitka Alder           |
| ⇒ Beaked Hazelnut         | ⇒ Smooth Sumac          |
| ⇒ Wolf-willow/Silverberry | ⇒ Red Flowering Currant |
| ⇒ Ocean Spray             | ⇒ Nootka Rose           |
| ⇒ Twinberry               | ⇒ Snowberries           |
| ⇒ Tall Oregon Grape       | ⇒ Thimbleberry          |
| ⇒ California Lilac        | ⇒ Salmonberry           |
| ⇒ California Waxmyrtle    |                         |

- Maintenance**
- Little or none required except in the case of newly planted material, which will need adequate water (and perhaps fertilizer) until established.
  - Simple pruning of bushes and trees will produce a thicker, sturdier growth.

**Sources**

United States Department of Agriculture and Mississippi State University. (1999): **Riparian Buffer Zone**; in Water Related BMP's in the Landscape/Best Management Practices/Stream System Protection/C. Stream Bank Protection and Restoration/. *Watershed Science Institute United States Department of Agriculture and Mississippi State University*, <<http://abe.msstate.edu/csd/NRCS-BMPs/contents.htm>>, October 2001.

US Department of Agriculture, Natural Resources Conservation Service, (1994): **Planning & Design Manual for the Control of Erosion, Sediment, and Stormwater**.

Chilibeck, B., Chislett, G. and Norris, G. (1992): **Land Development Guidelines for the Protection of Aquatic Habitat**; *Department of Fisheries and Oceans, and Ministry of Environment, Lands and Parks*, URL <<http://www-heb.pac.dfo-mpo.gc.ca/english/publications/PDF/guidelines/ldg.PDF>>, June 2001.

Lincoln, J., Brandle, R., and Finch, S., **How Windbreaks Work**; Soil Conservation Service. University of Nebraska.

Lincoln, J., Brandle, R., Boehner, P. and Finch, S., **Windbreak Layout and Design**; Soil Conservation Service. University of Nebraska.

The Netherlands Ministry of Agriculture, Nature Management and Fisheries: **International Nature Management - Theme Study Series on innovative forest-related themes**; Wageningen, <http://www.minlnv.nl/inm/>, June 2000.

MAP CODE  
**CKDM**

# CHECK DAM

**USE**  
Erosion  
Stormwater  
Pollution

- What**
- ☛ A small temporary dam within a ditch, drainage, swale or channel.
  - ☛ Made of rocks, straw, logs, lumber or interlocking pre-cast concrete blocks.
- Purpose**
- ☛ To reduce the gradient of a ditch, slowing the water, lowering its ability to cause erosion, and allowing sediment to settle out.

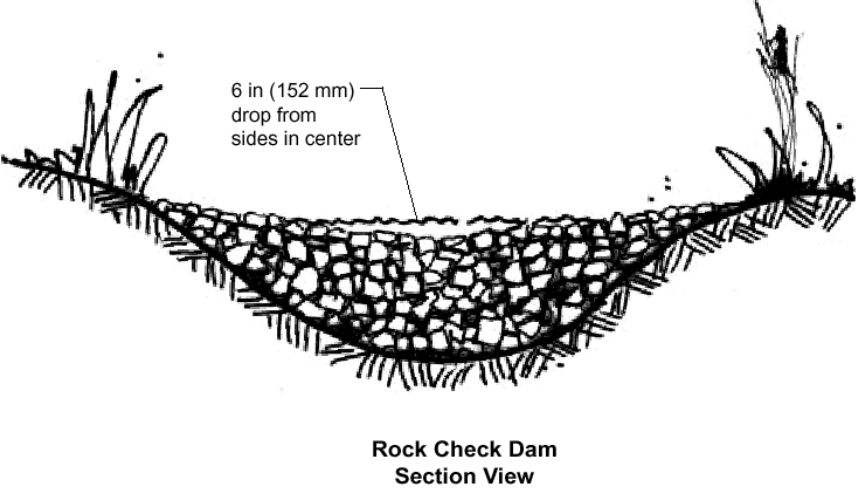

- Where**
- YES:** Ditches, channels, swales, constructed waterways, or conveyance structures.
  - NO:** Natural watercourses, any watercourses containing fish (whose passage might be blocked).
- Materials, Equipment & Costs**
- ☛ Rocks, (pea gravel up to 4 inches), sand bags, gabions (wire baskets of rocks), straw bales, logs, lumber, rubber tubes inflated with water or interlocking pre-cast concrete blocks.
  - ☛ Back hoe and labourer.
  - \$ Low.
- Plans & Specs**
- Maximum height should be about 0.6 metres, with a 0.25 metre notch or “V” in the centre to control the flow.
  - If using granular material, the check dam should have a triangular cross section, with slopes of 2 horizontal to 1 vertical or less.
  - Use non-erodible material (gravel, cobble, etc.) wherever water is concentrated (high velocity) or drops or flows rapidly over the structure.

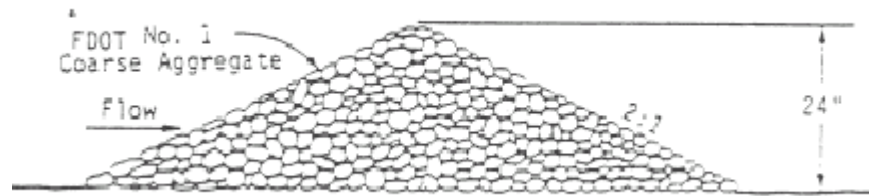

- Keep the top of the check dam about 0.3 metres below the top of the ditch or the ground elevation.
- If heavily sediment-laden flows are regularly expected, construct a sump immediately upstream of the check dam..
- Keystone the check dam materials up to 0.5 metres into the banks.
- Space the check dams so that the toe of the upstream check dam is the same elevation as the top of the downstream check dam (see figure).

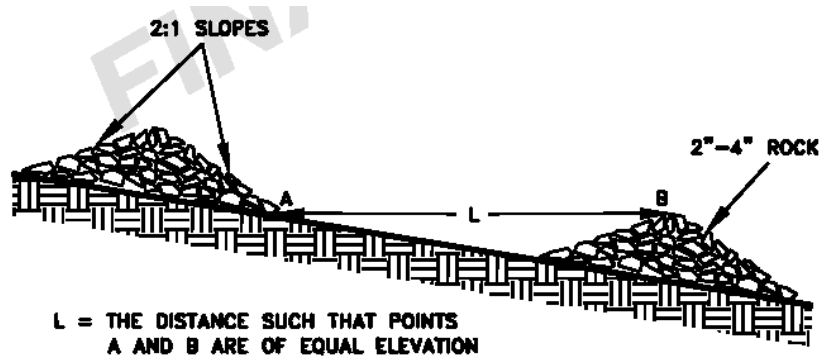

- When using non-granular materials such as boards or straw bales, place rip rap below the outfall to prevent erosion.
- Temporary check dams should be removed when no longer useful; when permanent channel linings, such as grass, have been established, for example.

## Options

### Filter Fabric

Filter fabric can be used under a rock or sandbag check dam to help prevent sediment from flowing through the dam. The bottom of the fabric should be anchored in a trench.

### Straw Bale Check Dam

Straw bales by themselves can be used in minor swales and ditches where the drainage area is less than 1 hectare, or where they will be pulled out in three months or less. The following diagram illustrates an effective use of straw bales in ordinary check dam installations.

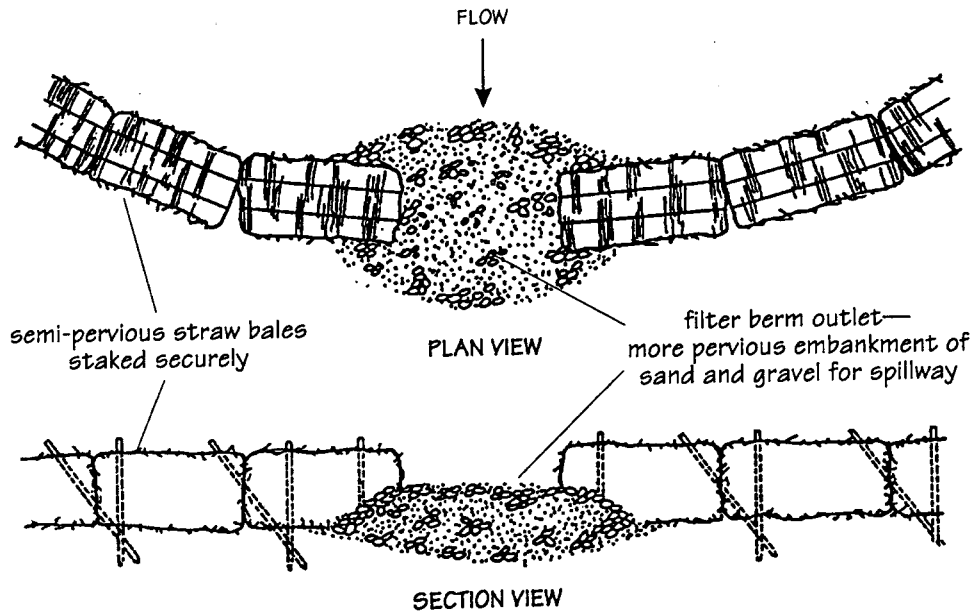

### Log Check Dam

Log check dams are composed of upright 4 to 6 inches (100-150 mm) boards or logs, embedded in the soil a minimum of one half metre. Log check dam may be composed of material salvaged from clearing operations.

## Maintenance

- Expect deposition above the dam and erosion around the sides and bottom. Areas of deposition should be cleaned out or repaired as necessary, and rip rapped if required.
- The check dam should be inspected during and after large storms or extended periods of rain for erosion around top edges, scour and infilling.
- Remove the sediment when it reaches half of the sump or dam height.

## Sources

Austin, L. (2001): **Construction Stormwater Pollution Prevention**; in Stormwater Management Manual for Western Washington, Volume II. *Washington State Department of Ecology*, Publication 9912, URL <<http://www.ecy.wa.gov/biblio/9912.htm>>, June 2001.

Norman, D.K., Wampler, P.J., Throop, A.H., Schnitzer, E.F. and Roloff, J.M. (1997): **Best Management Practices for Reclaiming Surface Mines in Washington and Oregon**; *Washington State Department of Natural Resources* Open File Report 96-2 and *Oregon Department of Geology and Mineral Industries* Open File Report O-96-2, page 2-18 to 2-19, URL <<http://www.wa.gov/dnr/htdocs/ger/pdf/bmp.pdf>> [PDF, 7.6 Mb], June 2001.

United States Department of Agriculture and Mississippi State University. (1999): **Check Dam**; in *Water Related BMP's in the Landscape/Best Management Practices/Water Runoff Control/C. Erosion Control. Watershed Science Institute United States Department of Agriculture and Mississippi State University*, <<http://abe.msstate.edu/csd/NRCS-BMPs/contents.html>>, October 2001.

# CONSTRUCTED WETLANDS

## What

- ☞ A modified natural or constructed shallow pond for the treatment of sediment-laden waters by wetland vegetation.

## Purpose

- ☞ Receives and temporarily holds sediment-laden waters to prevent downstream surface water pollution and to provide biological treatment to help meet acceptable turbidity/suspended solids (TDS) standards.



Photo: Sedun

## Where

- YES:** Where there is adequate space and where runoff may have moderately elevated total suspended solids, oils, pesticides, or nutrients that would be unsuitable for downstream receiving waters.

## Materials Equipment & Costs

- ☞ Suitable land area, liners (if required), inlet and overflow plumbing, fish trap, plants, native vegetation and soils.
- ✂ Earth moving equipment, labour.
- \$ High.

## Plans & Spec's

- The principle behind constructed wetlands is that incoming storm runoff displaces old water, which flows out of the pond. The new runoff is stored in a permanent pool in the pond until the next storm. This situation creates long detention times and high cleansing rates.
- The contributing drainage area to the wetland should be examined for potential contamination sources such as oil from roads and parking areas, yard spray

(pesticides), fertilizer residue, building or driveway washdowns, and runoff from stored materials, debris or bare soil areas.

- The soils at the wetland site should be sufficiently impermeable to be able to hold the turbid water for treatment and protection of the area groundwater.
- The constructed wetland should have sufficient detention volume to store storm runoff volume or the “first flush” of runoff which contains the majority of pollutants.
- The treatment rate is a direct function of the size of the pond: the larger the pond, the greater the treatment removal rate.
- A unique feature of wetlands is the presence of aquatic plants and algae that can remove significant amounts of soluble nutrients from stormwater, effectively reducing downstream algal growth.
- Install a fish guard/barrier or sediment trap to prevent fish from entering and inhabiting the wetland.

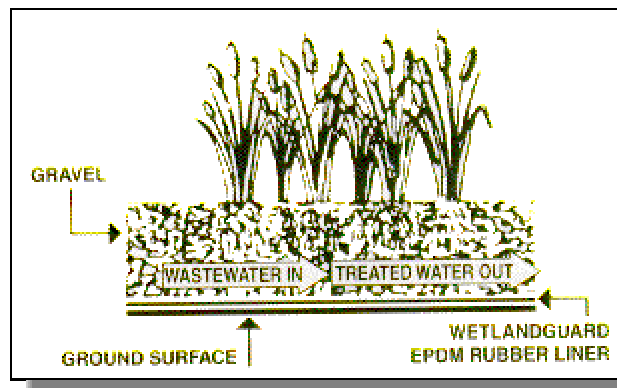

## Installation

- Consult with environmental professionals.

## Maintenance

- Clean out excessive sediment at intake.
- Remove excess plant build-up.
- Remove excessive siltation from the entire pond, one section at a time.

## Sources

National Conference on Urban Runoff Management: (1993) **Enhancing Urban Watershed Management at the Local, County and State Levels.**

United States Department of Agriculture, (1994) **Planning and Design Manual for the Control of Erosion, Sediment, and Stormwater, Best Management Practice Standards.**

National Risk Management Research Laboratory, **Constructed Wetlands Treatment of Municipal Wastewaters Manual**; U.S. Environmental Protection Agency, Office of Research and Development, EPA/625/R-99/010, URL

<http://www.epa.gov/ordntrmt/ORD/NRMRL/Pubs/2001/wetlands/625r99010.pdf>, November 2001.

Ministry of Water, Land and Air Protection. **Water Quality Website**; URL

<http://www.elp.gov.bc.ca/wat/wq/wqhome.html>, for Constructed Wetland BMP, go to [http://wlapwww.gov.bc.ca/wat/wq/NPS\\_web\\_page/BMP\\_Compedium/General/Aquatic\\_Habitat/Constructed.htm](http://wlapwww.gov.bc.ca/wat/wq/NPS_web_page/BMP_Compedium/General/Aquatic_Habitat/Constructed.htm).



MAP CODE  
DTCH

# DITCHES

USE

Erosion  
Sediment  
Stormwater  
Site Environmental

## What

- ☛ Open drainage works ranging from shallow, narrow, frequently dry ditches, to wide, deep, permanently wetted ditches.

## Purpose

- ☛ To capture and control stormwater and runoff, and to direct it off site. Ditches prevent storm water from collecting silt and can partially filter out potential pollutants, protecting downstream aquatic ecosystems.
- ☛ To divert stormwater and runoff around a site.
- ☛ To keep work areas as dry as possible, thereby maximizing production and reducing machine and tire wear.
- ☛ Also used to direct wash water to sediment ponds to receive treatment for reuse, load application or discharge.

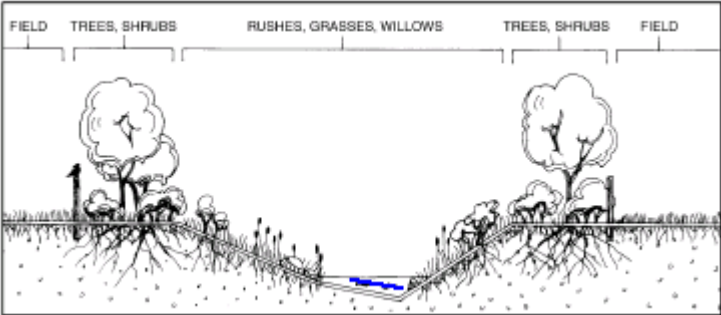

## Where

**YES:** Anywhere stormwater needs to be captured or conveyed. To effectively drain the active site, ditches should be located where stormwater would naturally collect and flow.

**NO:** Where natural watercourses convey water seasonally or perennially (i.e. do not channel natural watercourses).

## Materials Equipment & Costs

- ☛ Plants (shrubs, small trees) and grass seeds, geotextiles, gravel or rip rap for armouring, fish barrier.
- ☛ Backhoe, equipment operator, labour.
- ☛ Low to moderate.

## Plans & Spec's

### Design and Location

- Ditches should be sized to accommodate 110% of peak/storm flows. The sizing should allow for the volume of the vegetation planted in the ditch for erosion

control. By providing for this “over-capacity”, ditches will function effectively for a longer period and with reduced maintenance requirements and less risk of failure.

- Corners and outfalls should be armoured with rip rap or boulders.
- Ditches should have sufficient grade and capacity to carry the expected run-off, and should be designed and spaced to drain the entire site effectively.
- Permanent ditches should be constructed along the edges of the property; they may not be needed in some dry upland sites.
- With proper design, location and construction, ditches require less maintenance and are more economical over time.
- To minimize the creation of sediment:
  - construct and maintain ditches during dry periods;
  - provide vegetated swales or buffers to filter sediment and pollutants, and
  - provide filter berms or clean-outs to trap mobilized sediment and pollutants.
- Ditches should have barriers to prevent fish from entering and should drain into treatment structures.

## Vegetation & Planting

- Planting vegetation and a vegetated buffer strip alongside ditches can be highly beneficial, creating small wind breaks to reduce soil erosion and dust.
- Do not use pesticides close to ditches. A good rule of thumb is to maintain a minimum 10 metres pesticide-free zone along ditches.
- Vegetation growing on the bank of the ditch can help to remove sediment as surface run-off flows through it.

## Maintenance

- Regular emptying of clean-outs, especially at culvert inlets and outlets and sediment accumulation areas.
- It is best to work in or near ditches during dry weather.
- Look for areas of the ditch that consistently fill in over time and constrict water flow, usually at an obstruction or a sudden decrease in gradient. Clean out these sections first to see if improvements to water flow are adequate.
- If ditches and sumps are refilling with sediment on a chronic basis, erosion control measures upstream at the operation/site need to be reassessed and improved. Refer to BMPs.
- Check for erosion due to high flow rate.
- Armour as necessary.
- Add check dams if feasible.

## Sources

Fisheries and Oceans Canada. *Ditches, Fish and Fish Habitat*.

United States Department of Agriculture and Mississippi State University. (1999): **Diversion Channel**; in Water Related BMP's in the Landscape/Best Management Practices/Water Runoff Control/D. Water Volume Management/Diversion Channel. *Watershed Science Institute United States Department of Agriculture and Mississippi State University*, <[http://abe.msstate.edu/csd/NRCS-BMPs/pdf/water/volume/diversion\\_chan.pdf](http://abe.msstate.edu/csd/NRCS-BMPs/pdf/water/volume/diversion_chan.pdf)>, October 2001.

MAP CODE  
**DROP**

# DROP HEIGHT

**USE** Dust  
Noise

### What

☛ Reducing the distance material drops from conveyors and/or loading equipment.

### Purpose

- ☛ Minimizes and controls the amount of dust released into the atmosphere.
- ☛ Decreases noise generated by material impacting truck beds.
- ☛ Reduces the risk of operator injury due to the shaking that occurs when a load is dropped into a truck from a great height.



### Where

**YES:** Anywhere front-end loaders, excavators, dump trucks or conveyors drop material into hoppers or stockpiles.

### Materials, Equipment & Costs

- ☛ None.
- ☛ None.
- \$ Minimal.

### Procedures

- Monitor and minimize drop heights from loaders, excavators and conveyors.
- Use conveyors with adjustable heights.
- Locate drop zones behind a protective buffer or building in order to minimize wind velocity which can transport the dust released by the drop.

## What

- ☛ Rubber skirts around aggregate where it drops onto a stockpile or into a truck from a conveyor or hopper.

## Purpose

- ☛ To contain falling aggregate within a rubber skirt and shield it from exposure to wind, thereby reducing dust emissions, reducing cleanup costs and preventing material segregation.



Photo: Sedun (RMX Recycling Ltd., Victoria)

## Where

**YES:** In urban areas where dust emissions are a concern.

## Materials Equipment & Costs

- ☛ Rubber matting, sheeting or tarps.
- ✂ Tools for working with skirting material and hanging the skirt.
- \$ Variable depending upon skirting used.

## Plans & Spec's

- Attach skirt at the end of conveyors or below hoppers.
- The durability and flexibility of rubber matting or sheeting make them effective skirting materials.
- Tarps can also be used, but only temporarily, as the abrasion of aggregate will quickly rip and tear them.
- Serrating the bottom of the skirt will allow it to conform to the shape of stockpiles or loads within trucks.

## Maintenance

- Monitor the skirt for effective dust control.
- Inspect the skirt for tears, and repair as needed.

MAP CODE  
**EWNDW**

# ENVIRONMENTAL TIMING WINDOWS

**USE**

Site Environmental

## What

☛ A work schedule that does not conflict with critical life stages for fish and wildlife (e.g., spawning and nesting).

## Purpose

☛ To avoid harming fish or wildlife during one of their critical life stage activities.



Source: Alberta Land Conservation and Reclamation Council

## Where

**YES:** During activities that involve blasting, logging, stripping, clearing and grubbing work, especially any work that is done near streams or fish bearing waters. Ideally, work sites should be kept dry. If stormwater discharge is necessary, however, silt laden waters should not be introduced into natural waterways, particularly during sensitive periods for fish.

## Materials

☛ N/A

## Equipment

☛ N/A

## & Costs

\$ N/A

## Plans & Spec's

1. Consult with local Ministry of Water, Land and Air Protection or an "Environmental Atlas" for birds, fish or wildlife in the immediate location of the operation.
2. Contact the appropriate regulatory agency to determine the timing windows for critical life stage activities such as spawning, nesting or birthing.
3. Determine if any proposed activities will likely affect the critical life stages for fish, birds or mammals that live in the vicinity.
4. Sequence activities to avoid impacting those critical life stage activities.

## Effects of aggregate activities that impact fish & wildlife

Activity	Side Effect	Affects:
Clearing & Grubbing	Silt	Fish habitat
Clearing & Grubbing	De-forestation	Nesting, calving
Stormwater runoff	Silt	Fish habitat
Erosion	Silt	Fish habitat

- Key activities that should consider life stage activities in their scheduling are:
  - (a) Activities that expose significant amounts of soil;
  - (b) Major activities, such as reclamation works;
  - (c) Activities of lengthy duration.
- A key question to ask of all activities is: what measures should be in place to safeguard fish and wildlife values before the activity begins.

### Construction sequence for land clearing with scheduling considerations to reduce silt from entering natural watercourses and fish habitat.

Activity	Schedule Consideration
<b>1. Constructing initial access:</b> entrance, on-site routes, equipment parking areas.	<b>First land-disturbing activity:</b> stabilize bare soil areas immediately with gravel and temporary vegetation as excavation takes place.
<b>2. Installing sediment traps and barriers:</b> sediment fences, straw bale barriers and outlet protection.	<b>Install principal basins after mine site is accessed:</b> install additional traps and barriers as needed during excavating.
<b>3. Installing ditches &amp; runoff control:</b> ditches, water bars, check dams, inlet and outlet protection, slope drains.	<b>Install key control measures after principal sediment traps and before excavating:</b> install additional runoff-control measures during excavating.
<b>4. Land clearing and grading:</b> site preparation - cutting, filling and grading, sediment basins, barriers, diversions, drains, surface roughening.	<b>Begin major clearing and excavating after principal sediment and key runoff-control measures are installed:</b> clear borrow and disposal areas only as needed. Install additional control measures as excavation progresses. Mark trees and buffer areas for preservation.

- In planning clearing and grubbing work, it may be helpful to outline the sequence of activities and list any erosion control and sediment traps that should be in place before the next stage of the clearing begins. This list can provide a logical order to schedule work.
- Schedules will vary due to weather and other unpredictable factors.

## Installation

- Site access is normally the first land-disturbing activity. Exercise care not to damage valuable trees or disturb designated buffer zones.
- Install principal sediment basins before any major site clearing and grubbing takes place. Erect additional sediment traps and sediment fences to keep sediment contained on-site at appropriate locations.

- Locate key runoff-control measures to divert water from planned undisturbed areas out of the traps and sediment-laden water into the settling ponds or sediment basins.
- Install diversions above areas to be disturbed prior to work and install additional runoff-control measures as work takes place.
- Install the main ditches with inlet and outlet protection devices early, and use them to convey storm runoff through the site.

**Typical stabilization considerations for a general aggregate development sequence**

Aggregate Development Activity	Schedule Consideration
<b>1. Pre-development surface stabilization:</b> temporary and permanent seeding, mulching, sodding, riprap.	Apply temporary or permanent stabilization measures immediately on the disturbed areas where work is delayed or complete.
<b>2. Development:</b> buildings, utilities, paving.	Install necessary erosion and sedimentation control practices as work takes place.
<b>3. Landscaping and final stabilization:</b> topsoiling, trees and shrubs, permanent seeding, mulching, sodding, riprap.	Last phase - Stabilize all open areas, including borrow and spoil areas. Remove and stabilize all temporary control measures.

- Maintenance**
- Follow the schedule. When changes in mining activities are needed, amend the schedule in advance to maintain environmental timeframe control.
  - Following a work timeframe should help keep field personnel aware of the environment around them. Orderly modification assures coordination of work targets while ensuring basic needs of wildlife and the environment are met.



**Sources**

United States Department of Agriculture. (1994): **Planning and Design Manual for the Control of Erosion, Sediment, and Stormwater, Best Management Practice Standards.**

British Columbia Ministry of Water, Land and Air Protection. (2001): **Environmental Objectives, Best Management Practices and Requirements for Land Developments;** BC Environment, Vancouver Island Region, URL [http://wlapwww.gov.bc.ca/vir/pa/bmp\\_dev1.htm](http://wlapwww.gov.bc.ca/vir/pa/bmp_dev1.htm), October 2001.

MAP CODE  
EQUIP

# EQUIPMENT SELECTION

**USE**  
Dust  
Noise  
Emergency  
Spill Response

## What

- ☛ Selecting equipment based on its energy consumption, noise output, exhaust configuration, compatibility with other equipment on site, and compatibility with approved mine plan.

## Purpose

- ☛ To reduce energy consumption, noise and dust emissions, and the costs of replacement parts for each piece of equipment purchased.



OR



## Where

**YES:** All fixed and mobile plants.

## Materials Equipment & Costs

- ☛ N/A
- ✂ N/A
- \$ Varies. Equipment with noise and dust control options may increase costs.

## Plans & Spec's

- Consider drive-by noise.
- Consider upswept exhaust. Exhaust directed to the ground can create dust.
- Can the direction of the exhaust be rotated so that during peak outputs, such as power lifting from a stockpile, the noise of the exhaust is directed away from a neighbour?
- Is the equipment designed for ease of capture and proper disposal of used fluids and waste materials such as oils, coolants, filters, batteries and tires?
- Select equipment that produces low levels of emissions. Some advanced engines are able to produce greater torque at lower revolutions per minute (RPMs) than conventional engines, while creating fewer emissions.
- Where applicable, use biodegradable hydraulic fluids. These products are comparable to conventional oils in price, use the same seals and filters, are non-toxic, and can mix with mineral oil to allow for changes in the field.
- Does the equipment come with its own spill kit?
- Does the loader capacity match truck capacity?



- Does the loader (crusher, wash plant, etc.) have the necessary capacity to meet production goals within the hours of operation allowed by the local government?
- Does the wash plant recover all saleable material in order to reduce sediment going to the settling pond?
- Does an excavator provide greater reach to permit higher benches?
- Would larger trucks result in fewer trips to reduce traffic impacts?
- Would smaller trucks result in less noise, dust and vibration generation?

## **Maintenance**

- Establish a regular maintenance schedule according to manufacturer's guidelines.

MAP CODE  
ECB

# EROSION CONTROL BLANKET

**USE**  
Erosion  
Sediment  
Stormwater

## What

- ☛ A temporary protective blanket laid on top of bare soil vulnerable to erosion, commonly made of mulch, wood fibre or synthetics.

## Purpose

- ☛ Placed onto prepared, seeded soils to prevent washing away of the seed and erosion of the prepared seedbed. After the vegetation grows, the blanket degrades over time until only the vegetation is left in place. Once established, the vegetation provides permanent erosion control.
- ☛ Can be used on steep slopes where severe erosion control problems are anticipated.

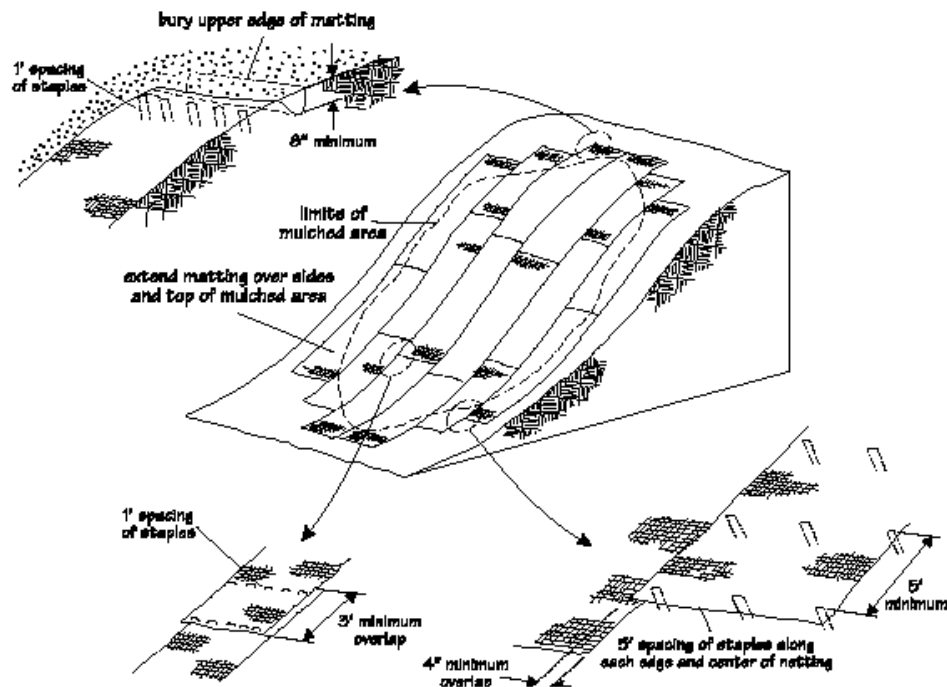



Source: Idaho Department of Lands, 1992.

## Erosion Control Blanket Installation

## Where

- YES:** Erosion control blankets are superior to hydroseeding when the growing season is short and plants cannot stabilize the slope quickly, when at high altitudes or where major storms are a frequent occurrence.

## Materials Equipment & Costs

-  Mulch, wood fibre, synthetics or combinations, and staples, stakes or anchors.
-  Hand tools, labour.
-  Medium to high.

## Plans & Spec's

- Applying erosion control blankets over large areas can be prohibitively expensive. However, small applications in areas that are especially steep and/or prone to erosion can be very effective in conjunction with cheaper methods such as hydro-mulching and/or hay mulch and netting.
- The effectiveness of jute netting and mulch fabrics is greatly reduced if rills and gullies form beneath these fabrics. Therefore, proper anchoring and ground preparation are essential.
- To further control the amount of stormwater that may flow over an area, consider installing a diversion ditch at the top of the slope.

## Installation

- Care should be taken to anchor edges (particularly on the up-slope side) and overlap joining sections to ensure adequate protection.
- Follow manufacturer's instructions.

## Maintenance

- Close inspection after storms and major runoff occurrences is essential, as erosion control blankets will often mask slope failures from all but the closest scrutiny until erosion is so far along that the slope can no longer be effectively treated with spot methods.

## Sources

United States Department of Agriculture and Mississippi State University. (1999): **Erosion Control Blanket**; in Water Related BMP's in the Landscape/Best Management Practices/Water Runoff Control/C. Erosion Control. *Watershed Science Institute United States Department of Agriculture and Mississippi State University*, <<http://abe.msstate.edu/csd/NRCS-BMPs/contents.html>>, October 2001.

Austin, L. (2001): **Construction Stormwater Pollution Prevention**; Stormwater Management Manual for Western Washington, Volume II. *Washington State Department of Ecology*, page 73, Publication 9912, URL <<http://www.ecy.wa.gov/biblio/9912.htm>>, June 2001.

Norman, D.K., Wampler, P.J., Throop, A.H., Schnitzer, E.F. and Roloff, J.M. (1997): **Best Management Practices for Reclaiming Surface Mines in Washington and Oregon**; *Washington State Department of Natural Resources Open File Report 96-2 and Oregon Department of Geology and Mineral Industries Open File Report O-96-2*, page 2-15, URL <<http://www.wa.gov/dnr/htdocs/ger/pdf/bmp.pdf>> [PDF, 7.6Mb], June 2001.

# FENCES

**What**

☛ A man-made or natural barrier.

**Purpose**

- ☛ Can reduce the amount of noise and dust leaving the site, create a visual barrier, and prevent trespassing.
- ☛ To protect trespassers or livestock from potential hazards within an aggregate site by physically preventing or hindering entry.
- ☛ To minimize liability in the event of injury or death as a result of unauthorized entry.



**Where**

- YES:** Around the perimeter of the aggregate operation (for security), at any point on the perimeter (to prevent dust or noise from reaching off-site receptors), at any sight line between the mine and off-site receptors (as a visual barrier), between any loud mining activity (i.e., crushing) and any possible receptor, or beside or around a dust-generating activity.
- NO:** There may be some limitation to the use of fences as a means of preventing trespass in areas with heavy snowfall.

**Materials  
Equipment  
& Costs**

- ✂ 18 gauge steel, chain link, barbed wire, pre-cast concrete, rock, hedges, fence stakes or posts, staples, nails or wire, etc.
- ✂ Dependent on type and function of the fence.
- \$ Low to high depending on height, materials and design.

Noise

**Plans &  
Spec's**

- There are many fencing options available to block or minimize noise (e.g., chain link, 18 gauge steel, barbed wire, pre-cast concrete, rock).
- To be effective, the fence needs to be high enough to block the noise generating activity from the line of sight of any receptor, and long enough to prevent noise from “leaking” around the ends.
- Used conveyor belts hung on a sturdy frame have long been used as a very effective noise barrier/fence.

- Fencing materials should be either flexible enough to absorb noise, or rigid enough to reflect it.

#### Dust

- Solid fences and vegetative screens have both been found to be effective.
- A vegetative screen has the advantages of enhancing the appearance of the mine, and requiring no maintenance once established.
- Existing vegetation can be used as a screen by locating dust generating activities, such as a haul road, on the down wind side of the vegetation.

#### Risk Management

- Barbed wire is the most cost effective fencing for deterring unauthorized entry.
- Construct the fence high enough that it cannot be easily scaled, and string the wire in loose double loops for entanglement.
- Post signs every 15 to 30 metres, and ensure that at least one sign is visible from any position at the fence. See also Signage BMP.

#### Visual

- A thick screen of trees and native vegetation is a visually appealing fence and has the added ability to screen noise and dust.
- Position the screen or fence between on-site features such as workings, equipment, buildings or the excavation face, and any off-site receptors.

## Options

- Maintenance**
- Regular inspections should be conducted, particularly before and after hunting seasons. Repair or replace damaged or missing signs.
  - Dependent on the type of fence. Solid wood fences may require powerwashing on a regular basis as dust or dirt accumulates.

## Sources

Mah, K.L. (1987): **Security and Safety of Aggregate Pits**; *Alberta Transportation*, Aggregate Services, Materials Engineering Branch, Aggregates Bulletin #6.

# FRENCH DRAINS

**What**      ➔ A hole or trench filled with coarse aggregate. Also called a Dry Well.

**Purpose**    ➔ To hold collected water until it percolates into the ground.

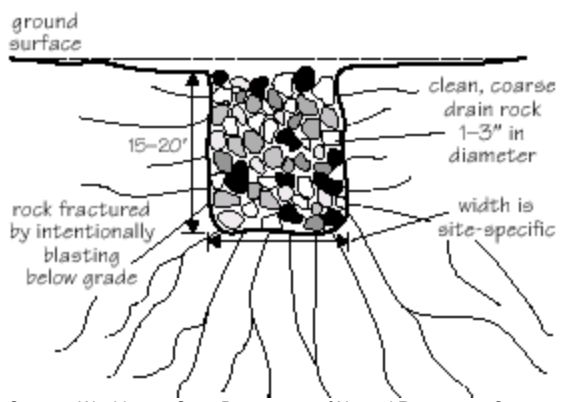

Source: Washington State Department of Natural Resources, Oregon Department of Geology and Mineral Industries.

**Details French Drain construction.**

**Where**    **YES:** Wherever stormwater cannot be drained off (e.g., around buildings), volumes are small, or natural infiltration is poor.

**Materials, Equipment & Costs**

- ➔ Coarse aggregate, filter fabric, optional blasting explosives to fracture quarry rock.
- ⚡ Backhoe or excavator, hand shovel, labour.
- \$ Low.

**Plans & Specs**

- Flatter areas are preferable.
- Because there is no outlet for water, French drains should be located where stormwater will naturally accumulate.
- Ditches and grading can also be used to direct stormwater runoff to the French drains.
- French drains should not be used where oil and grease are present to contaminate the ground water.

**Installation**

- Excavate a hole or trench to the maximum reach of the equipment used: the deeper the better.

- Line the excavation with filter fabric. For lining the walls, drape the filter fabric over the edge while backfilling. It can be secured by holding the top in place prior to draping it into the hole, by stapling it to the walls, or with boards fastened to the walls.
- Fill the bottom of the well with clean and washed pea gravel to form the base. Clean coarse aggregate can be used to fill the excavation to within 15 cm of the top. Cap the excavation with a 15 cm layer of pea gravel to act as a filter.
- Percolation rates should not be less than 15 cm per hour and can be tested the same way as septic fields.
- To avoid compacting the subsoil, use equipment with tracks or oversized tires.

## Maintenance

- Maintenance is typically limited to periodic replacement of the fill with clean rock.
- Periodic inspection is required to ensure that the stone fill is level to the ground surface and that the filter fabric, if used, has not become clogged with material.
- A larger well will function for a longer period before requiring maintenance.

## Sources

United States Department of Agriculture and Mississippi State University. (1999): **Dry Well**; in Water Related BMP's in the Landscape/Best Management Practices/Water Runoff Control/D. Water Volume Management,. *Watershed Science Institute United States Department of Agriculture and Mississippi State University*, <<http://abe.msstate.edu/csd/NRCS-BMPs/contents.html>>, October 2001.

Norman, D.K., Wampler, P.J., Throop, A.H., Schnitzer, E.F. and Roloff, J.M. (1997): **Best Management Practices for Reclaiming Surface Mines in Washington and Oregon**; *Washington State Department of Natural Resources Open File Report 96-2* and *Oregon Department of Geology and Mineral Industries Open File Report O-96-2*, page 2-20, URL <<http://www.wa.gov/dnr/htdocs/ger/pdf/bmp.pdf>> [PDF, 7.6Mb], June 2001.

MAP CODE  
**GRDG**

# GRADING

**USE** Erosion  
Sediment  
Stormwater

## What

➔ Reshaping the ground surface to prepare the site for processing equipment, stock pile areas, etc., and for post extraction reclamation.

## Purpose

- ➔ To provide suitable topography for post-mining land uses.
- ➔ To facilitate equipment operation and stockpiling.
- ➔ To control surface runoff.
- ➔ To minimize soil erosion and sedimentation both during and after development of the site or aggregate extraction.



Source: City of Los Angeles

## Where

**YES:** Wherever re-contouring is necessary for operational activities, site development, operation of sediment control practices, stockpiling, or to achieve land forms required for reclamation.

## Materials Equipment & Costs

- 🚛 None.
- ✂ Grader, scraper, or bulldozer with blade.
- \$ Low.

## Plans & Spec's

- Careful shaping of an aggregate site for operations and for post-reclamation activities reduces the potential for erosion and the cost of installing erosion and sediment control measures.
- Before grading begins, decisions must be made on the steepness of cut-and-fill slopes and how they will be protected from runoff, stabilized and maintained. A



grading plan can establish drainage areas, direct drainage patterns and affect runoff velocities.

- A grading plan can form the basis of an erosion and sediment control plan. Key considerations that affect erosion and sediment control include deciding which slopes are to be graded, when the work will start and stop, the slope angle, the length of finished grades, where and how excess material will be stored or disposed of, and where borrow material will be needed. Early completion of grading work allows for prompt topsoiling and vegetation for erosion control and eliminates temporary seeding expense.
- Undisturbed temporary and permanent buffer zones may provide an effective and low-cost erosion control measure for adjacent grading work.
- Intercept and redirect stormwater to avoid flows on newly graded slopes.
- Use slope breaks, such as diversions or benches, as appropriate, to reduce the length of a cut or fill slope, limit sheet and rill erosion and prevent gullyng. A spacing guide is shown below.

### Spacing guide for slope breaks

	Slope *	Slope Break Spacing (metres)
<b>Steep Slopes</b>	2:1 (50%)	6.0
	3:1 (33%)	11.0
	4:1 (25%)	14.0
<b>Long Slopes</b>	15-25%	15.0
	10-15%	24.0
	6-10%	38.0
	3-6%	61.0
	<3%	91.0
* 100% slope = 1:1 = 45°		

- Stabilize all graded areas with hydroseeding, vegetation, crushed stone, riprap or other appropriate ground cover as soon as grading is completed. Use mulch or straw to temporarily stabilize areas where final grading must be delayed.
- For grass and legume cover, finished slopes should not be steeper than 2:1. Slopes to be maintained by tractor or other equipment should not be steeper than 3:1.
- Roughen the surface of all slopes during the grading to retain water, increase infiltration and facilitate vegetation. Running a tracked vehicle up and down the slope leaves divots perpendicular to the slope length that can roughen the hill slope. Do not drive the tracked vehicle across the contour of the slope, as that will leave divots that channel water down slope.
- In areas with high water tables, install underground drainage to prevent seepage, and thus keep the surface dry.

- Fill should not be placed adjacent to a channel bank, where it can create bank instability and failure, or result in deposition of sediment downstream. Also avoid placing fill in places where it will block or limit natural flooding.
- Provide stable channels and floodways to convey all runoff from the developed area to an adequate outlet without causing increased erosion or off-site sedimentation.

## **Installation**

- Construct and maintain all erosion and sediment control practices and measures in accordance with sediment control planning.
- Timing of grading should account for the conditions for revegetating the site after the machine work is completed. For example, grading should not be done during an extreme rainfall event.
- Scarify the surface to a minimum depth of 8 centimetres before placing topsoil.
- Excessively compacted areas should be thoroughly ripped/subsoiled to facilitate drainage and root growth.
- Keep diversions and other water conveyance measures free of sediment until other vegetation is established.
- Permanently stabilize all graded areas immediately after final grading is completed.

## **Maintenance**

- Periodically check all graded areas and supporting erosion and sediment control measures, especially after heavy rainfalls.
- Remove excess sediment from diversions and other water-disposal structures.
- If washouts or breaks occur, repair them immediately.

## **Sources**

National Conference on Urban Runoff Management (1993): **Training for Construction Site Erosion Control and Stormwater Facility Inspection**; Enhancing Urban Watershed Management at the Local, County and State Levels.

MAP CODE  
ROAD

# HAUL ROADS

**USE**  
Dust  
Noise  
Sediment  
Stormwater

## What

☛ System of roads within an aggregate mining operation.

## Purpose

- ☛ To facilitate safe and efficient operation of mobile equipment while minimizing environmental impacts.
- ☛ When well-designed and constructed, haul roads can make the aggregate operation safer, more productive, and cause less wear and tear on equipment.

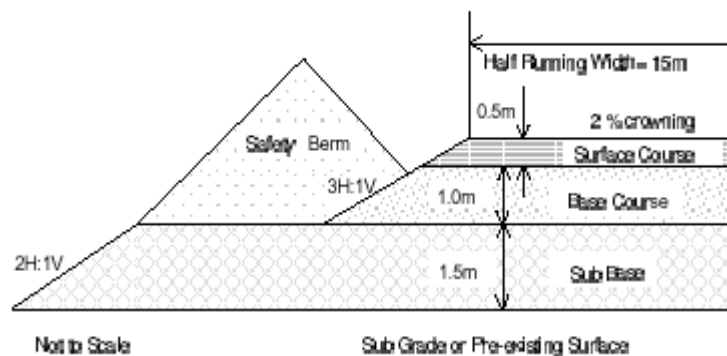

Typical haul road cross-section.

Source: University of Alberta

## Where

**YES:** All aggregate operations.

## Materials Equipment & Costs

- ☛ Mine waste, gravel, overburden, crushed stone, asphalt or concrete.
- ☛ Bulldozer, excavator, scraper, dump truck.
- \$ Varies.

## Plans & Spec's

- Keep frequently used haul roads and other heavy traffic areas dry by elevating the surface to facilitate runoff.
- Dryer roads cause less wear and tear on tires and equipment and create less sediment-laden water that will require treatment.
- Make sure roads are well capped with durable rock of appropriate size.
- Road widths are usually designed to be 3 times the width of the largest haul truck (for 2 way traffic) with extra width employed on the curves. (Refer to [HSRC 6.8](#))
- Road shoulder barriers/berms should be  $\frac{3}{4}$  of the height of the largest tire on any vehicle hauling on the road.

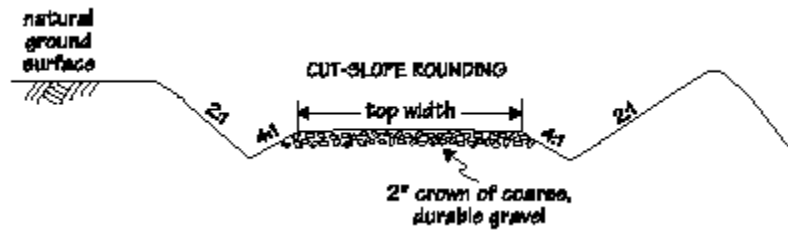

### Profile of elevated haul road on side hill.

Source: Washington State Department of Natural Resources, Oregon  
Department of Geology and Mineral Industries

- Banking of curves (super-elevations) and their transitions are designed to minimize the centrifugal forces on the haul truck while negotiating the curve. Super-elevations should be in the range of 4% to 6%, depending on the curve radius and equipment speed.
- In the design of both horizontal and vertical curves, line-of-sight and stopping distance are key criteria. Design curves so that the line-of-sight of the driver is equal to or longer than the stopping distance of the loaded haul truck.

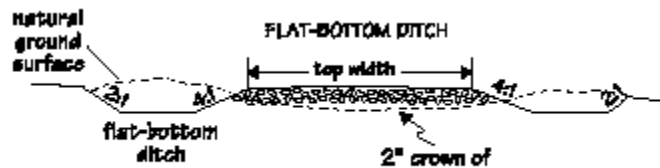

### Profile of elevated haul road on flat ground.

Source: Washington State Department of Natural Resources, Oregon  
Department of Geology and Mineral Industries

- Grades usually vary from -20% to +20%. Grades over 10%, however, are used only for short distances in temporary situations. The preferred maximum grade is usually 8%.
- Sharp horizontal curves should not be designed at the top or bottom of hills.
- Intersections should be located at flat, straight alignments of the haul road.
- Road surface cross-slopes should be approximately 1:25 (4%) for good drainage.
- Curve radii should always exceed the minimum turning radius of the equipment.
- Provide runaway lanes for grades in excess of 5%.

### ECONOMICS

When considering the quality of the road to construct, the most important items are:

- Life of road
- Use of road (amount of production over the road)
- Location of road (is it permanent or does it have to be removed?)

## Classification of Haul Roads by lifespan

<b>Temporary Roads</b>	<ul style="list-style-type: none"> <li>• short life</li> <li>• minimum thickness</li> <li>• low specification material</li> <li>• inexpensive to build</li> <li>• used mainly for shovel or dump access</li> </ul>
<b>Semi-Permanent Roads</b>	<ul style="list-style-type: none"> <li>• medium life</li> <li>• engineered to desired thickness</li> <li>• high specification material</li> <li>• relatively expensive to build</li> <li>• used for main haul roads in pits and out-of-pit hauls in non-final pit walls</li> </ul>
<b>Permanent Haul Roads</b>	<ul style="list-style-type: none"> <li>• long life</li> <li>• engineered to ultimate thickness</li> <li>• high specification material (may even be paved)</li> <li>• expensive to build</li> <li>• used for final out-of-pit haul roads.</li> </ul>

### DESIGN

- A haul road consists of four distinct layers:

#### Sub-grade

Sub-grade made of hard, sound rock or dense, compact gravel, may not require fill as haul trucks can travel on the sub-grade surface. If the sub-grade lacks the required bearing capacity, then it needs to be altered through suitable measures such as compaction.

#### Sub-base

Run of mine and coarse rock usually make up this layer. The sub-base provides structural strength to the road and can also prevent intrusion of the sub-grade soil into the base course and vice-versa, minimizing the effect of frost and accumulation of water in the road structure.

#### Base course

Usually high quality material with suitable size fractions is used for the construction of this layer. As the base course is the main source of the structural strength of the road, specifications of strength, plasticity and gradation are generally more stringent than for the other layers.

#### Surface

Generally constructed with appropriately sized gravel closely controlled grading to avoid dust problems while maintaining the binding characteristics of the material. Apart from providing a smooth riding surface, it distributes the load over a larger area, thus reducing stress.

- Maintenance**
- Establish a regular grading program that will minimize erosion, sediment build-up, noise and dust.
  - Ensure that potholes, washboarding and frost heaving are repaired immediately to minimize noise, dust and equipment wear.

## Sources

- Spray water, calcium chloride or other approved dust suppressant on the road surface.
- Roads may also require scarifying, sanding and resurfacing.

Ministry of Employment and Investment. (1997): **Health, Safety and Reclamation Code for Mines in British Columbia** Section 6.8.

British Columbia Ministry of Energy and Mines. (1997): **Health, Safety and Reclamation Code for Mines in British Columbia** Section 6-8; Mines Branch, URL

<<http://www.em.gov.bc.ca/Mining/Healsafe/hsrecode1.htm>>, October 2001.

Tannant, D. and Regensburg, B. (2000): **Guidelines for Mine Haul Road Design**; *University of Alberta, School of Mining and Petroleum Engineering*.

Norman, D.K., Wampler, P.J., Throop, A.H., Schnitzer, E.F. and Roloff, J.M. (1997): **Best Management Practices for Reclaiming Surface Mines in Washington and Oregon**; *Washington State Department of Natural Resources* Open File Report 96-2 and *Oregon Department of Geology and Mineral Industries* Open File Report O-96-2, page 2-18 to 2-19, URL <<http://www.wa.gov/dnr/htdocs/ger/pdf/bmp.pdf>> [PDF, 7.6Mb], June 2001.

# LIGHTING MANAGEMENT

## What

☛ The planning and installation of a lighting system that facilitates safe and secure operations, while minimizing offsite visual nuisance.

## Purpose

☛ To help ensure a safe working environment, extend hours of operation, illuminate on-site hazards for staff and visitors, and provide security to the site after hours.



## Where

**YES:** Entrance/exit, work faces, haul roads, stockpiles, buildings, equipment, vehicles.  
**NO :** Wherever it may spill, glare or reflect off-site.

## Materials Equipment & Costs

☛ Worklights, headlights, back-up lights, signals, spotlights, warning lights, hazardous area lighting, emergency lights, floodlights, wiring, fixtures.  
✂ Electrician and appropriate wire and tools, equipment necessary for raising poles or light standards, labour.  
\$ Low to medium.

## Plans & Spec's

- Where lighting is installed, ensure that it is directed downward to minimize off-site spill and glare. Balance safety and security with concerns of neighbours.
- Lights positioned so that they are shielded by buildings or permanent plant facilities may be less visible from the surrounding countryside and pose less of an annoyance to neighbours.
- Lighting is often installed for security and risk management purposes.
- Mount lighting below the roof height of buildings and perimeter fencing and direct the light downwards.
- Keep lighting of road junctions and site entrances to the minimum required for safety purposes.

- Light poles, stands and columns will blend in with the surrounding landscape if painted a similar colour (e.g., a dark colour if the light poles are set against a backdrop of vegetation). Trees and hedgerows may also help to 'contain' the light.

## **Maintenance**

- Regular inspection is required to ensure burned out tubes and bulbs are replaced and broken fixtures are repaired.

## **Sources**

Cole, L., Smith, P., Wright, J. and Clough, R. (1999): **Controlling the Environmental Effects of Recycled and Secondary Production Good Practice Guidance**; *United Kingdom Department of the Environment, Transportation and the Regions*, URL <<http://www.planning.detr.gov.uk/recycled/practice/index.htm>>, June 2001.



MAP CODE  
MCOR

# MATERIAL CORRALS

**USE** Erosion  
Stormwater

## What

☛ Three-sided storage bays made from interlocking pre-cast concrete blocks.

## Purpose

☛ To keep specialized products and material clean and segregated, especially at tight locations.



Photo: Sedun, RMX Recycling, Victoria B.C.

## Where

**YES:** In areas of limited space, and where product purity specifications are strict.

## Materials

☛ Pre-cast concrete blocks.

## Equipment

☛ Excavator or front-end loaders, broom, pry bars.

## & Costs

\$ Depends on size of corral and price of blocks.

## Plans & Spec's

- Follow manufacturer's specifications and instructions for design and installation of walls.
- Pre-cast concrete block walls require a solid, level foundation, with approximately 15 centimetre of granular material for drainage.
- Rolled filter cloth placed between blocks will help stop fine-grained products from migrating through the corral walls.
- Poured concrete floors or pre-cast concrete slabs can protect products from contamination by surface materials.

- Camber (arch) the corral floor to facilitate drainage. In exceptionally wet areas, stormwater drainage pipes may have to be laid adjacent to corral walls.
- Walls of three to four layers of blocks are usually sufficient. For higher walls, a qualified engineer should be consulted.
- If backfilling behind the back wall, install sufficient drainage pipe surrounded by drain rock.

## **Installation**

- Prepare the site by levelling the area, cambering the corral floor, compacting any fill material, and preparing any drainage trenches that will not be accessible after construction of the walls.
- Prepare a level and compacted gravel base for the first layer of blocks.
- Lay down four to six base layer blocks.
- Sweep the top of each layer before subsequent layers are laid.
- Place rolled-up filter fabric between blocks on all sides. Duct tape can be used to hold the filter fabric during assembly.
- Lay the second and subsequent layers in a staggered manner, to ensure they fit.

## **Maintenance**

- Inspect for material migrating through wall.
- Where excessive settling has occurred, sections of the wall may have to be re-laid.
- Pressure wash and apply surface treatments as required (algae growth, changed product, etc.).

United Lock-Block™ Ltd. URL <<http://unitedlockblock.com/>>, August 2001.

## **Sources:**

# OIL/WATER SEPARATORS

**USE**

**Emergency Spill  
Risk Management  
Stormwater  
Waste**

**What**

☛ A pond or tank that separates petroleum products from water using the difference in liquid density.

**Purpose**

☛ To remove petroleum products prior to release or reuse of water.

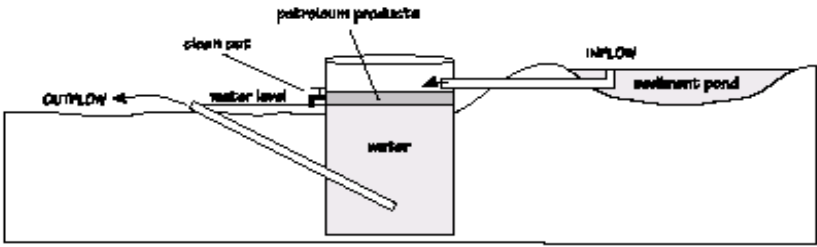

Source: WSDNR, ODGMI

This system uses a clean-out spigot to remove the oil as it floats atop the water.

**Where**

**YES:** Anywhere hydrocarbon-contaminated water can be collected, or prior to release into the environment.

**Materials  
Equipment  
& Costs**

- ☛ A concrete or metal tank set up as an oil/water separator.
- ✂ Equipment to move tank, hand tools to install, labour.
- \$ Moderate to high.

**Plans &  
Spec's**

- Size and type will not be the same for every operation.
- As a rule of thumb, the tank or collection area should have at least 1.85 square metres of surface area per 1000 square metres of drainage area to allow the petroleum to remain on the surface,.
- The water velocity and volume must be low enough to prevent oil/water mixing or overspillage.
- The majority of settleable solids must be removed from the stormwater stream before it reaches the oil/water separator or the separator will quickly become filled with sediment.

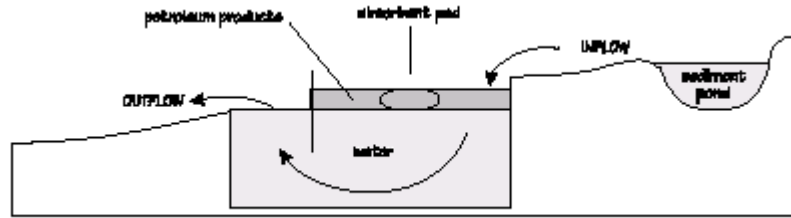

Source: WSDNR, ODGMI

This system uses an absorbent pad to soak up the oil.

## Maintenance

- Scheduled maintenance should be performed to provide for periodic removal of debris and to ensure that the devices are operating efficiently.
- Surface facilities should undergo a drive-by inspection at least weekly and after any rain totalling 13 millimetres or more in 24 hours.
- Oil and solids should be removed frequently, including at the beginning and end of the main runoff season. The waste must be disposed of as specified by regulations.
- The effluent shutoff valve should be operational for closure during cleaning.

## Sources

Chilibeck, B., Chislett, G. and Norris, G. (1992): **Land Development Guidelines for the Protection of Aquatic Habitat**; Department of Fisheries and Oceans, and Ministry of Environment, Lands and Parks, URL <<http://www-heb.pac.dfo-mpo.gc.ca/english/publications/PDF/guidelines/lhg.PDF>>, June 2001.

Ciuba, S. and Austin, L. (2001): **Runoff Treatment BMPs**; Stormwater Management Manual for Western Washington, Volume V. Washington State Department of Ecology, Publication 9915, URL <<http://www.ecy.wa.gov/biblio/9915.htm>>, June 2001.

National Conference on Urban Runoff Management: (1993): **Training for Construction Site Erosion Control and Stormwater Facility Inspection**; Enhancing Urban Watershed Management at the Local, County and State Levels.

Norman, D.K., Wampler, P.J., Throop, A.H., Schnitzer, E.F. and Roloff, J.M. (1997): **Best Management Practices for Reclaiming Surface Mines in Washington and Oregon**; Washington State Department of Natural Resources Open File Report 96-2 and Oregon Department of Geology and Mineral Industries Open File Report O-96-2, page 2-27, URL <<http://www.wa.gov/dnr/htdocs/ger/pdf/bmp.pdf>> [PDF, 7.6 Mb], June 2001.

MAP CODE  
**OUTLT**

# OUTLET PROTECTION

**USE** Erosion  
Sediment

## What

➔ A rock lined apron and flow area at the outlet of a pipe or culvert, paved flume, lined waterway or other flow system.

## Purpose

- ➔ Prevents scour and erosion at water conveyance outlets.
- ➔ Minimizes the potential for downstream erosion by reducing the velocity of concentrated stormwater flows.

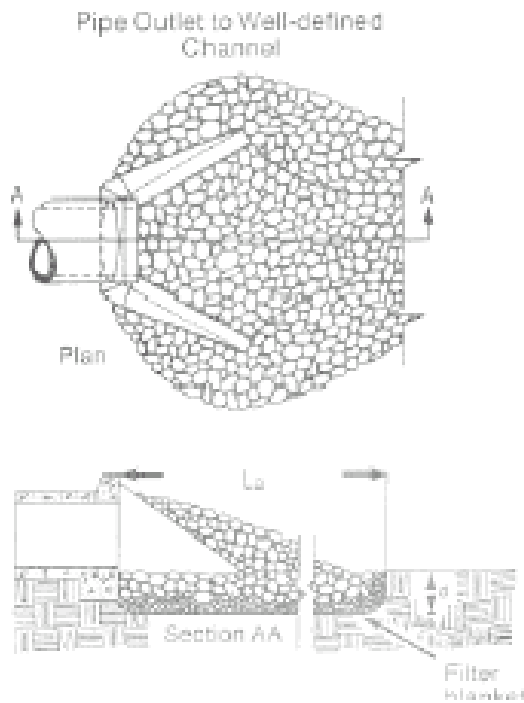

### Notes:

1.  $L_2$  is the length of the riprap apron.
2.  $d$  - 1.5 times the maximum stone diameter but not less than 6".
3. In a well-defined channel, extend the apron up the channel banks to an elevation of 6' above the maximum tailwater depth or to the top of the bank, whichever is less.
4. A filter blanket or filter fabric should be installed between the riprap and soil foundation.

Source: USDA-NRCS, 2001

## Where

**YES:** Outlet protection is required at the outlets of all ponds, stormwater systems, pipes, culverts, ditches and anywhere runoff is conveyed to a natural or manmade drainage feature such as a stream wetland, lake or ditch.

## Materials Equipment & Costs

- ➔ Riprap, filter fabric.
- ➔ Equipment to move materials.
- ➔ Low.

## Plans & Spec's

- Compact any fill required in the subgrade to the density of the surrounding undisturbed material. Low areas in the subgrade on undisturbed soil may also be filled by increasing the riprap thickness.
- The minimum thickness of the riprap should be 1.5 times the maximum stone diameter.
- Construct the apron with no overfall at the end. Make the top of the riprap at the downstream end level with the receiving area or slightly below it.
- Immediately after construction, stabilize all disturbed areas with hydroseeding or any other proven method.

## Installation

- Use the 10 year peak runoff or the design discharge of the water conveyance structure (whichever is greater) to size the outlet production.
- With low flows, vegetation, including sod, can be effective.
- If the water discharges directly into a well-defined channel, extend the apron across the channel bottom and up the channel banks to an elevation of 15 centimetres.

## Maintenance

- Inspect riprap outlet structures after heavy rains to see if any erosion has taken place around or below the riprap, or if stones have been dislodged.
- Add rock as needed to maintain the intended function.
- Immediately make all needed repairs to prevent further damage.

## Sources

Austin, L. (2001): **Construction Stormwater Pollution Prevention**; Stormwater Management Manual for Western Washington, Volume II. *Washington State Department of Ecology*, page 129, Publication 9912, URL <<http://www.ecy.wa.gov/biblio/9912.html>>, June 2001.

United States Department of Agriculture, (1994): **Planning and Design Manual for the Control of Erosion, Sediment, and Stormwater, Best Management Practice Standards.**

MAP CODE  
PPREV

# Pollution Prevention

**USE**  
Emergency Spills  
Stormwater  
Waste  
Site Environmental

## What

☛ Any structure, practice or method used to manage potential pollutants that are used or stored at an aggregate operation.

## Purpose

☛ To prevent or minimize contamination of stormwater and groundwater by protecting and containing chemicals and petroleum products.



## Where

**YES:** Wherever potential pollutants are handled or stored, such as at refuelling depots, maintenance sheds and shops.

**NO :** Covered containment is not necessary for benign materials storage (i.e., materials that are not considered pollutants).

## Materials, Equipment & Costs

☛ Concrete or other impervious floor, a suitable structure of lumber, plywood, roofing tiles or galvanized metal, metal shipping containers, tarpaper, concrete, polyvinyl, tanks, drums, barrels, lube cubes, absorbants (such as polypropylene, sawdust, paper, corn cob, zeolites, vermiculite or clay granules), goggles, nitrile gloves, disposal bags.

☛ Drum dolly, spill kits, labour and hand tools.

\$ Low to moderate.

## Plans & Specs

### Covered Containment

- Covered containment is any permanent or portable shed/structure which protects the potential pollutants from rain, and prevents spills from percolating into the ground.
- The size, type and duration of containment will depend on the amount of material in storage, and handling requirements (drums, etc.).
- For a permanent structure, a berm or footing should be constructed around the perimeter of the storage area. It can be a simple concrete foundation where the structure is walled, or an impermeable berm in the case of an open or carport type of containment area.

- Large steel shipping containers are often used as portable self contained lockable covered containment sheds. These containers can be relocated around the aggregate site as operations shift from one area to another.

### **Impervious Containment**

- Impervious containment is meant to prevent spilled fluids from seeping into the soil or flowing into surface water courses.
- These berms and impervious surfaces should be located in areas such as fueling stations, where minor spills happen frequently.
- Ensure that the berm is large enough to contain all of the storage containers and material transfer activities (such as fueling), plus ten percent.

### **Drum Handling**

- Any flammable or combustible liquid should only be stored in containers specifically designed for them.
- Drums should be moved by drum dolly, and not rolled.
- Containers of 23 litres or less should be stored in an equipment box whenever being moved by vehicle.

### **Spill Kit**

- A spill kit should contain all of the equipment and supplies necessary to clean up spills of fuels or other contaminants before they spread or cause further damage.
- Locate emergency spill containment and cleanup kits in high potential spill areas. The contents of the kit should be appropriate for the type and quantity of potential contaminants stored at the facility. Carry kits on mobile equipment, diesel power plants and trucks.
- Disposal of used kits and recovered spill material should be carried out according to manufacturer's instructions and Provincial regulations regarding contaminants.

## **Maintenance**

- Ensure the roof or tarp does not leak, that the floor is cleaned regularly and that any cracks are repaired promptly.
- Plastic containers designated to carry petroleum products should not be more than 5 years old.
- Waste oil and solvents are usually considered to be special waste, and should be stored in a secondary containment. For disposal options for these materials, contact a regional [Ministry of Water, Land and Air Protection](#) office.

## **Sources**

Aggregate Producers Association of Ontario. (1999): **Environmental Management Guide for Ontario Pits and Quarries**, Version 2.0.

British Columbia Ministry of Environment, Lands and Parks and British Columbia Ministry of Forests. (1995): **Summary of Environmental Standards & Guidelines for Fuel Handling, Transportation and Storage**; Pollution Prevention and Remediation, Second Edition.

Ciuba, S. (2001): **Source Control BMPs**; Stormwater Management Manual for Western Washington, Volume IV. *Washington State Department of Ecology*, Publication 9914, URL <<http://www.ecy.wa.gov/biblio/9914.html>>, June 2001.

Johnson, K. Editor (1999d): **Spill Plan**; in Sand & Gravel General Permit. *Washington State Department of Ecology*, Water Quality Program, URL <<http://www.ecy.wa.gov/programs/wq/sand/spillpln.html>>, June 2001.



MAP CODE  
**RBSN**

# RETENTION BASIN

**USE**

Environment  
Pollution  
Prevention  
Siltation  
Stormwater

**What** ➔ A pond to hold stormwater and filter out sediment.

**Purpose** ➔ To retain stormwater runoff and to remove the majority of the sediment within the stormwater, by settling.  
➔ Not a settling pond for wash plant water.



Source: Center for Sustainable Design, Mississippi State University, 1999

**Where** **YES:** In a low area or natural drainage way. Basins should be located where stormwater naturally flows or collects.  
**NO:** Should not be constructed on streams or where failure can endanger fish habitat, human safety or property.

**Materials, Equipment & Costs** ➔ Earth, riprap, pipe, collars, seed for stabilization of disturbed soil.  
✂ Backhoe, labour.  
\$ Variable depending upon size and design.

**Plans & Specs** • Sediment basins are at best only 70-80 percent effective in trapping sediment which flows into them. Therefore, they should be used with other erosion control practices such as temporary seeding, mulching, diversion dikes, etc., to reduce the amount of sediment before it gets to the basin.

## Plans & Spec's cont'd

- The basin should be located to intercept the largest possible amount of runoff from the site. The best locations are generally low areas and natural drainage ways.
- Drainage into the basin can be improved by diversion dikes and ditches.
- Retention basins can be made with a number of designs, including:
  1. Simple dugout
  2. Embankment pond
- Contact the local Mines Branch Regional office for specific [Health, Safety & Reclamation Code](#) requirements and the local office of the [Ministry of Sustainable Resource Management](#) for environmental regulations related to larger retention basins.
  - There are a number of formulae for calculating the optimum size for stormwater retention basins, but they are beyond the scope of this handbook. Operators can obtain technical advice on these calculations from the above agencies.
  - A common approach is to construct a number of ponds in series, with the first to take out the coarsest material, and subsequent ponds to capture progressively finer suspended solids. A series of ponds allows one or more ponds to operate while another is being cleaned.
- A suggested maximum drainage area for a single basin is 10 hectares, unless designed by a professional engineer.
- The design capacity of the basin should be at about 50 cubic metres per hectare of drainage area. . The capacity of the basin may be roughly estimated as 40% x Height x Surface area, with the height measured from the bottom of the basin to the crest of the spillway.
- The sediment cleanout level should be 1/3 of a metre below the crest of the spillway.
- The length of the flow path that the water travels should be three to five times the width of the pond. This path length can be accomplished with baffles.
- Drainage options for the basin include armoured spillways, stand pipes and infiltration.

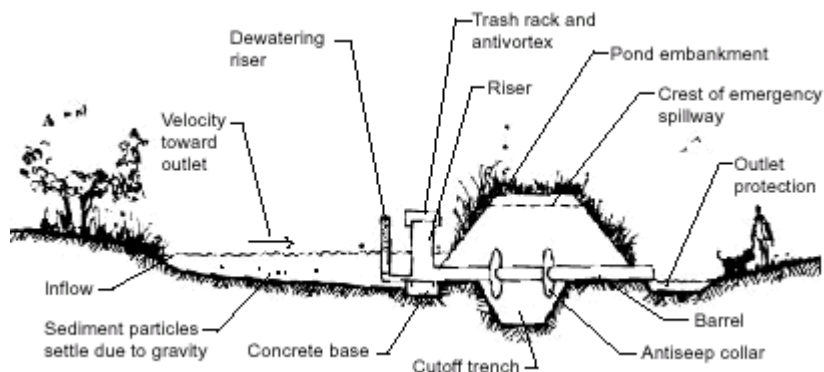

Source: Center for Sustainable Design, Mississippi State University, 1999

## Installation

- Only general retention basin design and construction practice instructions will be offered here.
- **Site Preparation**  
Clear, grub and remove the topsoil from the area. Compact the area if it has been built up with fill.
- **Embankment**  
Construct the embankment with clean mineral soil: free of roots, woody vegetation, oversized stones, rocks or other objectionable material. Areas on which mineral soil is to be placed should be previously scarified. The mineral soil should contain sufficient moisture to be formed into a ball by hand without crumbling. If water can be squeezed out of the ball, it is too wet for proper compaction. Place the mineral soil in 1.5-2.0 metres continuous layers over the entire length of the embankment. Compaction can be achieved by driving haul equipment over the mineral soil, so that the entire surface of the fill is traversed by at least one wheel or tread of the equipment. The embankment should be constructed to an elevation 10 percent higher than the design height to allow for settlement.
- **Stand Pipe**  
The riser of the standpipe can be perforated plastic pipes, T-intersections or screened.
- **Spillway**  
The spillway should not be routed over unprotected mineral soil. Design elevations, widths, entrance and exit channel slopes and armouring are critical to the successful operation of a spillway.
- **Vegetative Stabilization**  
The embankment and spillway of the retention basin should be stabilized with temporary vegetation within 15 days of completion of the basin.
- **Erosion and Sediment Control**  
The construction of the retention basin should be carried out in a manner that minimizes erosion and siltation of stormwater.

## Maintenance

- Clean out the retention basin before it becomes more than 1/3 full of sediment.

## Additional Considerations

- Due to the plastic nature of retention basin sludge, the area of the pond may have restricted land uses after aggregate operations have ceased. If any construction is planned for the area, complete removal of all sludge may be necessary. Alternative uses could be parks, designated gardens or local green spaces.

## Sources

- Austin, L. (2001): **Construction Stormwater Pollution Prevention**. Stormwater Management Manual ;for Western Washington, Volume II. *Washington State Department of Ecology*, Publication 9912, URL <<http://www.ecy.wa.gov/biblio/9912.html>>, June 2001.
- Chilibeck, B., Chislett, G. and Norris, G. (1992): **Land Development Guidelines for the Protection of Aquatic Habitat**; *Department of Fisheries and Oceans*, and *Ministry of Environment, Lands and Parks*, URL <<http://www-heb.pac.dfo-mpo.gc.ca/english/publications/PDF/guidelines/ldg.PDF>>, June 2001.
- United States Department of Agriculture and Mississippi State University. (1999): **Storm Water Retention Pond**; in Water Related BMP's in the Landscape/Best Management Practices/Water Runoff Control/D. Water Volume Management. *Watershed Science Institute United States Department of Agriculture and Mississippi State University*, <<http://abe.msstate.edu/csd/NRCS-BMPs/contents.html>>, October 2001.
- United States Department of Agriculture, (1994): **Planning and Design Manual for the Control of Erosion, Sediment, and Stormwater, Best Management Practice Standards**.
- United States Department of Agriculture. (2000): **Ponds--Planning, Design, and Construction**; Agriculture Handbook Number 590.
- Foroozan, L. (2001): **Hydrologic Analysis and Flow Control Design/BMPs**; Stormwater Management Manual for Western Washington, Volume III. *Washington State Department of Ecology*, page 93, Publication 9913, URL <<http://www.ecy.wa.gov/biblio/9913.html>>, November 2001.

MAP CODE  
MNTC

# SCHEDULED MAINTENANCE & REPAIRS

USE

Noise  
Risk Management  
Stormwater  
Pollution Prevention

## What

- ☛ A regular program of maintenance for vehicles and equipment on site.
- ☛ Hydraulic, transmission and engine oil and coolant leaks from vehicles and equipment are some of the most common spills at aggregate operations. A burst hydraulic hose on a large piece of mining equipment can pump tens of litres of hydraulic fluid into the environment in the few seconds before the operator can react and stop the equipment.

## Purpose

- ☛ Reduce the number of equipment breakdowns, amount of down time and frequency of spills or fuel leaks.
- ☛ Improve safety and protect water quality.

## Where

**YES:** Applies to all equipment, vehicles, storage areas, buildings and safety equipment.

## Materials, Equipment & Costs

- ☛ Lubricants, operating fluids, paints, building materials.
- ☛ Mechanic or labourer.
- \$ Low.



## Plans & Specs

- Schedule vehicle maintenance to reduce oil, fuel and coolant leaks.
- Vehicles and machinery require regular maintenance to ensure operator safety.
- Ensure that mufflers, shock absorbers and other noise reducing features are kept in excellent operating condition. This action will help reduce the potential for employee hearing loss, as well as minimize off-site noise impacts and protect surface and ground water quality.

## Maintenance

- Preventative maintenance can reduce the quantity and frequency of spills.
- Plan to fix equipment before it breaks by regularly replacing worn hoses and other consumable parts.
- Develop an individual maintenance program for each vehicle and piece of equipment according to amount of use and potential spill hazard.

## Sources

Johnson, K. Editor (1999d): **Spill Plan**; in Sand & Gravel General Permit. *Washington State Department of Ecology*, Water Quality Program, URL <<http://www.ecy.wa.gov/programs/wq/sand/spillpln.html>>, June 2001.

MAP CODE  
**SETL**

# SETTLING POND

**USE**

Environment  
Pollution  
Prevention  
Siltation  
Processing  
Stormwater

**What**      ➔ A settling pond is an integral part of any processing plant that washes aggregate. Settling ponds can be permanent or semi-permanent structures, dugouts, impoundments or raised tanks.

**Purpose**    ➔ Settling ponds remove silt and suspended clays from water used for washing aggregate, and/or from dirty stormwater.



Source: USDA Forest Service, 2001

**Where**      **YES:** Whenever water is used to wash aggregate, or when stormwater has picked up sediment or requires treatment prior to release to the environment.  
**NO:** Where the risk associated with a failure would pose significant risks for people or natural environments such as streams.

**Materials, Equipment & Costs**      ➔ Earth, riprap, pipe, collars, seed for stabilization of disturbed soil, new or recycled metal tanks.  
✂      Excavator, labourer.  
\$      Variable depending upon size and design.

## Plans & Specs

- Settling ponds can be made with a number of designs:
  3. Simple dugout
  4. Lined dugout
  5. Bermed pond
  6. Lined bermed pond
  7. Metal tank (new or recycled).
- Contact the local Mines Branch Regional office for specific [Health, Safety & Reclamation Code](#) requirements for larger bermed settling ponds. Larger settling ponds may also require confirmation by a professional engineer.
- A common approach is to construct two or more ponds in series, with the coarsest material removed by the first pond, and the finer suspended solids by subsequent ponds. This approach also allows one or more ponds to operate while another is being cleaned.
- There are a number of ways to calculate the optimum size for a settling pond, with the more technical being beyond the level of detail of this handbook. For sizing advice, an operator is advised to contact either the Regional Mines Branch office or the local office of the [Ministry of Sustainable Resource Management](#).
- Settling ponds should be designed for easy access for clean out with an excavator.
- Locate the settling pond close to the wash plant or, if it is used only for stormwater, close to where the collected stormwater will originate, such as the pit floor. The best locations are generally in low areas and natural drainageways, but NOT in streams or wetlands.
- The distance the water travels within the settling pond should be three to five times the width of the pond. This travel distance can be accomplished with baffles.
- Settling ponds only remove up to roughly 80 percent of the trapped sediment that flows into them. This removal rate should be adequate for recycling back into washing operations.
- For settling ponds used for stormwater only, check that the 80% removal is sufficient to meet allowable discharge turbidity limits. Water with high turbidity levels can be diverted to a land application through a level spreader or gravity fed application pipe (horizontal perforated PVC ).

## Installation

- As there are a wide variety of settling pond design types and construction practices, detailed instructions for pond installation are beyond the scope of this manual.
- Site Preparation - clear, grub and strip the topsoil from the area. Compact the area if it has been built up with fill.

## Maintenance

- Clean out the settling pond frequently and maintain a capacity of at least 110% of the volume of wash plant water.
- The pond should not be more than 2/3 full during normal operations.

## Additional Considerations

- Due to the plastic nature of settling pond sludge, the area of the pond may have restricted land uses after aggregate operations have ceased. If any construction is planned for the area, complete removal of all sludge may be necessary. Alternative uses could include parks, designated gardens or local green spaces.

## Sources

Foroozan, L. (2001): **Hydrologic Analysis and Flow Control Design/BMPs**; Stormwater Management Manual for Western Washington, Volume III. *Washington State Department of Ecology*, page 93, Publication 9913, URL <<http://www.ecy.wa.gov/biblio/9913.html>>, November 2001.

United States Department of Agriculture. (2000): **Ponds--Planning, Design, and Construction**; Agriculture Handbook Number 590.

British Columbia Ministry of Environment, Lands and Parks. (1997): **Guidelines for Assessing the Design, Size and Operation of Sediment Ponds Used in Mining**; *Pollution Prevention Branch*.





# SIGNAGE

USE

Public Relations  
Risk Management

**What**      ➤ Information and warning signs for the public and site visitors.

**Purpose**      ➤ To ensure that visitors to the site are aware that the site may be dangerous and that approval is required for entry.  
➤ To deter unauthorized persons from entry and reduce risk of injury.



Source: Ministry of Energy & Mines

**Where**      **YES:** In visually prominent locations at the entrance and exit to the operation, as well as at points around the perimeter of the site, particularly fence corners. Post signs at least every 15 to 30 metres and ensure that at least one sign is visible from any point along the fence line.

**Materials, Equipment & Costs**      🛠️ Plywood, metal sheeting, plastic signage products, stencils, paint, wire, nails or staples.  
⚙️ Fasteners for attaching signs to posts, fencing or buildings.  
\$ Low.

**Plans & Specs**

- All signs should be large enough to attract immediate attention, e.g., the “Active Mining Area” sign (shown above) should be at least 600 millimetres x 400 millimetres.
- Keep signs clean and in good repair to maintain maximum visual impact.
- Studies have determined that yellow attracts more attention than red; yellow background with black lettering is an effective combination.

**CAUTION  
OPEN EXCAVATION  
NO TRESPASSING**

- Where the pit property fence corners are obstructed by vegetation, the signs should be posted inside the cleared area or at the corners of the pit itself.
- Additional signs should be placed at intervals of no less than 15 metres and no more than 30 metres along the land or pit boundaries.
- Where stockpiles of material are expected to remain for an extended period, and are high enough to present a potential hazard, ramps should be barricaded to prevent vehicle access, and signs posted around the perimeter of the stockpile base to advise the public of potential safety hazards.

**CAUTION  
UNSTABLE MATERIAL  
KEEP OFF**

- Maintenance**
- Signs should be securely mounted and erected in such a way that they will not be easily damaged or stolen.
  - Periodically check all signs on the site to ensure they are clean, properly positioned and have not been damaged.

**Sources** Mah, K.L. (1987): **Security and Safety of Aggregate Pits**; *Alberta Transportation*, Aggregate Services, Materials Engineering Branch, Aggregates Bulletin #6.

MAP CODE  
**SILT**

# SILT FENCE

**USE** Erosion  
Environment  
Sediment  
Pollution

## What

- ☛ A temporary linear filter barrier of burlap or synthetic filter fabric and posts. Wire fencing is sometimes used as support.

## Purpose

- ☛ Used below disturbed areas to remove or reduce sediment in stormwater runoff and sheet or rill erosion.



Silt Fence  
Perspective View

## Where

- YES:** Perpendicular to the slope, below disturbed areas where runoff may occur in the form of sheet and rill erosion.
- NO:** Live streams or swales or ditch lines where flows are likely to exceed 1.0 cubic foot per second (0.3 metres per second).

## Materials, Equipment & Costs

- ☛ Burlap, synthetic filter fabric or geotextile; wire mesh for reinforcement (if necessary); wooden or steel fence posts and staples; wire and ground staples.
- ✂ Labour.
- \$ Low.

## Plans & Specs

- Use only where the size of the drainage area is no more than 0.10 hectares per 30 meters of silt fence length, the maximum slope length above the barrier is 30 meters, and the maximum gradient above the barrier is 50 percent.
- The height of a silt fence should not exceed 0.9 meters. Higher fences may impound volumes of water sufficient to cause failure of the structure.
- To avoid the use of joints, the filter fabric should be purchased in a continuous roll and cut to the length of the barrier.

- Excavate a trench approximately 100 millimeters wide and 100 millimeters deep along the line of stakes and upslope of the barrier. If posts are used rather than stakes, the trench should be 200 millimeters deep.
- When standard strength filter fabric is used, apply a wire fencing to support the fabric. Fasten the fence securely to the upslope side of the posts using heavy-duty wire staples, tie wires or hog rings. Attach the filter fabric to the fencing material with tie wires, plastic zip straps or hog rings.
- When extra strength filter fabric and closer post spacing are used, the wire mesh support fence may be eliminated. In such cases the filter fabric is stapled or wired directly to the posts.
- The trench is then backfilled and soil compacted over the filter fabric.

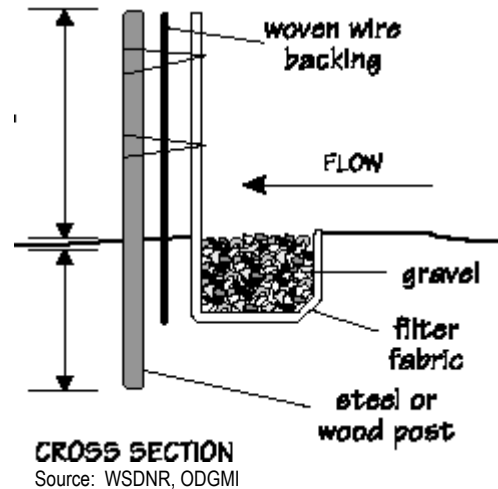

- If a silt fence is to be constructed across a ditch line or swale, the barrier should be of sufficient length to eliminate end flow, and the plan configuration should resemble an arc or horseshoe with the open ends oriented upslope.
- Regular inspections should be conducted after each rainfall and storm to ensure the fence is intact and debris and sediment has not accumulated at the bottom. Remove any deposits when they reach one-half the fence height.
- Silt fences and filter barriers may be removed when they have served their purpose, but not before the upslope area has been permanently stabilized.

## Maintenance

## Sources

Austin, L. (2001): **Construction Stormwater Pollution Prevention**; Stormwater Management Manual for Western Washington, Volume II. *Washington State Department of Ecology*, page 140 Publication 9912, URL <<http://www.ecy.wa.gov/biblio/9912.html>>, June 2001.

Norman, D.K., Wampler, P.J., Throop, A.H., Schnitzer, E.F. and Roloff, J.M. (1997): **Best Management Practices for Reclaiming Surface Mines in Washington and Oregon**; *Washington State Department of Natural Resources* Open File Report 96-2 and *Oregon Department of Geology and Mineral Industries* Open File Report O-96-2, page 2-15, URL <<http://www.wa.gov/dnr/htdocs/ger/pdf/bmp.pdf>>, June 2001.

United States Department of Agriculture and Mississippi State University. (1999): **Silt Fence**; in Water Related BMP's in the Landscape/Best Management Practices/Water Runoff Control/A). Construction Site Impact Reduction, *Watershed Science Institute United States Department of Agriculture and Mississippi State University*, <<http://abe.msstate.edu/csd/NRCS-BMPs/contents.html>>, October 2001.

United States Department of Agriculture, (1994): **Planning and Design Manual for the Control of Erosion, Sediment, and Stormwater, Best Management Practice Standards.**

MAP CODE  
**SINK**

# SINKING THE PLANT



**USE** Dust  
Noise

**What**      ➔ Locating noise generating stationary equipment, such as the processing plant, at a low location on the property; for example, the bottom of the worked pit.

**Purpose**      ➔ To contain noise and dust.

**Where**      **YES:** In urban and rural areas where noise may be a concern.

**Materials, Equipment & Costs**

	Berm building material.
	Excavator, front-end loader.
	Nil.

**Plans & Specs**

- Place noise-generating equipment, such as the crusher, in an excavated area below the surrounding terrain.
- Ensure that there is sufficient working space around the equipment so that other machinery can safely access the equipment for normal operations.
- Ensure that there is no danger of sloughing material entrapping personnel or equipment.
- Noise can "leak out" through openings; therefore ensure that there are no gaps in the noise barrier in the directions that noise reduction is most desired.
- Berms and acoustic fences, such as those constructed from used conveyor belts, can be used effectively in combination with a cliff, pit face or pit wall.

**Maintenance**

- Inspect the area for:
  1. Sufficient space for safety and working area
  2. Sloughing
  3. Noise reduction
- To create an effective barrier, the noise-dampening barrier will likely have to be adjusted on a regular basis.

**Sources**

Cole, L., Smith, P., Wright, J. and Clough, R. (1999): **Controlling the Environmental Effects of Recycled and Secondary Production Good Practice Guidance**; United Kingdom Department of the Environment, Transportation and the Regions, URL  
<<http://www.planning.detr.gov.uk/recycled/practice/index.htm>>, June 2001.

MAP CODE  
SDRN

# SLOPE DRAIN

**USE**  
Erosion  
Sediment  
Stormwater

## What

☛ A flexible tube or conduit extending from the top of a cut or fill slope to the bottom.

## Purpose

☛ To temporarily conduct concentrated stormwater runoff safely down the face of a cut or fill slope without causing erosion on or below the slope. Temporary slope drains provide valuable protection of exposed slopes until permanent draining structures and erosion control vegetation can be installed.



Source: USDA, 1999

## Where

**YES:** On cut or fill slopes before permanent stormwater drainage structures are installed and before permanent erosion control vegetation is established.

## Materials, Equipment & Costs

- ☛ Heavy-duty flexible conduit designed for this purpose, hold down grommets, stakes, riprap for outlet protection.
- ☛ Backhoe, labour.
- \$ Low.

## **Plans & Specs**

- The recommended maximum drainage area per drain is 2 hectares.
- The slope drain should consist of heavy-duty flexible conduit designed specifically for this purpose.
- The diameter of the slope drain should be equal over its entire length.
- Reinforced hold-down grommets should be spaced at 3 metre intervals.
- The entrance to the slope drain should consist of a flared end-section or a standard t-section fitting. Watertight fittings should be used.

## **Installation**

- The entrance section should slope toward the slope drain at a minimum rate of 2 centimeter per metre.
- The soil around and under the entrance section should be hand-tamped in 10 centimeter lifts to the top of the dike to prevent piping failure around the inlet.
- The slope drain should be securely staked to the slope at the grommets provided.
- The slope drain sections should be securely fastened together and have watertight fittings.

## **Maintenance**

- The slope drain structure should be inspected weekly and after every storm and repairs made if necessary.
- Avoid placing any material or traffic on the slope drain.

## **Sources**

United States Department of Agriculture, (1994): **Planning and Design Manual for the Control of Erosion, Sediment, and Stormwater, Best Management Practice Standards.**



MAP CODE  
**STCLN**

# STREET CLEANING

**USE**  
Dust  
Traffic  
Sediment  
Risk Management

**What**      🗑️ Sweeping or cleaning the site entrance, the public roadway fronting the site, and on-site paved roads on a regular or as needed basis.

**Purpose**      🗑️ To reduce dust and stormwater sediment loading and maintain a clean appearance at the site entrance and adjacent public roads.



Parking Lot and Street Cleaning Sweeper

**Where**      **YES:** Site entrance, public road fronting the site, loading areas, haul roads, parking areas and truck aprons.

**Materials, Equipment & Costs**

- 🚛 Flusher truck, power street sweeper using dry or wet broom action and/or vacuum pickup.
- ✂️ None.
- 💰 Low.

**Plans & Specs**

- New street sweeping machines pick up much finer materials than older models, and therefore collect more dust particles and sediment-bound pollutants.
- Sweepers with high-powered vacuum systems can be effective in collecting surface sediment and dirt, while reducing the amount of dust released.

**Options**

- In some areas of the Province, street-cleaning companies can be contracted to keep the site entrance clean on a regular basis.

**Maintenance**

- Schedule a regular street cleaning program, as well as monitoring “as needed” requirements.

MAP CODE  
**TARP**

# TARPS

**USE**

Dust  
Erosion  
Stormwater

**What**      ➔ A piece of woven fabric or plastic sheeting material (tarpaulin) used to temporarily cover soil, raw materials, equipment or activities to provide protection from wind and rain.

**Purpose**   ➔ To prevent or reduce erosion, sloughing, dust and muddied stormwater runoff.



**Where**      **YES:** Stockpiled raw material, specialty items, benches and exposed topsoil, overburden, idle equipment.

**Materials, Equipment & Costs**

- ➔ Tarpaulins made of synthetic fabric of vinyl, vinyl-coated polyester or polyethylene; canvas; pins or stakes; ropes or ties; weights (could be bricks, tires, sandbags, etc.).
- ✂ Labour to cover subject area or object and secure tarp.
- \$ Low.

**Plans and Specs**

- Black, green or brown tarps will reduce negative visual impact, as opposed to more vivid orange or blue colours commonly available.
- Tarps should be put in place as quickly as possible to minimize erosion and dust.
- Tarps need to be secured using stakes, tie downs, tires, etc., to avoid being blown away by the wind.
- When using several tarps to cover an area, place the lowest tarp first and lay subsequent tarps in an overlapping shingle fashion to ensure water is unable to seep through at the edges.
- Tarps are a short term, temporary solution. If long-term protection is required, consider using vegetation and silt fences to control stormwater erosion and dust.

- Maintenance**
- Deterioration will occur due to sunlight and wind. Regular inspections should be conducted to ensure that no holes or gaps are present.
  - Tarps should be repaired or replaced if they become damaged.

**Sources** King County Washington (1999): **Stormwater Pollution Control Manual**; Department of Natural Resource, Water and Land Division, URL <<http://dnr.metrokc.gov/wlr/dss/spcm.htm>>, October 2001.

MAP CODE  
**TARP**

# TILLAGE

**USE**

Erosion  
Reclamation  
Sediment  
Control  
Water Quality

## What

- Roughening of exposed soil surface with horizontal grooves running across the slope.
- Achieved by tractor with disc attachment or by stair stepping or tracking with construction equipment.
- Often done during reclamation.

## Purpose

- To shape the surface of the soil and create pockets that prevent runoff, minimize pondage, and catch and retain moisture.
- Can also break up restrictive layers below normal plough depth that inhibit water movement or root development.
- Aids the establishment of vegetative cover, improves water infiltration and decreases runoff velocity.

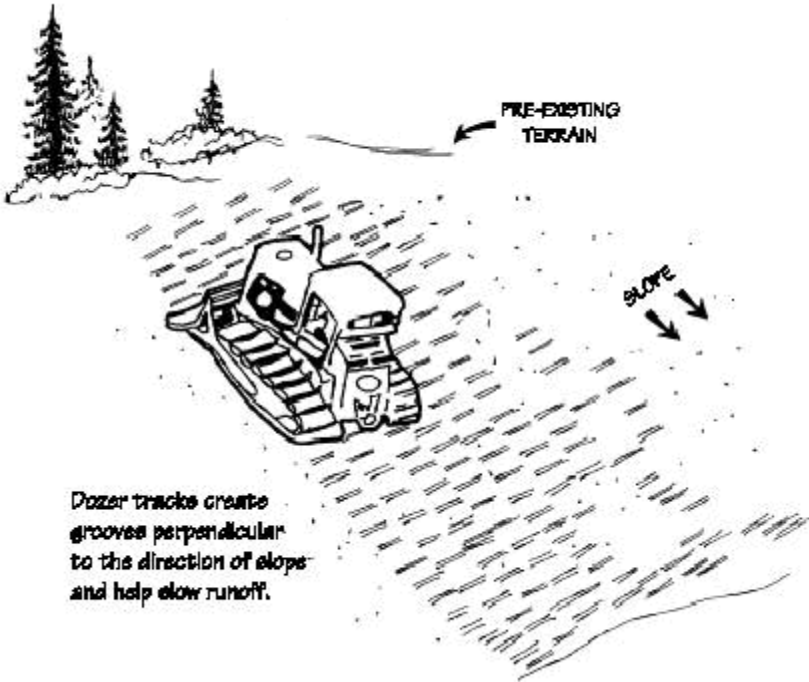

Source: Center for Sustainable Design, Mississippi State University, 1999

## Where

**YES:** During reclamation, especially in poorly drained or compacted areas. Also, any flat to nearly flat land having poor drainage, such as recently reclaimed areas or cleared or grubbed areas not yet put into extraction.

## Materials, Equipment & Costs



- None.
- Bulldozer, tractor, harrow or chisel blades.
- Minimal.

## Plans & Specs

- A neat or uniform appearance is not important: the rougher the soil, the better.
- Grooves can be large-scale, such as stair-step grading with small benches or terraces, or small-scale, such as grooving with disks, tillers or other machinery.
- Heavy tracked machinery should be used only if soil is sandy and non-compressible.
- Restrictive soil layers should be less than 40 centimetres deep.
- Bedding is a technique of creating narrow width ploughed tracks with equally spaced dead furrows running perpendicular to the prevailing land slope. This configuration is accomplished by moving soil toward the centre of beds to form a series of ridges and dead furrows (troughs) that will minimize runoff and pondage.

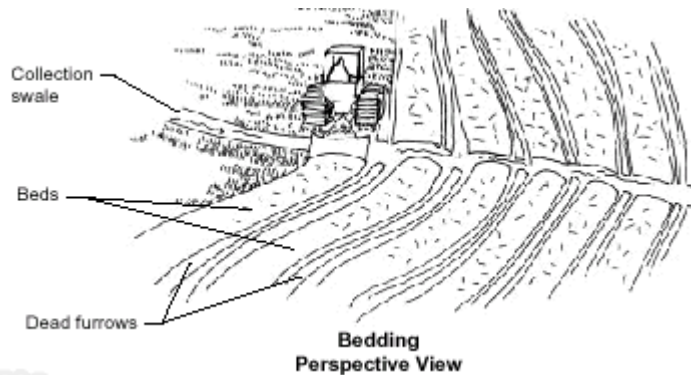

Source: NRCS, 1999

## Maintenance

- Minimal.
- Inspect roughened areas after heavy rainfalls to ensure erosion has not occurred.

## Sources

Smolen, M.D., D.W. Miller, L.C. Wyatt, J. Lichthardt, A.L. Lanier, W.W. Woodhouse and S.W. Broome (1988): **Erosion and Sediment Control Planning and Design Manual**; North Carolina Sedimentation Control Commission, NC Dept. of Natural Resources and Community Development.

United States Department of Agriculture (1999): **NRCS National Handbook of Conservation Practices**; Natural Resources Conservation Service.

United States Department of Agriculture and Mississippi State University. (1999): **Chiseling**; in Water Related BMP's in the Landscape/Best Management Practices/Water Runoff Control/B. Source Reduction. *Watershed Science Institute United States Department of Agriculture and Mississippi State University*, <<http://abe.msstate.edu/csd/NRCS-BMPs/contents.html>>, October 2001.

MAP CODE  
SOIL

# TOPSOIL MANAGEMENT

**USE**  
Dust  
Erosion  
Sediment  
Visual

## What

☛ Salvaging, storing and using topsoil for rehabilitation.

## Purpose

- ☛ To retain site topsoil for rehabilitation and/or permit requirements.
- ☛ To preserve topsoil quality during moving and storage.



Topsoiling  
Perspective View

Source: US Department of Agriculture

## Where

**YES:** All areas with well-developed topsoil (i.e., thickness greater than 7 centimeters).

## Materials, Equipment & Costs

- ☛ None required.
- ☛ Earth moving equipment.
- \$ Low.

## Plans & Specs

### Materials

- Determine depth of topsoil on 10-metre spacing.
- The depth of material should be at least 7 centimetres. Soil factors such as rock fragments, slope, depth to water table and layer thickness affect the ease of excavation and spreading of topsoil.
- Keep topsoil separate from overburden, and store layers separately to ensure that material is restored in the same order that it was removed.
- Generally, the upper part of the soil that is richest in organic matter is most valuable.
- Organic soils such as muck and peat do not make good topsoil. They can be identified by their extremely light weight when dry.

### Stripping

- Strip topsoil only from those areas that will be disturbed by excavation, filling, road building or compaction by equipment. A 1.0 to 1.5 metre stripping depth is common, but depth will depend on the soil profile at the site. Determine depth of stripping by taking soil cores at several locations within each area to be stripped. Topsoil depth generally varies along a gradient from hilltop to toe of slope. Put sediment basins, diversions and other controls into place to manage stormwater before stripping.

### Stockpiling

- Select stockpile location to avoid slopes, natural drainage ways and traffic routes. At large sites, re-spreading is easier and more economical when topsoil is stockpiled in small piles near the areas where they will be used.
- Sediment barriers - use sediment fences or other barriers where necessary to retain sediment.
- Temporary seeding - protect topsoil stockpiles by temporarily seeding as soon as possible, within 30 days after the formation of the stockpile.
- Permanent vegetation - if stockpiles will not be used within 12 months they should be stabilized with permanent vegetation to control erosion and weeds.

## **Installation**

### Site Preparation

- Before spreading topsoil, establish erosion and sedimentation control structures such as diversions, berms, dikes, waterways and sediment basins.
- Maintain grades on the areas to be topsoiled according to the approved plan. Adjust grades and elevations for receipt of topsoil.
- Roughening - Immediately prior to spreading the topsoil, loosen the subgrade by diking or scarifying to a depth of at least 100 millimetres to ensure bonding of the topsoil and subsoil.
- Ensure that soil horizons are replaced in the same order that they were removed.
- Uniformly distribute topsoil to pre-mining thickness. If sufficient topsoil is available, a minimum compacted depth of a half metre on 3:1 slopes and one metre on flatter slopes is suggested. To determine the volume of topsoil required to various depths, use the table below. Do not spread topsoil while it is frozen or muddy.

### **Volumes of topsoil required for various depths**

<b>Depth (millimetres)</b>	<b>Cubic metres per 100 square metres</b>	<b>Cubic metres per hectare</b>
25	2.5	250
50	5.0	500
75	7.5	750
100	10.0	1000
125	12.5	1250
150	15.0	1500

- Compact the topsoil enough to ensure good contact with the underlying soil, but avoid excessive compaction, as it increases runoff and inhibits seed germination. Light packing with a roller is recommended where turf is to be established.
- On slopes and areas that will not be mowed, the surface may be left rough after spreading topsoil.

## Options

### Live Topsoiling

- Live topsoiling is extracting topsoil from its place of origin and placing it directly onto an area that has already been mined, backfilled and graded for reclamation.
- This is the most desirable topsoil management option, as the topsoil is handled only once and does not compact during storage within stockpiles.

## Maintenance

- Minimize erosion with timely planting of temporary or permanent vegetation.
- Ensure that temporary or permanent plantings are well watered until established.
- Inspect stockpiles regularly, especially after large storms. Stabilize any areas that have eroded.

## Sources

Austin, L. (2001): **Construction Stormwater Pollution Prevention**; Stormwater Management Manual for Western Washington, Volume II. *Washington State Department of Ecology*, page 81, Publication 9912, URL <<http://www.ecy.wa.gov/biblio/9912.html>>, June 2001.

Norman, D.K., Wampler, P.J., Throop, A.H., Schnitzer, E.F. and Roloff, J.M. (1997): **Best Management Practices for Reclaiming Surface Mines in Washington and Oregon**; *Washington State Department of Natural Resources Open File Report 96-2 and Oregon Department of Geology and Mineral Industries Open File Report O-96-2*, page 3-13, URL <<http://www.wa.gov/dnr/htdocs/ger/pdf/bmp.pdf>>, June 2001.

United States Department of Agriculture and Mississippi State University. (1999): **Topsoiling**; in *Water Related BMP's in the Landscape/Best Management Practices/Water Runoff Control/ A. Construction Site Impact Reduction. Watershed Science Institute United States Department of Agriculture and Mississippi State University*, <<http://abe.msstate.edu/csd/NRCS-BMPs/contents.html>>, October 2001.

United States Department of Agriculture, (1994): **Planning and Design Manual for the Control of Erosion, Sediment, and Stormwater, Best Management Practice Standards**.



MAP CODE  
**VEGC**

# VEGETATION COVER

**USE**

Dust  
Erosion  
Noise  
Stormwater  
Visual

## What

- ☛ Ground cover (grasses & legumes), trees, shrubs or perennial plants.
- ☛ Sometimes consists of planting naturally occurring species to enhance existing cover.
- ☛ Vertical density of large shrubs and trees creates a vegetative "screen".

## Purpose

- ☛ To minimize or control dust and erosion, enhance water quality or facilitate reclamation.
- ☛ When densely planted, can control the growth of noxious weeds.



**Bank Planting  
Perspective View**

Source: Mississippi State University

## Where

**YES:** At any location where plant life will control dust creation (a dense vegetative cover), dust transportation (vegetative screen), erosion (fibrous root system), water quality (filtering, oxygenating aquatic plants), help to preserve topsoil and overburden or facilitate reclamation (re-establishment of native plant life).

## Materials, Equipment & Costs

- ☛ Plants seeds and fertilizer appropriate to the situation
- ☛ Backhoe, shovel, broadcast seeders, piping or hoses, labour and sprinklers.
- \$ Low.

## Plans & Specs

- Dependent on individual situation (see table below):

### Planning suggestions for vegetation cover

Situation	Planning Suggestions
Dust control	dense vegetative screen of trees and shrubs, ground cover
Erosion control	fast growing grass or groundcover with a fibrous root system
Water treatment	marginal plants, filtering and oxygenating aquatic plants

- Vegetative cover should also be considered for stockpiles of topsoil and overburden to seal and control dust and limit erosion.
- Native plantings are the best to use for reclamation as they generally require less maintenance. Avoid introducing a foreign species into an ecosystem.
- A bioengineering specialist may be consulted for use of vegetation to control erosion, and to tailor a seed mix specifically optimized for the site.
- Ongoing irrigation may be required for well-drained or south-facing sites.

## Maintenance

- Ensure newly planted material receives sufficient water and fertilizer until established.
- All newly planted vegetation should be checked regularly, and difficult sites may require special attention such as more or less water, wind protection, etc.

## Sources:

United States Department of Agriculture and Mississippi State University. (1999): **Native Revegetation - Grasses, Legumes, and Forbs** and **Native Revegetation - Trees and Shrubs**; in *Water Related BMP's in the Landscape/Best Management Practices/Water Runoff Control/ C. Erosion Control, and Temporary Seeding, in .../ A. Construction Site Impact Reduction, Watershed Science Institute United States Department of Agriculture and Mississippi State University*, <<http://abe.msstate.edu/csd/NRCS-BMPs/contents.html>>, October 2001.

MAP CODE  
**VIBR**

# VIBRATION REDUCTION

**USE** Dust  
Air Quality  
Noise

## What

- ☛ The reduction of minor ground movements generated by production blasts, crushers and haul trucks driving over rough ground.

## Purpose

- ☛ To reduce minor ground vibrations that may annoy neighbours and negatively affect the community's acceptance of the operation.



## Where

**YES:** Blasting, drilling, screening, crushing, grading processed material, transporting of processed material.

## Plans & Specs

- The main cause of vibration during transport is uneven road surfaces. The level of vibration depends upon the vehicle speed and weight, type of soil and the size of road surface irregularities.
- Consult with a drilling and blasting specialist regarding blast pattern and procedures.
- Remove significant road surface irregularities.
- Reduce speeds.
- Re-route dump trucks to less sensitive roads.
- introduce a weight limit on sensitive roads.
- Monitor vibrations at the nearest receptor during blasting. Considerations include the charge weight per delay, length of delay, blast hole spacing and firing sequence.

## Maintenance

- Monitor for potholes.

## Sources

Cole, L., Smith, P., Wright, J. and Clough, R. (1999): **Controlling the Environmental Effects of Recycled and Secondary Production Good Practice Guidance**; *United Kingdom Department of the Environment, Transportation and the Regions*, URL <http://www.planning.detr.gov.uk/recycled/practice/index.htm>, June 2001.

MAP CODE  
**WATER**

# WATER SPRAY

**USE** Dust

**What**

☛ The use of water sprays, sprinklers, mists or foams wherever dust is created at the aggregate site.

**Purpose**

☛ To control dust generation and dispersal with water. Foams and wetting agents can enhance the effectiveness of water in binding dust particles.

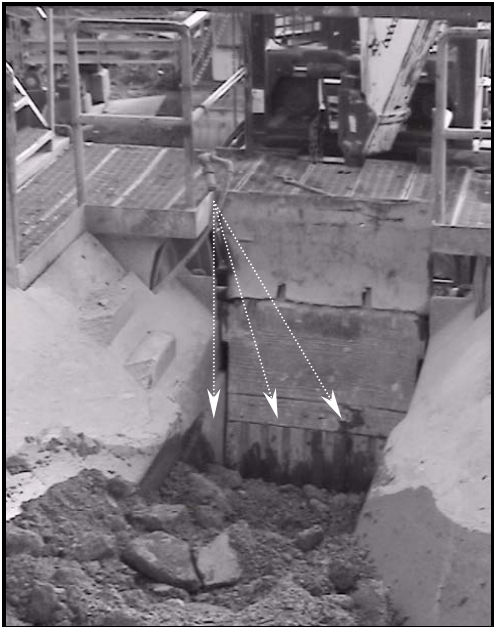

Photo: Sedun (RMX Recycling Ltd., Victoria)

**Where**

**YES:** Feeds and discharges for crushers, screens, transfer point for conveyors, stockpiles, and non-covered trucks ready for departure.

**Materials,  
Equipment  
& Costs**



Agricultural sprinklers or foggers, irrigation pipe, automated dust control water spray or bar system.



Hand tools necessary for installation.



Dependant upon system.

**Plans &  
Specs**

- Use elevated agricultural sprinklers for stockpile areas.
- Use sprinklers, sprayers and foggers for local dust control.
- Water systems require careful design with consideration of automation, supply requirements, spray head configuration, prevention of freezing and clogging due to dust.
- With water sprays and mists, a surface wetting is all that is required. Too much water will necessitate drying of material and cause machine wear and tear.

- Most water suppression should use fine mists rather than large quantities of water, with the exception of elevated sprinkler systems.
- Positioning the spray heads close to the dust source will allow for use of mist, as smaller water droplets cannot travel as far as larger ones.

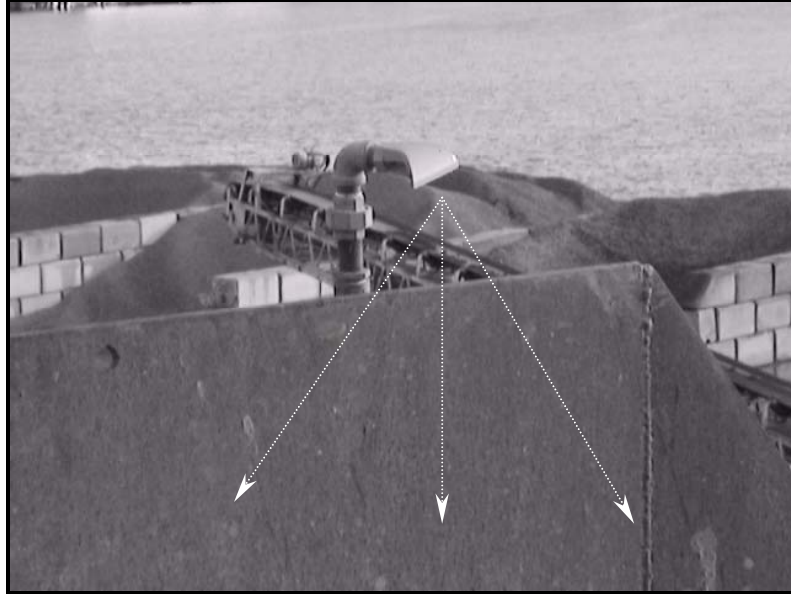

Photo: Sedun (RMX Recycling Ltd., Victoria)

- Maintenance**
- Regular inspections are required to ensure that mineral deposits do not build up inside the nozzles.
  - Take precautions to avoid damage to the system during freezing temperatures.

**Sources:** Aggregates Manager (2000): **Contemporary Solutions to Dust Control Problems**, Operation Strategies.

MAP CODE  
**WWASH**

# WHEEL WASHER

**USE**

Dust  
Public Relations  
Sediment

## What

➔ A washing pit or trough that removes rocks and dirt from vehicle wheels and wheel wells as they drive through.

## Purpose

- ➔ To reduce the amount of dirt and rock carried by aggregate vehicles onto public roads, thus lessening the need for street sweeping and preventing windshield damage.
- ➔ To create a cleaner, less dusty site by collecting the material in one place.

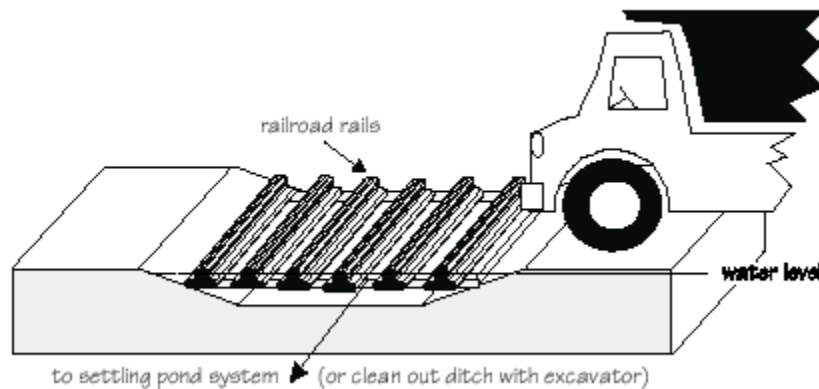

## Where

**YES:** Between the scale and the property exit.

## Materials, Equipment & Costs

- ➔ Railroad rails, steel bars or grid, gravel, water.
- ➔ Back hoe and labourer.
- \$ Medium to high.

## Plans & Specs

- Wheel washers can range from simple troughs to concrete foundations with embedded rails.
- The basic wheel washer is a shallow pit filled with water.
- A rumble strip on the bottom of the pit, such as a cattle guard, railroad rails or steel bars spaced 5 to 20 centimeters apart, can agitate/shake mud and dirt off the vehicle.
- High volume wheel washers may need a concrete foundation.
- Mechanized spray washers are also available through commercial suppliers.

- Allow at least 20 metres between the wheel washer and the exit for wetted material to spin off tires as the vehicle comes up to speed, and for other material to drop off the chasis.
- A paved exit will also help reduce the amount of dirt and rocks deposited on public roads by vehicles leaving the site.
- Dry options use only mechanical agitation to remove dirt and mud.
- On more remote sites, 30 metres of loose clean gravel will remove a good portion of mud from the tires.
- Cattle guards by themselves will also remove a significant amount of mud and dirt.

## Maintenance

- Dirty water can be directed to a settling pond, or the wheel wash can be cleaned out frequently with an excavator. Make sure that the water used in the wheel washer is treated to remove solids and turbidity before being discharged off the site.

## Sources

Norman, D.K., Wampler, P.J., Throop, A.H., Schnitzer, E.F. and Roloff, J.M. (1997): **Best Management Practices for Reclaiming Surface Mines in Washington and Oregon**; *Washington State Department of Natural Resources* Open File Report 96-2 and *Oregon Department of Geology and Mineral Industries* Open File Report O-96-2, 128 pages, URL <<http://www.wa.gov/dnr/htdocs/ger/pdf/bmp.pdf>>, June 2001.

MAP CODE  
**WIND**

# WIND PROTECTION

**USE**  
Dust  
Erosion  
Sediment

## What

☛ Any structure or method to block or reduce wind flow.

## Purpose

☛ To reduce the exposure of dust-generating material to wind, or reduce the velocity of wind, thus controlling dust generation and distribution and maintaining air quality.



## Where

**YES:** Primarily around processing equipment such as screens, crushers, conveyors, hoppers and chutes, but also around stockpiles and roads.

## Materials, Equipment & Costs

☛ Trees, plywood, lumber, tarps, metal sheeting, used tires (to make a wall or barrier).  
✂ Labour.  
\$ Low.

## Plans & Specs

- For the property as a whole, wind protection includes constructing treed berms and retaining as many original trees and shrubs as possible.
- For individual equipment or activity, wind protection includes placing barriers directly in front of dust generating activities to create small, localized wind shadows.
- The creation of small wind shadows will allow locally generated dust to fall out before it can be caught by the wind and carried off-site.
- Awareness of the wind direction and strength at the site will help in the placing of both large and localized wind barriers.

## Options

- Backstops  
Backstops are freestanding walls of plywood, fencing, used tires or used conveyor belts placed between the prevailing wind and any dust generating point sources.



- Diverter  
Diverter are smaller barriers attached to equipment or located right next to equipment or point sources of dust. They can be made from plywood or sheet metal.
- Vegetative Cover  
A dense vegetative screen consisting of trees and shrubs can reduce the impact of wind and resultant spread of dust on a specific location. Trees and shrubs require time to grow and are not mobile (see Vegetation Cover BMP).
- Containment / Enclosure  
Any type of enclosure for conveyors, chutes, process plant, stockpiles, etc. Enclosures can include hoods, dust socks, blasting mats and buildings in which plants such as crushers or screens can operate.
- Temporary Enclosures  
Can be constructed using sheet material such as plywood on scaffolding or masonry materials. Straw bail walls supported with scaffolding have also been effectively used for both wind and noise barriers.
- Bays or Bunkers  
Storing aggregate in bays or bunkers made with lumber or pre-cast concrete blocks will help shield granular material from the wind.
- Tarping loads  
Spillage and blow-off of fine material from dump trucks can be prevented by tarping the load (see [Tarps](#)).

**Maintenance** • Minimal, dependent on systems used.

## Sources

Thomas, M., Editor (2000): **Controlling and Mitigating the Environmental Effects of Minerals Extraction in England Consultation Paper**; Mineral Planning Guidance Note 11. *United Kingdom Department of the Environment, Transportation and the Regions*, URL <<http://www.planning.detr.gov.uk/consult/mpg11/index.htm>>, June 2001.

Brandle, J and Stange, C (2001): **Windbreak Management**; University of Nebraska, United States Department of Agriculture Natural Resources Conservation Service and Forest Service, North Dakota State University and the Forest Service Program of the Nebraska Forest Service.

Brandle, J., Kuhns, M., Stange, C., and Wilson, J. (2001): **Windbreak Renovation**; University of Nebraska, United States Department of Agriculture Natural Resources Conservation Service and Forest Service, North Dakota State University and the Forest Service Program of the Nebraska Forest Service.