

PROVINCE OF BRITISH COLUMBIA

Ministry of Forests

COPY

IN THE MATTER OF TREE FARM LICENCE NUMBER 47

INSTRUMENT NUMBER 8

Amendment

THIS AGREEMENT is dated the 16th day of July, 1992.

BETWEEN:

THE MINISTER OF FORESTS, on behalf of HER MAJESTY THE QUEEN
IN RIGHT OF THE PROVINCE OF BRITISH COLUMBIA, Parliament
Buildings, Victoria, British Columbia, V8V 1X4

(the "Licensor")

AND:

Crown Forest Industries Limited c/o
Fletcher Challenge Canada Limited
6th Floor, 815 West Hastings Street
P.O. Box 9502
Vancouver, British Columbia
V6B 5K9

(the "Licensee")

Whereas the lands described hereinafter are within
Tree Farm Licence Number 47, and are required for a B.C. Hydro and
Power Authority statutory right of way for the Dunsmuir - Gold River
transmission line.

And whereas the licensee has given his consent to the
withdrawal of the aforementioned lands from Schedule "A" of the said
tree farm licence;

Therefore, pursuant to Section 33.1 of the Forest Act, and
Paragraph 1.04 of the tree farm licence document, the licensor
hereby withdraws the following lands from Schedule "A" of the said
Tree Farm Licence Number 47:

1. That portion of Parcel C (DD71309N), Block 29,
Comox District, Plan 691F, 0.803 hectares.
2. That portion of the North 1/2 of the Northwest 1/4 of
Section 7, Township 6, Comox District, Plan 552E,
1.130 hectares.

3. That portion of the Southeast 1/4 of Section 7, Township 6, Comox District, Plan 552E, except those parts in Plan 204, R/W, 0.510 hectares.
4. That portion of the South 1/2 of the Northwest 1/4 of Section 7, Township 6, Comox District, Plan 552E, 1.360 hectares.
5. That portion of the South 1/2 of the Southwest 1/4 of Section 18, Township 6, Comox District, Plan 552E, 0.002 hectares.
6. That portion of the East 1/2 of the Southwest 1/4 of Section 7, Township 6, Comox District, Plan 552E, except that part in Plan 204, R/W, 0.128 hectares.

Namely, all that tract of land being more particularly shown outlined in bold black on the plan attached hereto and the said lands so withdrawn are and shall be henceforth no longer part of or subject to the said Tree Farm Licence Number 47.

This agreement has been executed by the licensor and licensee on the day and year first written above.

SIGNED, SEALED AND DELIVERED)
 by the Minister of Forests)
 on behalf of Her Majesty)
 the Queen in Right of the)
 Province of British Columbia)
 in the presence of:)
 _____)
 _____)
 _____)

F. B. Hallock
 for Minister of Forests

THE COMMON SEAL of the)
 Licensee was affixed in the)
 presence of:)

J. A. Bell)
 Authorized Signatory)
 _____)
M. M. [unclear])
 Authorized Signatory)

C/S

(or)

SIGNED, SEALED AND DELIVERED)
 by the Licensee in the)
 presence of:)
 _____)
 _____)
 _____)

 Authorized Signatory

 Title

COPY

NOTICE
OF
CANCELLATION
OF
CHARGE

PROVINCE OF BRITISH COLUMBIA

Ministry of Forests

TO THE REGISTRAR OF THE VICTORIA REGISTRATION DISTRICT

Pursuant to Section 260 of the Land Title Act, take notice that the following land herein is no longer subject to the provisions of the Forest Act:

Description of Lands

That portion of Parcel C (DD71309N), Block 29, Comox District, Plan 691F, more particularly shown outlined in bold black on the plan attached hereto.

Dated at the City of Victoria, British Columbia this 20th day of September, 1992.

FR Albritton
Minister of Forests

PLAN OF STATUTORY RIGHT OF WAY
 THROUGH PART SECS 7 AND 18
 Tp 6. COMOX DISTRICT PLAN 552E
 PLAN 552E
 PLAN 552E
 PLAN 552E

PLAN 552E
 PLAN 552E
 PLAN 552E
 PLAN 552E

NO.	DESCRIPTION	AREA
1
2
3
4
5
6
7
8
9
10

THE PLAN OF THE STATUTORY RIGHT OF WAY
 THROUGH PART SECS 7 AND 18
 Tp 6. COMOX DISTRICT PLAN 552E
 PLAN 552E

Detail Scale 1:500

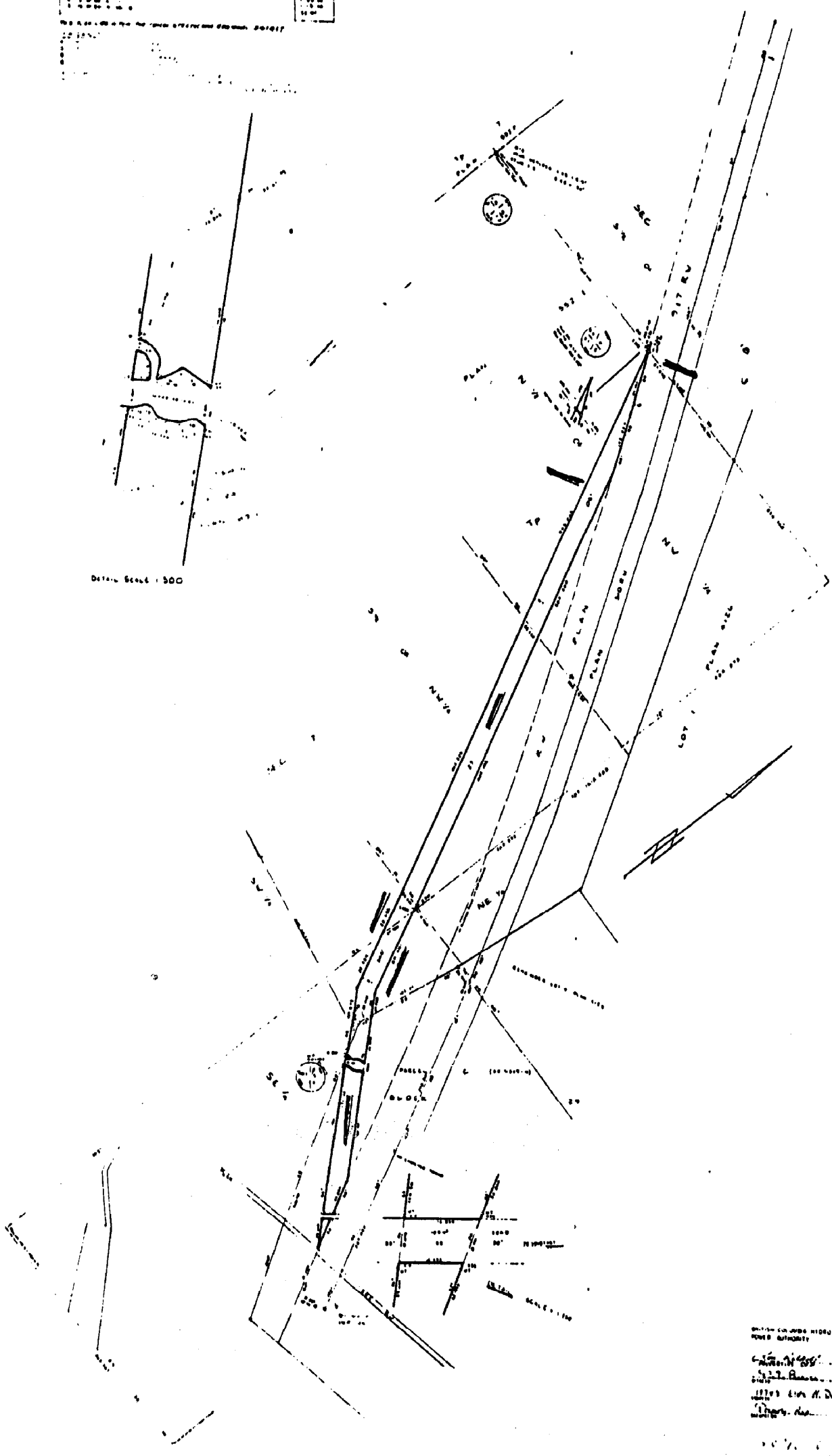

Surveyed and shown and
 their authority
 C. M. ...
 J. J. ...
 1973 ...
 ...

This plan is a copy of the original plan
 and is not to be used for any other purpose
 without the written consent of the
 Surveyor General of the Province of
 British Columbia.

COPY

NOTICE
OF
CANCELLATION
OF
CHARGE

PROVINCE OF BRITISH COLUMBIA

Ministry of Forests

TO THE REGISTRAR OF THE VICTORIA REGISTRATION DISTRICT

Pursuant to Section 260 of the Land Title Act, take notice that the following land herein is no longer subject to the provisions of the Forest Act:

Description of Lands

That portion of the North 1/2 of the Northwest 1/4 of Section 7, Township 6, Comox District, Plan 552E, more particularly shown outlined in bold black on the plan attached hereto.

Dated at the City of Victoria, British Columbia this 20th day of September, 1992.



F. B. Hall
Minister of Forests

PLAN V193292

BRITISH COLUMBIA HYDRO AND POWER AUTHORITY
PLAN OF STATUTORY RIGHT OF WAY
THROUGH PART OF SECS 7 AND 18
Tp 6, COMO STRICT PLAN 552E
S.C. 40 327 075

Scale 1:500
Project of 1988
Date of Issue: 1988

Prepared by: [Signature]
Checked by: [Signature]
Approved by: [Signature]

Symbol	Description	Scale
---	Proposed Right of Way	1:500
---	Proposed Right of Way	1:500
---	Proposed Right of Way	1:500
---	Proposed Right of Way	1:500
---	Proposed Right of Way	1:500
---	Proposed Right of Way	1:500
---	Proposed Right of Way	1:500
---	Proposed Right of Way	1:500
---	Proposed Right of Way	1:500
---	Proposed Right of Way	1:500

The Plan is subject to the provisions of the Statutory Right of Way Act.

LEGEND

- Proposed Right of Way
- Proposed Right of Way
- Proposed Right of Way
- Proposed Right of Way
- Proposed Right of Way
- Proposed Right of Way
- Proposed Right of Way
- Proposed Right of Way
- Proposed Right of Way
- Proposed Right of Way

DETAIL SCALE 1:500

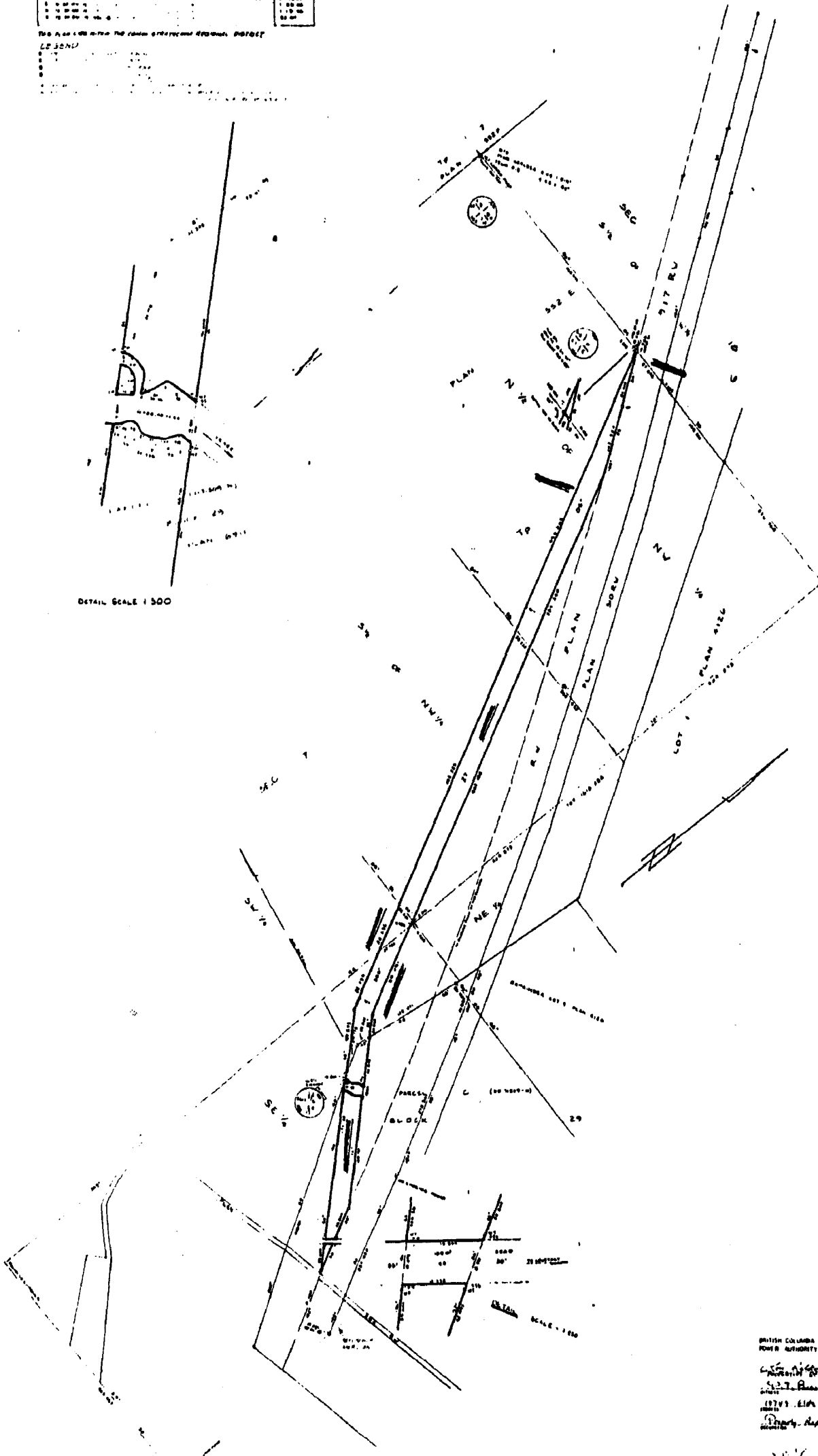

BRITISH COLUMBIA HYDRO AND POWER AUTHORITY
[Signature]
[Signature]
[Signature]

1988

1:500

COPY

NOTICE
OF
CANCELLATION
OF
CHARGE

PROVINCE OF BRITISH COLUMBIA
Ministry of Forests

TO THE REGISTRAR OF THE VICTORIA REGISTRATION DISTRICT

Pursuant to Section 260 of the Land Title Act, take notice that the following land herein is no longer subject to the provisions of the Forest Act:

Description of Lands

That portion of the Southeast 1/4 of Section 7, Township 6, Comox District, Plan 552E, except those parts in Plan 204, R/W, more particularly shown outlined in bold black on the plan attached hereto.

Dated at the City of Victoria, British Columbia this 20th day
of September, 1992.

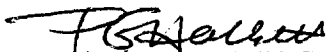

for Minister of Forests

BRITISH COLUMBIA HYDRO AND POWER AUTHORITY
 PLAN OF STATUTORY RIGHT OF WAY
 THROUGH PART OF SECS 7 AND 18
 Tp 6, COMO DISTRICT, PLAN 552E
 SCALE 1:500

APPROVED BY THE BOARD OF DIRECTORS OF
 BRITISH COLUMBIA HYDRO AND POWER AUTHORITY
 ON 15/01/2010
 DEPUTY CHIEF ENGINEER

NOTES: 1. THIS PLAN IS A STATUTORY RIGHT OF WAY PLAN AND IS NOT A CONVEYANCE OF LAND.
 2. THE PLAN IS SUBJECT TO THE RIGHTS AND INTERESTS OF THIRD PARTIES.
 3. THE PLAN IS SUBJECT TO THE RIGHTS AND INTERESTS OF THE CROWN AND OTHER GOVERNMENT DEPARTMENTS.
 4. THE PLAN IS SUBJECT TO THE RIGHTS AND INTERESTS OF THE PROVINCE OF BRITISH COLUMBIA.

DATE	DESCRIPTION	BY
15/01/2010	APPROVED	[Signature]
15/01/2010	APPROVED	[Signature]
15/01/2010	APPROVED	[Signature]
15/01/2010	APPROVED	[Signature]
15/01/2010	APPROVED	[Signature]
15/01/2010	APPROVED	[Signature]
15/01/2010	APPROVED	[Signature]
15/01/2010	APPROVED	[Signature]
15/01/2010	APPROVED	[Signature]
15/01/2010	APPROVED	[Signature]

THE PLAN IS SUBJECT TO THE RIGHTS AND INTERESTS OF THIRD PARTIES.
 THE PLAN IS SUBJECT TO THE RIGHTS AND INTERESTS OF THE CROWN AND OTHER GOVERNMENT DEPARTMENTS.
 THE PLAN IS SUBJECT TO THE RIGHTS AND INTERESTS OF THE PROVINCE OF BRITISH COLUMBIA.

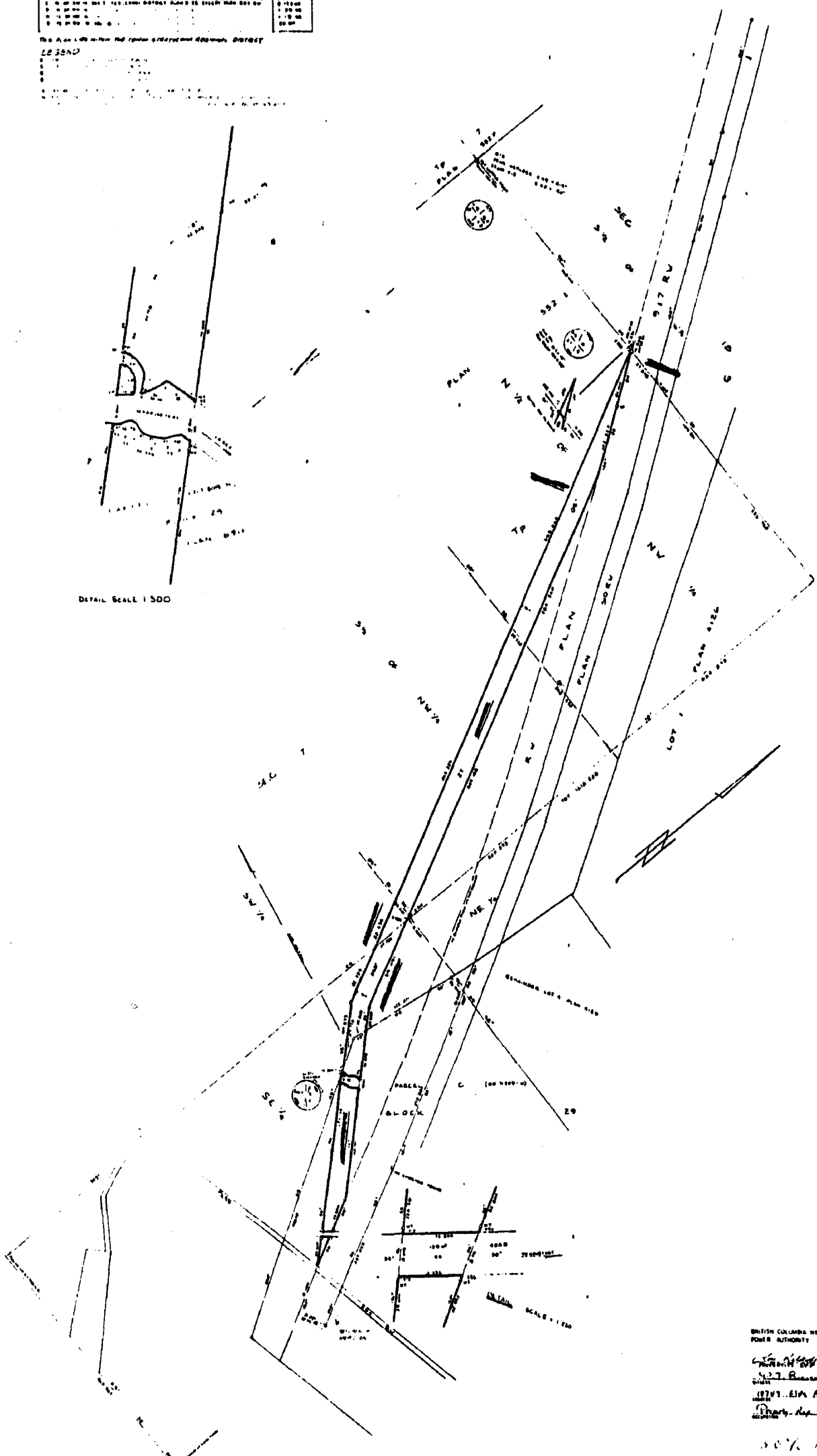

DETAIL SCALE 1:500

BRITISH COLUMBIA HYDRO AND
 POWER AUTHORITY
 [Signature]
 15/01/2010
 DEPUTY CHIEF ENGINEER

1:500 SCALE

COPY

NOTICE
OF
CANCELLATION
OF
CHARGE
PROVINCE OF BRITISH COLUMBIA
Ministry of Forests

TO THE REGISTRAR OF THE VICTORIA REGISTRATION DISTRICT

Pursuant to Section 260 of the Land Title Act, take notice that the following land herein is no longer subject to the provisions of the Forest Act:

Description of Lands

That portion of the South 1/2 of the Southwest 1/4 of Section 18, Township 6, Comox District, Plan 552E, more particularly shown outlined in bold black on the plan attached hereto.

Dated at the City of Victoria, British Columbia this 20th day of September, 1992.

F. S. Hall
for Minister of Forests

COPY

NOTICE
OF
CANCELLATION
OF
CHARGE
PROVINCE OF BRITISH COLUMBIA
Ministry of Forests

TO THE REGISTRAR OF THE VICTORIA REGISTRATION DISTRICT

Pursuant to Section 260 of the Land Title Act, take notice that the following land herein is no longer subject to the provisions of the Forest Act:

Description of Lands

That portion of the East 1/2 of the Southwest 1/4 of Section 7, Township 6, Comox District, Plan 552E, except that part in Plan 204, R/W more particularly shown outlined in bold black on the plan attached hereto.

Dated at the City of Victoria, British Columbia this 20th day of September, 1992.



Minister of Forests

