

TIMBER PRICING BRANCH

CGNF Standards and Procedures for the Coast Forest Area

Effective: July 1, 2021

Includes Amendments

Amendment No. 1

Effective Date

February 1, 2025



This manual is intended for the use of individuals or companies when conducting business with the British Columbia Government.
Permission is granted to reproduce it for such purposes.
This manual and related documentation and publications, are protected under the *Federal Copyright Act*. They may not be reproduced for sale or for other purposes without the express written permission of the Province of British Columbia.

Highlights

Section	Description
Throughout manual	Added new sorts 'High Grade Sawlog' and 'Mid Grade Sawlog' and removed sort 'Sawlog'.
1.4	Added clarity on assessing the 8m U grade log filter. Fixed typo.
Table 11	Added wording for butt rot grade consideration guidelines not to include shingle and pulp sorts.
2.3.14	Added clarity on assessing 8m U grade log filter.
3.2.1	Added verbiage regarding hierarchy of log sorts for log grading.
3.2.3.7	Updated verbiage regarding shingle grading process and Table 20.
3.2.3.10	Updated general grading guidance for grading the last log of mature tree tops.

Table of Contents

1. Introduction and Overview of Call Grading/Net Factoring.....	1-1
1.1. Definitions	1-3
1.2. Definitions	1-7
1.3. Call Grading and Net Factoring.....	1-8
1.3.1. Call Grading	1-8
1.3.2. Net Factoring.....	1-8
1.3.3. Tree Form	1-10
1.4. Conventions/Procedures for Call Grade Net Factoring.....	1-12
2. Net Factoring	2-1
2.1. Net Factoring Process	2-2
2.2. Net Factoring Deductions	2-3
2.2.1. Applying Deduction Rules	2-3
2.3. Deduction Procedures for Loss Indicators.....	2-5
2.3.1. Heart Rot Conk.....	2-5
2.3.2. Root Rot	2-6
2.3.3. Blind Conk	2-8
2.3.4. Frost Crack	2-8
2.3.5. Scar	2-10
2.3.6. Butt Rot/Cat Face	2-12
2.3.7. Fork	2-17
2.3.8. Crook	2-18
2.3.9. Rotten Branch.....	2-19
2.3.10. Dead Tops.....	2-19
2.3.11. Broken (Missing) Tops.....	2-20
2.3.12. Fallen Trees	2-22
2.3.13. Multiple Defects	2-22
2.3.14. Dead Standing and Dead Fallen Trees	2-24
3. Call Grading	3-1

3.1.	Introduction	3-2
3.2.	Definitions	3-3
3.2.1.	Procedures	3-3
3.2.2.	Grading Conventions and Guidelines.....	3-4
3.2.3.	Guidelines.....	3-5
3.2.3.1.	Heart Rot:	3-5
3.2.3.2.	Butt Rot	3-5
3.2.3.3.	Frost Cracks	3-6
3.2.3.4.	Occasional Larger Knots.....	3-6
3.2.3.5.	Weather Checks and/or Insect Damage	3-6
3.2.3.6.	Twist.....	3-8
3.2.3.7.	Cedar Shingle Criteria.....	3-10
3.2.3.8.	Lumber Grades.....	3-10
3.2.3.9.	Tree Form.....	3-11
3.2.3.10.	Last Log.....	3-11
3.2.3.11.	Dead/Dry Tops	3-11
3.2.3.12.	Ring Shake	3-11
3.3.	Missing Wood and Separated Pieces.....	3-12
3.4.	Revenue Call Grading Criteria	3-13
4.	Quality Assurance	4-1
4.1.	Primary Standards.....	4-3
4.2.	Appraisal Standards.....	4-4
4.3.	Plot Selection.....	4-5
4.4.	Preparing the Quality Assurance Summary.....	4-6
4.5.	Acknowledgements	4-7
5.	Appendices	5-1
5.1.	Appendix 1: Damage Codes	5-2
5.1.1.	Insect	5-2
5.1.2.	Fire	5-2
5.1.3.	Down Tree.....	5-2
5.2.	Appendix 2: Coast Tally Card Details.....	5-3
5.3.	Appendix 3: Transition from Loss Factor to CGNF Cruising.....	5-7

List of Figures

Figure 2-1 Example of Net Factor Calculation for Root Rot on the Ground 2-6
Figure 2-2 Example of Net Factor Calculation for Root Rot on the Tree 2-7
Figure 2-3 Example of Net Factor Calculation for Frost Cracks 2-9
Figure 2-4 Examples of a Net Factor Calculation for Scars with Known Depth 2-12
Figure 2-5 Example of Net Factor Calculation for Cylindrical Defect 2-13
Figure 2-6 Example of Net Factor Calculation (conical) 2-14
Figure 2-7 Example of Net Factor Calculation (cylindrical & conical) for Cedar
Shingle 2-15
Figure 2-8 Example of Net Factor Calculation (using butt rot table)..... 2-17
Figure 2-9 Example of Sounding Deduction 2-17
Figure 2-10 Example of Net Factor Calculation for Measurable Sap Rot 2-20
Figure 2-11 Example of Net Factor Calculation for Broken Tops with Decay 2-21
Figure 2-12 Example of Isolated Sections between Defects 2-23
Figure 3-1 Example of Grade Calculation for Weather Checked Logs 3-8
Figure 3-2 Examples of Grade Calculation for Twist 3-10
Figure 5-1 FS 205 – Cruise Tally Sheet 5-3

List of Tables

Table 1 Summary of Sorts, Grades, Standard Log Lengths and Application Notes 1-9
Table 2 Helicopter log lengths to be used based on estimated top DIB 1-11
Table 3 Formula for Calculating Volume..... 2-3
Table 4 Summary of Procedures for Determining Net Factor for Loss Indicators 2-3
Table 5 Deduction Procedure for Heart Rot Conk 2-5
Table 6 Deduction Procedure for Root Rot 2-6
Table 7 Deduction Procedure for Blind Conk 2-8
Table 8 Deduction Procedure for Frost Crack 2-8
Table 9 Deduction Procedure for Scar 2-10
Table 10 Deduction Procedure for Butt Rots 2-12
Table 11 Butt Rot Guide for Length Deductions 2-16
Table 12 Deduction Procedure for Fork with Visible Decay 2-18
Table 13 Deduction Procedure for Crook with Visible Decay 2-18
Table 14 Deduction Procedure for Rotten Branch with Visible Decay 2-19
Table 15 Deduction Procedure for Measurable Sap Rot 2-20
Table 17 Deduction Procedure for Rot Associated with Log Below Broken Top 2-21
Table 18 Butt Rot Guide for Length Deductions 3-6
Table 19 Maximum Twist Displacement by Grade..... 3-9

Table 20 Falldown of Lumber and Sawlog Grades to Shingles due to Defect3-10

1. Introduction and Overview of Call Grading/Net Factoring

The standards in this manual are developed to assess the use of net factoring and call grading (CGNF) procedures for the coastal appraisal system. This manual contains the standards and procedures used to call grade and net factor timber for appraisal cruising in coastal B.C. They replace the use of the 1976 loss factors and computer grades. See the current *Cruising Manual* for other procedures and standards.

They are a combination of standards and procedures commonly used by the forest industry and the Ministry of Forests, Lands and Natural Resource Operations (FLNR), Forest Analysis and Inventory Branch.

CGNF uses cruiser estimates of decay, waste and value for individual logs in a tree. The loss factors use computer based decay, waste and breakage factors that are applied to all logs in a tree equally and log grade algorithms that are linked to pathological indicators and historic scale. CGNF provides better tree and site specific volumes and value than the loss factor system.

The Call Grading/ Net Factoring system is designed to be consistent and auditable. The net volume principles, procedures and standards will be fine tuned through an unbiased net volume adjustment process that will be applied as post-cruise compilation factors known as species net volume adjustment factors (NVAF).

It is important that cruisers use a common set of principles, procedures and standards, so that logs are net factored and graded in a similar manner.

Net factors are applied to each log. Each loss indicator has a procedure for determining the amount of sound wood deduction for rot and missing wood in each log. The grade is the quality descriptor for each net factored log and the grades are grouped into end-use sorts for determining the selling prices. The system is based on the principle that the cruiser will always attempt to use the longest standard length within the highest sort.

Following is an example of the CGNF process:

1. Identify potential diameter limits, major form and surface characteristics.
2. Determine the sort lengths (13, 11, 8 metres) and sort length combinations that will provide the best sort per top diameter limits.
3. Inspect for any sound wood losses and use of non-standard log lengths. Calculate the net factors for the log lengths using the conventions illustrated in this manual.
4. Using the standards in this manual, assign the appropriate grade to the log.

1.1. Definitions

“**Borderline Tree**” means a tree that is at or near the limiting distance of the DBH x Plot radius factor (PRF) and the distance from plot center is measured to check if the tree will be included in a variable radius plot.

“**Breakage**” means the breakage assigned by the CGNF cruise compilation program, which is the same as the 1976 Loss Factor Breakage by species and maturity class. CGNF breakage also refers to the broken segments of tree that are graded as firm-wood reject (Z-grade) and contribute to the waste component in the cruise compilation program.

“**Breast Height**” means the location on a tree where its diameter (DBH) is measured. It is located exactly 1.3 m above "high side". If high side is lower than the point of germination (POG), breast height is 1.3 m above the POG.

“**Butt Rot**” means rot that extends from the ground into the first log (butt log) of the tree. The rot is usually conical.

“**Butt Rot Conk**” means *Phaeous schweinitzii*, which is a butt rot conk that is on the stem or ground by the nearest susceptible tree. The net factor rule is different than for heart rot conks.

“**Cat Face**” means a large scar with the inner and outer bark missing on the butt log of a tree.

“**Cambium**” means the inner bark of the tree where water and nutrients travel in the tree.

“**Charred Wood**” means that fire has penetrated the outer bark and burned the cambium and heartwood of the stem of the tree.

“**Check**” means a separation of the wood at right angles to the annual rings. Checks affect the amount of fiber available for cutting lumber (e.g. eight foot two by fours).

“**Circumference**” in the context of this manual, means the distance around the outside of the stem of tree at DBH or the mid-point of a segment of the stem (e.g. log).

“**Coast**” means the area subject to the *Coast Appraisal Manual*.

“**Cutblock**” means an area that meets the cutblock requirements as specified in the *Coast and Interior Appraisal Manuals*.

“**Cutting Authority Area**” means the area authorized to harvest Crown timber, as provided by the *Forest Act*.

“**Cutting Specifications**” mean the timber merchantability specifications as defined in the *Coast and Interior Appraisal Manuals*.

“**DBH (Diameter Breast Height)**” means the outside bark diameter of a tree measured at breast height.

“**Dead Tree**” means a tree that does not have any live cambium.

“**Decay**” means the presence of rotten wood and decay indicators that a cruiser can see and deducts from the net volume when they calculate a net factor for a log.

“**DIB (Diameter inside Bark)**” means the diameter of a tree, excluding the outer bark.

“**Felling Breakage**” means the segments of the tree stem that are less than 3m long and broken at both ends (e.g. Z-grade).

“**Fluting**” means the circumference of a tree stem has bark covered recesses. Fluting is a normal tree form and does not have any decay significance. The voids created by the recesses are not net factored (i.e. – not missing wood).

“**Fruiting Body**” means a fungus that grows on the stem of a tree or branch and is an indicator of advanced decay in a tree. Fruiting bodies are also known as “conk”.

“**Grade or Better**” means that a log must be of the grade or a grade higher in the statutory log grading hierarchy for the grade.

“**Gross Length**” means the total tree length of a tree inclusive of missing segments (i.e. – includes the length of the broken top and missing segments).

“**Gross Volume**” means the volume of a log or tree before any deductions for decay or missing wood.

“**Heart Rot Conk**” means a fruiting body (i.e. conk) of a fungus that causes decay in the heartwood of the log or tree. The following conks are eligible to apply the CGNF conk and blind conk standards for appraisal cruising:

- i. *Phellinus pini*.
- ii. *Echinodontium tinctorium*.
- iii. *Fometopsis pinicola* (i.e. only on old scars of live and dead trees).
- iv. *Phellinus igniarius* (e.g. – common on Aspen & Birch).
- v. *Phellinus tremulae* (i.e. – found only on trembling aspen).
- vi. *Phaeous schweinitzii* (i.e. – this is a butt rot conk that is on the ground by the nearest susceptible tree or on the stem. The net factor rule is different than for heart rot conks).

“**Heli-log**” means a harvest method where the trees are lifted from the harvest area by a helicopter. The cruiser may apply shorter standard log lengths to accommodate the lift capacities of the helicopter.

“**High Side**” means the position where the ground meets the tree adjacent to the highest ground, ignoring any root flare, obstacles, vegetation, and loose matter that has accumulated at the base of the tree.

“**In/Out Tree**” means a tree that is “in” or “out” of a plot based on the DBH x plot radius factor (PRF) for variable plots or the distance from the tree to plot center for a fixed area plot.

“Knot size” means the diameter of the heartwood where branches or branch stubs (i.e. not candelabras) enter the stem of the tree and does not include the bark or shoulder wood of the branch.

“Last Log” means the log at the top of the tree and it is always recorded as “99” in the log length column. The last log length is calculated by the cruise compilation program and is usually not equal to a standard log length.

“Length Deduction” means that the cruiser’s calculation converts decay or missing wood to a length (m) and deducts the length from the gross log length to calculate the net factor.

“Log Grade” means those log grades that are identified in the Scaling Regulations or CGNF Standards and Procedures for the Coast Forest Area, as appropriate.

“Loss Factor” means the method used to determine the net volume of a tree. The loss factors were determined as part of the provincial inventory system. Loss factors use a combination of tree maturity, pathological indicators and tree location (FIZ and PSYU or local factors) to determine the percentage of decay, waste and breakage that will be deducted from the gross merchantable volume equally from each log in a tree.

“Mature” means trees that are at least 141 years old. Sometimes they are known as “old growth.”

“Merchantable” means a segment of a tree that is between 30cm stump height and a merchantable top diameter inside bark as defined in the *Coast* and *Interior Appraisal Manuals*.

“Net merchantable volume” means the tree or log volume from a 30cm stump height to the merchantable top diameter minus decay, waste and breakage.

“Net Volume Adjustment Factor (NVAF)” means a factor that is applied to the net volume of each log in a tree in the CGNF cruise compilation programs. The NVAFs vary by species and whether or not the tree is alive or dead. The NVAFs are calculated by the Forest Analysis & Inventory Branch using random volume and decay samples in B.C. The NVAFs adjust for errors in the CGNF cruising standards, taper equations, hidden decay and natural voids that the cruiser cannot see or adjust for in their field assessment.

“Pencil Bucking” means the consideration that the cruiser applies when grading logs with sweep. Segments that are shorter than the standard log lengths may be used in their assessment, but the standard log length is still recorded.

“Pistol Butt” sometimes known as “hockey stick”, means that tree stem has a gradual or sudden curvature that may or not be associated with a fork or crook. Also see “Sweep”.

“Quality” means the surface characteristics of a log pertaining to knot size and frequency and spiral grain as they affect the grade of the log.

“Saprot” means the presence of decay that has penetrated beyond the outer bark and into the tree stem. Saprot is common on dead trees where it often affects the whole circumference of the tree and sap rot fruiting bodies (i.e. slash conks) are often present on the stem.

“Sawlog, Gang or Utility Log” generally means a log that is long enough and of sufficient quality to produce at least a construction grade 2”x 4” that is 8 feet long (i.e. – X-grade or better).

“Second Growth” means trees that are less than 141 years old.

“Slab” means a log segment that has broken longitudinally from a tree and has square, rectangular, triangular or rhomboid shapes. Slabs must meet minimum thickness and width standards for specific grades. Red cedar slabs are commonly graded as shingle grades.

“Sort” means an aggregate of log grades that exhibit similar size and quality characteristics.

“Stump Height” means the contractual height on the stem from the high side ground from which trees may be felled. The timber merchantability specifications prescribe a 30cm stump height for timber cruising, appraisal and billing purposes.

“Sweep” means that a tree has a curvature along the stem that is not necessarily associated with a fork or crook. Sweep is a grade consideration and can be pencil bucked as per the CGNF standards.

“Twist” means the wood grain of a log spirals around the center axis of the log. It is also known as “spiral grain”.

“Waste” means the firm-wood reject (Z-grade) segments of the tree.

1.2. Definitions

Each net factor calculation will be calculated using at least three decimal places and the final net factor will be reported to the nearest whole number on the cruise tally card. (i.e., digits 0-4 are rounded down and 5-9 are rounded up).

For example, meeting a net factor or grade consideration threshold:

- $74.509 = 75$ and meets the 75% cut threshold
- $74.409 = 74$ and does not meet the minimum 75% cut threshold

For quality assurance thresholds, calculations will be rounded to the nearest tenth. For example, meeting a standard for a check cruise volume or value variation:

- $10.041 = 10.0$ and does not exceed 10.0%
- $10.051 = 10.1$ and exceeds 10.0%

1.3. Call Grading and Net Factoring

Call grading and net factoring are processes used to assess timber quality and net tree volume. The processes do not attempt to predict grade based on anticipated falling breakage or the manufacturing process, or to predict volume loss without direct evidence. The loss factor breakage percentages are used in the cruise compilation.

1.3.1. Call Grading

Call Grading is a procedure that assigns a descriptor grade each log on a tree. Call grading and net factor standards will determine the length of the log.

The process is hierarchical. The cruiser selects the highest "sort" that the tree will support. The standard sorts are lumber, peeler, **high grade sawlog, mid grade sawlog, shingle**, gang, utility, pulp and non-recoverable.

The cruiser then selects the first grade within the sort which will provide the longest standard log length. Standard log lengths are 13, 11 and 8 metres. For example, the lumber sort has three grades for some species (D, F, B). If the tree will support a 13 metre "F", but only an 8 metre "D" then the log will be a 13 metre "F".

The log lengths can be either "standard" or "variable". For the determination of standard lengths the cruiser attempts to assign the longest allowable standard length for a grade in the highest sort. Logs will normally not be longer or shorter than the standard lengths. Variable lengths are allowed for the occurrence of poor tree form and/or severe defect and/or unique grade considerations. See [Table 1](#).

1.3.2. Net Factoring

Net Factoring is a procedure whereby the cruiser assigns a net factor (% sound) to the log that is being graded. The principle for the net factoring procedures is to measure any rot or missing wood directly and reduce the log volume percent sound-wood remaining. If the rot or missing wood cannot be directly measured, then a set of standard procedures for each defect is applied. No other deductions are made for local knowledge.

Deductions normally measured directly are:

- Butt rot (when visible),
- Missing wood (scars, burns, etc.), and
- Sap rot.

Deductions normally determined by applying a procedure are:

- Conk,
- Blind conk,

- Rotten branches,
- Root rot,
- Rot in forks,
- Crooks,
- Broken tops,
- Frost cracks, and
- Soundings

The net factors that are used to assign the net merchantable volume will be further adjusted by a series of net volume adjustment factors (NVAF) in the compilation program.

Table 1 Summary of Sorts, Grades, Standard Log Lengths and Application Notes

The following end use sorts, grades and standard lengths will be used:

SORT TYPE	GRADE	STANDARD LENGTHS (m)	NOTES
Lumber	D,F,B,G	13,11,8	Min length 5 m
Peeler	C	13,11,8	Min length 5 m
High Grade Sawlog	H	13,11,8	Min length 5 m
Mid Grade Sawlog	I	13,11,8	Min Length 5 m
Shingle	K,L,M	13,11,8	Min length 4 m, 1 m multiple up to 13 m / attempt to use standard lengths.
Gang	J	13,11,8	Min length 5 m
Utility	U,X	13,11,8	Min length 5 m
Pulp	Y	13,11,8	Min length 3 m, 1 m multiples up to 13 m / attempt to use standard lengths.

Log lengths of 4 and 6 m are allowed for all sorts for helicopter logging only. (See [Table 2](#))

NON SORT	GRADE	STANDARD LENGTHS (m)	NOTES
Breakage	Z Shatter and non-recoverable	1 m multiples	Z grade is not intended to meet the statutory definition of firmwood reject.
Missing Wood	N	1 m multiples	Net Factor = "00"

1.3.3. Tree Form

Irregular tree forms such as forks/crooks/pistol butts may necessitate the use of non-standard log lengths. Pencil bucking Y or Z-grade segments is acceptable if the tree form will affect the standard log length and/or sort. See [Figure 1.1](#) where tree form affects the standard log lengths. Sweep in deciduous trees may not change the sort or the standard length provided that the effect of the sweep can be removed by pencil bucking the log in 2.5 m increments.

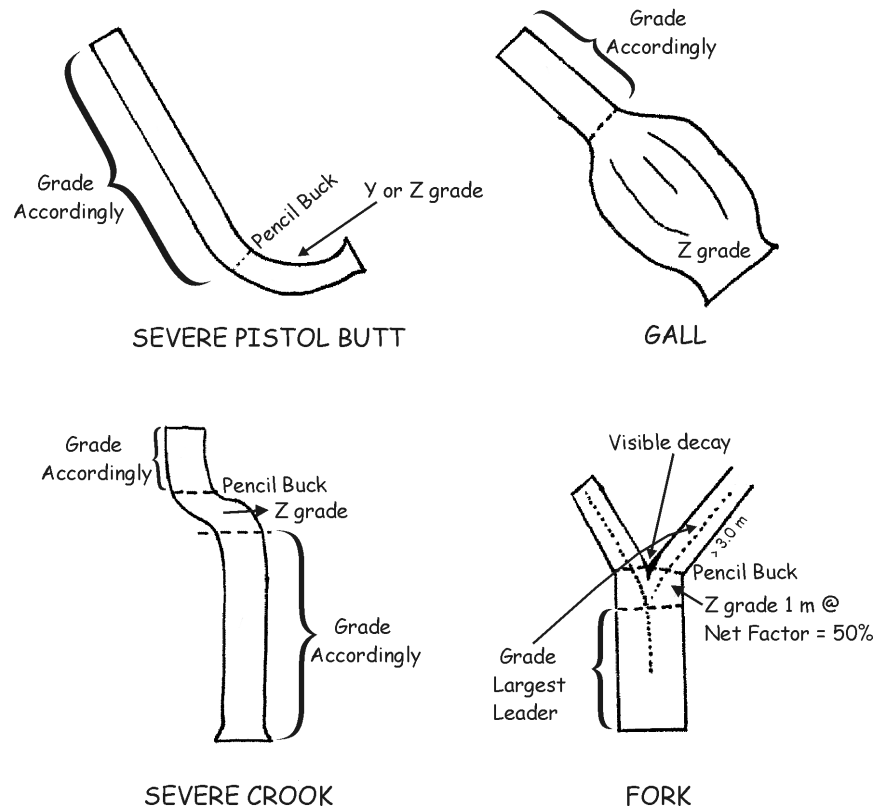

Figure 1-1 Irregular Tree Form

Major defects may necessitate non-standard log lengths.

Shingle cedar can be 4 metres to 13 metres and 1 metre increments to accommodate excessive decay and bark seams.

Helicopter log lengths are per weight restrictions. The 4 and 6 metre lengths can only be used in cutblocks identified as helicopter logging on the cruise plan.

Table 2 Helicopter log lengths to be used based on estimated top DIB

Estimated Log Top DIB (centimetres)	Log Lengths				
	1 st Log	2 nd Log	3 rd Log	4 th Log	5 th Log
<75.0	13, 11, 8	13, 11, 8	13, 11, 8	13, 11, 8	13, 11, 8
75.0 – 100.0 cm	8	13, 11, 8	13, 11, 8	13, 11, 8	13, 11, 8
100.0 – 149.9 cm	6	8	13, 11, 8	13, 11, 8	13, 11, 8
150.0 – 200.0 cm	4	6	8	13, 11, 8	13, 11, 8
>200 cm	4	4	6	8	13, 11, 8

The last log in a tree will almost always have a non-standard length and so it is always coded as a "99". The computer calculates the last log length based on the taper equation and merchantable top diameter.

Fallen trees with roots attached will have a 1 metre Z grade for the first log if they are < 100 cm at DBH and a 2 metre Z grade if they are > or = 100 cm at DBH.

1.4. Conventions/Procedures for Call Grade Net Factoring

- a. A dead tree (or dead piece of a tree) is tallied if it contains a log 8 metres or more in length and has a grade of U or better. **Assess the first intact 8m log that starts after pencil bucking of root balls, breaks, shatter, missing wood or chainsaw cuts. If the above condition is met, then the whole tree must be tallied and call grade net factored.**
- b. The primary objective is to have logs in the correct end use sort. Grades within the sort are a secondary objective.
- c. The grades and the grading rules are modifications of the statutory log grading rules and are not intended to match statutory grading rules and logic.
- d. The standard lengths are 13, 11 and 8 metres (See Table 1).
- e. Specified helicopter operations have the additional options of 6 metres and 4 metres (See Table 2).
- f. Shingle lengths are a minimum of 4 metres increasing in 1 metre increments up to 13 metres (See Table 1).
- g. Pulp (Y grade) lengths are in increments of 1 metre. Attempt to use standard log lengths where possible (See Table 1).
- h. Grade Z is used for non-recoverable and shatter and grade "N" is used for nothing there (missing wood) (See Table 1).
- i. The last log in a tree is described by "99" to indicate that the sort runs to the top of the tree.
- j. Ring shake is recognized for all species except Cedar and Cypress. See Section 3.2.3.12 for situations where ring shake can be considered:
- k. Butt logs with ring shake cannot be in peeler or lumber sorts. In general, ring shake should be isolated by using an 8 metre butt log.
- l. Windfall trees (with their roots attached) up to 100 cm DBH will have a 1 meter "Z" grade in the butt log.
- m. Windfall trees (with their roots attached) over 100 cm DBH will have a 2 metre "Z" grade in the butt log.
- n. Standard procedure-based deductions will be used to determine the extent of the defect and the net factor calculation (% sound wood).
- o. Pencil bucking is used to section the tree into maximum standard log lengths by sort. Pencil bucking is used for tree shape (e.g. forks, pistol butt) as well as extreme decay or missing wood. A grade is assigned and the log is net factored.
- p. Net factoring is only used for sound wood loss that is caused by decay or missing wood.

- q. If it is necessary to calculate log volumes the convention will be to use DBH for the butt log diameter and the estimated mid-point diameter for logs above the butt log.
- r. Sounding will be used to assess the presence of hidden butt rot. If a hollow sound is detected, a 0.8 m length deduction is removed from the butt log. Sounding cannot be applied if there is any visible rot or net factor procedure that affects the tree below 2.4 m.

It is recommended that an “S” is painted on the tree where the sounding is heard. If there are safety concerns for cruisers or licensees, then do not sound the tree(s).

- s. The species codes are required for mountain hemlock (Hm) and western hemlock (Hw or H) because they have separate NVAFs. A tree recorded as H will always default to the western hemlock NVAF.

2. Net Factoring

2.1. Net Factoring Process

1. In conjunction with the end use sorts, standard log lengths and cruiser call grading rules, determine the applicable log lengths for each tree to the nearest whole metre.
2. Using measurements and procedure-based deductions, calculate the net volume expressed as a net factor for each log section.
3. Loss indicators that extend below ground level are considered in the net factoring process.

For example, a frost crack that extends from minus 0.5 to plus 1.5 is calculated as a 2.0 metre frost crack. The loss is applied to the first log. Similarly a root rot conk present on the ground is applied to the first log.

4. Assign a net factor to each log. If the log has no measurable sound wood loss then the net factor is 100%. Record the net factor as two dashes (--).
5. Note that direct volume "measurement" deductions (net factoring) by log are made where the decay or missing wood is both visible and physically measurable. See [Section 1.3.2](#) for situations where deductions are either directly measured or determined procedurally.

2.2. Net Factoring Deductions

Net factoring deductions for this manual will normally be expressed as length deductions. The net log length expressed as a percent of the gross log length represents the net factor in percent. For example, an 8.0 metre log may have a 0.8 m deduction due to rot. The net factor is 90% because 10% of the log length is rotten $(7.2/8.0) \times 100 = 90\%$.

Some situations may require lookup tables or log volume calculations.

Logs are considered cylinders for log volume calculations and decayed portions may be rectangular (e.g. scars), cylindrical (e.g. conks) or conical (e.g. butt rot). The following conventions and formulas shown in Table 3 will be used in the calculations:

Diameter: length of a straight line passing through the centre of a circle.

Radius(R): line extending from the centre of a circle to the circumference ($\frac{1}{2}$ diameter).

Table 3 Formula for Calculating Volume

Shape	Formula
Cylinder	Volume = $\pi R^2 * L$
Cone	Volume = $(1/3) \pi R^2 * L$
Rectangular solid	Volume = Length * Width * Depth
Units must be consistent (all cm or all m).	

2.2.1. Applying Deduction Rules

Table 4 Summary of Procedures for Determining Net Factor for Loss Indicators

Defect	Form	Method	Deduction Area	% Sound or Length Deduction Area	Grade
Heart Rot Conk	Cylindrical	Procedure	2 m above conk 4 m below conk	50%	Y
Blind Conk	Cylindrical	Procedure	4 m above conk 6 m below conk	50%	Y
Rotten branch	Cylindrical	Procedure	1 m above	1.0 metre	Z

Defect	Form	Method	Deduction Area	% Sound or Length Deduction Area	Grade
			1 m below		
Butt rot/Cat face	Conical	Calculate	extent of scar	calculated	assigned*
Root rot (fruiting body on ground)	Conical	Procedure	3 m	0.6 metres	assigned*
Sounding	Conical	Procedure	0.8 m length deduction	calculated	assigned*
Scar	Rectangular	Calculate	extent of scar	calculated	assigned*
Frost crack	Other	Procedure	extent of frost crack	0.1 m per lineal metre of frost crack	assigned*
Fork	Other	Procedure	if decay present: 1 m below	0.5 metre	Z
Crook	Other	Procedure	if decay present: 1 m below	0.5 metre	Z
Dead top	Other	Calculate	live crown to top of tree	Net Factor = 85% if can't be measured	assigned*
Broken top	Other	Procedure	broken off portion if decay present: 1.0 m below break	00 1.0 metre	N assigned*
Direct Observation	Other	Procedure	various	calculated	assigned*
* Assigned by cruiser in the field based on surface characteristics and decay percentage.					

2.3. Deduction Procedures for Loss Indicators

2.3.1. Heart Rot Conk

The standard is that conk rot extends 2 m above the conk and 4 m below it. This creates a 6 m pulp log (Y grade) with a net factor of 50% (3m/6m).

For example, a tree with 22 m of sawlog quality and a conk at 12 m could be pencil bucked as a sawlog for 8 m, pulp (Y grade) for 6 m (net factor 50%), then sawlog for 8 m.

Table 5 Deduction Procedure for Heart Rot Conk

Form	Cylindrical
Method	Procedure
Deduction area	2 m above conk; 4 m below
% Sound of deduction area (net factor)	50% or 3 metre length deduction
Grade	Y

Formula

$$\text{Net Factor} = (\text{Net Log Length} / \text{Log Length}) \times 100\%$$

$$\text{For example: } (6.0 - 3.0) / 6.0 \times 100 = 50\%$$

For multiple conks, decay is assumed to extend 2 m above the top conk and 4 m below the lowest conk. The connected length is given a net factor of 50% and a grade of Y.

Do not overlap conk and blind conk deductions as they are not cumulative. The net factor can be less than 50% if there are other indicators associated with a conk or blind conk segment. The net factor can be greater than 50% if conk segments with less than 5 m between them are combined into one Y grade log. (See [Figure 2.12](#))

Fomitopsis pinicola is only considered a heart rot for this procedure when it is on large old scars on live trees. See the *Cruising Manual* Appendices for descriptions of the heart rot conks.

2.3.2. Root Rot

All root rots are assumed to be conical in nature. Unless otherwise observed, the standard procedure is that the cone of rot extends 3 m from the ground and that the ratio of the diameter of the rot to the diameter of the butt is 75% ($\frac{3}{4}$).

The length deduction for the 3 metre section is 0.6 metre. If the fruiting body is located on the stem, then the butt rot length will be based on a cone that extends 3 metres above the highest fruiting body and the base of the cone will be a $\frac{3}{4}$ ratio.

Table 6 Deduction Procedure for Root Rot

Form	Conical
Method	Standard
Deduction area	0 - 3 m
Length deduction	0.6 m (if fruiting body is on the ground)
Grade	Assigned

Formula

$$\text{Net Factor} = (\text{Net Log Length}) / \text{Log Length} * 100\%$$

EXAMPLE
Log length: 8 m; Rot extends: 3 m
$\text{Net Factor} = (8 \text{ m} - 0.6 \text{ m}) / 8 \text{ m} \times 100$ $= 7.4 \text{ m} / 8 \text{ m} \times 100$ $= 93 \%$

Figure 2-1 Example of Net Factor Calculation for Root Rot on the Ground

If *Phaeolus Schweinitzii* butt rot is encountered, the net factoring process will apply the loss as a root rot [0.6 metre length deduction]. If the conk is on the stem, use the calculation demonstrated in [Figure 2.2](#) or apply a 19% reduction from the height of the conk on the stem plus 3 m.

In the example in [Figure 2.2](#) using an 8 m log, the deduction is: $0.19 \times 6 \text{ m} = 1.1 \text{ m}$.

Therefore, the net factor is: $(8 \text{ m} - 1.1 \text{ m}) / 8 \text{ m} = 0.86$ (86%)

Note that a cone is 1/3 of the volume of a cylinder.

EXAMPLE

Fruiting body 3 m up the stem, therefore cone of rot extends 6 m up the stem.

Log length = 8 m, $\frac{3}{4}$ ratio conical rot extends 6 m, DBH: 100 cm

$$\begin{aligned} \text{Deduction} &= \left(\frac{3}{4}\right)^2 \times 6\text{m}/3 \\ &= 1.1 \text{ m} \end{aligned}$$

$$\begin{aligned} \text{Net Factor} &= (8\text{m} - 1.1\text{m})/8\text{m} \times 100 \% \\ &= \mathbf{86 \%} \end{aligned}$$

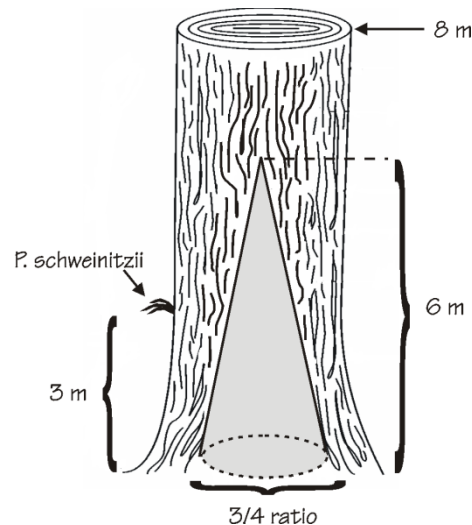

Figure 2-2 Example of Net Factor Calculation for Root Rot on the Tree

2.3.3. Blind Conk

Coastal zone: typically the cambium is collapsed.

Table 7 Deduction Procedure for Blind Conk

Form	Cylindrical
Method	Procedure
Deduction area	4 m above conk 6 m below
% Sound of deduction area (net factor)	50% or a 5 metre length deduction.
Grade	Y

Formula

$$\text{Net Factor} = (\text{Net Log Length} / \text{Log Length}) \times 100$$

EXAMPLE

Log length = 11 m, blind conk at 7 m

$$\text{Net factor} = (11 \text{ m} - 5 \text{ m}) / 11 \text{ m} \times 100\% = 54 \%$$

2.3.4. Frost Crack

Table 8 Deduction Procedure for Frost Crack

Form	Other.
Method	Procedure.
Deduction area	Log.
% Sound of deduction area (net factor)	0.1 metre deduction for each 1 m of frost crack in log.

Grade	Assigned.
-------	-----------

Frost crack(s) that run across the grain of the log (i.e. spiral cracks) will result in a loss of merchantable volume and lower sort and/or grade.

Formula

Net Factor = (Net Log Length/Log Length) x 100%

For the example below: $(11.0 \text{ m} - 1.4 \text{ m})/11.0 \text{ m} \times 100\% = 87\%$

EXAMPLE	
Log length: 11 m;	
Two frost cracks are located as follows:	6 m long (from 0 m to 6 m) 8 m long (from 3 m to 11 m)
Deduction = $0.1 \times (6\text{m} + 8\text{m}) = 1.4 \text{ m}$	
Net Factor = $(11.0 \text{ m} - 1.4 \text{ m})/11.0 \text{ m} \times 100\%$	
Net Factor = 87%	

Figure 2-3 Example of Net Factor Calculation for Frost Cracks

2.3.5. Scar

Table 9 Deduction Procedure for Scar

Form	Rectangular
Method	Calculate
Deduction area	Extent of scar
% Sound of deduction area (net factor)	Calculated
Grade	Assigned

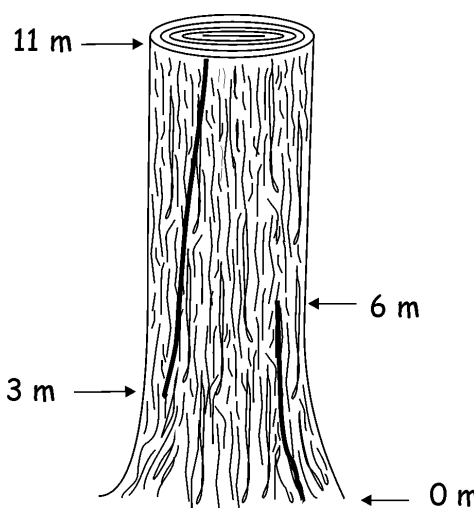
Procedure #1 - When depth of rot can be measured and expressed as a rectangle.

Butt scars can often be measured and expressed as a rectangle. Note that this procedure uses volume as a deduction rather than length.

Formula

$$\text{Net Factor} = (\text{Net volume of Log}) / (\text{Gross Volume of Log}) * 100\%$$

$$\text{For the example below: } (8.42 \text{ m} / 8.64 \text{ m}) * 100\% = 97\%$$

Assume the scar is rectangular:

$$\text{Decay volume} = \text{length} * \text{width} * \text{depth}$$

Assume the log is cylindrical (diameter at DBH for butt logs, midpoint diameter for other logs):

$$\text{Log volume} = \pi * \text{radius}^2 * \text{length}$$

A net factor less than 95% is rare for a scar.

EXAMPLE

Log length: 11 m; diameter: 100 cm

Scar: length 11 m, width 20 cm, depth 10 cm

1. Volume of Decay = $L * W * D$ (volume of rectangle)
= $11 \text{ m} * 0.2 \text{ m} * 0.1 \text{ m}$
= 0.22 m^3

2. Volume of Log = $\pi R^2 L$ (volume of cylinder)
= $\pi * (0.5 \text{ m})^2 * 11 \text{ m}$
= $3.14 * 0.25 \text{ m}^2 * 11 \text{ m}$
= 8.64 m^3

3. Net Factor = $(8.64 \text{ m}^3 - 0.22 \text{ m}^3) / 8.64 \text{ m}^3 * 100\%$
= $8.42 \text{ m}^3 / 8.64 \text{ m}^3 * 100\%$
= 97.454 - closer to 97%

Procedure #2 - Rot is visible but cannot be easily converted to a rectangular form or cannot easily be measured. This is a length deduction rather than the previous volume deduction.

Formula

Net Factor = (Net Log Length/Log Length) x 100%

For the example below: $(12.4 \text{ m} / 13.0 \text{ m}) * 100\% = 95\%$

1. Estimate width and measured length of scar on log.
2. Calculate circumference of log at the scar ($\pi * D$).
3. Calculate "length" deduction = (width of scar/circumference of log) x scar length.
4. Net Factor = (net log length/original log length) x 100.

EXAMPLE	
Log length: 13 m; diameter: 100 cm	
Scar: length 11 m, width 20 cm, depth pie shape to pith	
1. Circumference = $\pi \times D = 314$ cm	
2. Width of scar = 20 cm	
3. Scar proportional circumference (pc) = 20 cm/314 cm = 0.06	
4. Length deduction = Length of scar x pc = 11m x 0.06 = 0.7 m	
5. Net Factor = $((13\text{m} - 0.7\text{m}) / 13) \times 100$ = 95%	

Figure 2-4 Examples of a Net Factor Calculation for Scars with Known Depth

2.3.6. Butt Rot/Cat Face

Cat face is normally a "dry side" without rot. It is usually net factored the same as a scar. If the cat face is rotten then it is treated as butt rot.

Table 10 Deduction Procedure for Butt Rots

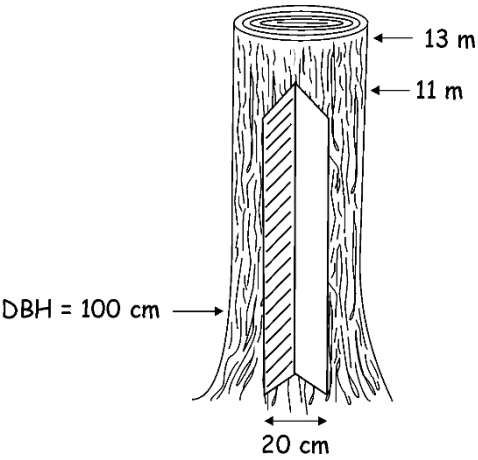
Form	Cylindrical/Conical
Method	Calculate
Deduction area	Extent of Scar
% Sound of deduction area (net factor)	Calculated
Grade	Assigned

There are three methods of dealing with this form of internal decay:

Procedure #1 - Cylindrical Defect of Known Length

Formula

$$\text{Net Factor} = (\text{Net Log Length}/\text{Log Length}) \times 100\%$$

For the example below: $(7.3 \text{ m}/13 \text{ m}) \times 100\% = 56\%$

EXAMPLE	
Log length: 13 m; Cylindrical butt rot length; 12 m	
Diameter = 80 cm and rot 55 cm	
Deduction length = $(55 \text{ cm}/80 \text{ cm})^2 \times 12 \text{ m} = 5.7 \text{ metres}$	
Net Factor = $(13.0 \text{ m} - 5.7 \text{ m})/13 \text{ m} \times 100$	
= 56%	
	

Figure 2-5 Example of Net Factor Calculation for Cylindrical Defect

Procedure #2 - Conical Defect of Known Length

Formula

$$\text{Net Factor} = (\text{Net Log Length}/\text{Log Length}) \times 100\%$$

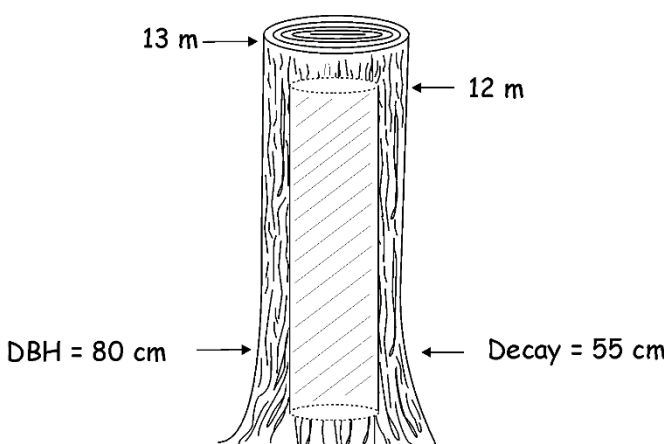
For the example below: $(11.1 \text{ m}/13 \text{ m}) \times 100\% = 85\%$

Note that a cone is 1/3 of the volume of a cylinder.

EXAMPLE

Log length: 13 m; conical butt rot length; 12 m

Diameter = 80 cm and rot 55 cm

$$\text{Deduction length} = (55 \text{ cm}/80 \text{ cm})^2/3 \times 12 \text{ m} = 1.9 \text{ metres}$$

$$\text{Net Factor} = (13.0 \text{ m} - 1.9 \text{ m})/13 \text{ m} \times 100$$

$$= 85 \%$$

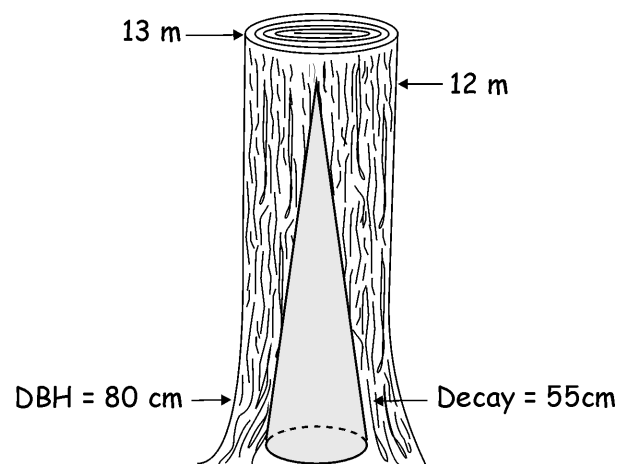

Figure 2-6 Example of Net Factor Calculation (conical)

Procedure #3 – Conical Defect of Unknown Length for Cedar Shingle Butt Logs Less Than 8m Long and the Rot in the Butt Log is Cylindrical

EXAMPLE	
Log #1 length: 4 m; cylindrical butt rot length unknown	
Diameter = 80 cm and rot 55 cm	
Log #2 length: 13m, use $\frac{3}{4}$ ratio on this log (55 cm/80 cm) = 1.2 m length deduct from <u>Table 11</u>	
Log #1	Deduction = $(55 \text{ cm}/80 \text{ cm})^2 \times 4 \text{ m} = 1.9 \text{ m}$ Net Factor = $(4.0 \text{ m} - 1.9 \text{ m})/4.0 \text{ m} \times 100\% = 53\%$
Log #2	Net Factor = $(13.0 \text{ m} - 1.2 \text{ m})/13 \text{ m} \times 100 \% = 91 \%$
<p>The diagram shows a vertical log with a conical defect (rot) at the top. The total length of the log is 17 m. The diameter at the top is 80 cm (DBH). The diameter of the cylindrical rot at the stump height is 55 cm. The length of the rot is 4 m. The log is divided into Log 1 (4 m) and Log 2 (13 m).</p>	

Figure 2-7 Example of Net Factor Calculation (cylindrical & conical) for Cedar Shingle

Procedure #4 - Conical Defect of Unknown Length (See Table 11)

Formula

$$\text{Net Factor} = (\text{Net Log Length}/\text{Log Length}) \times 100\%$$

If the extent or length of rot is unknown, the deduction is based on the ratio of the diameter of rot at stump height to the DBH. Figure 2.5 – 55 cm/80 cm = approx. $\frac{3}{4}$.

From Table 11 (length deduction for $\frac{3}{4}$ 1.2 metres)

$$\text{Net factor} = (13.0 \text{ m} - 1.2 \text{ m})/13 \text{ m} \times 100 = 91 \%$$

1. Find the ratio (diameter of decay/DBH)
2. Use Butt Rot table for ratio of butt rot.
3. Determine the nearest ratio and apply the length deduction.
4. Net down the log length and express the net factor as a percent of the original length.

Butt rot is generally included with the log for its maximum sort length.

The Butt Rot Guide (Table 11) gives the conical butt rot ratios by log length. Note that the grade consideration in the table and surface characteristics of the log will determine the sort. Deductions and grade considerations are based on diameter of rot at stump height/DBH ratio. Calculate the ratio to the nearest ¼ diameter, determine the length deduction from the table below, and calculate the net factor. The rot diameter is measured at the stump height.

Table 11 Butt Rot Guide for Length Deductions

Ratio	Net Factor Length Deduction (volume loss)	Grade Consideration* (length not available for manufacture)
¼ diameter	0.2 m	0.6 m
½ diameter	0.4 m	1.8 m
¾ diameter	1.2 m	3.6 m
4/4 diameter	2.4 m	4.2 m
Sounding	0.8 m	2.4 m
P. schweinitzii	0.6 m	2.0 m
<p>For lumber, sawlog and utility sorts, grade consideration denotes the loss of lumber in the log and describes the portion not available to produce 2 by 4's at least 8 feet long. For pulp and shingle sorts, butt rot grade consideration is equal to the net factor length deduction.</p>		

EXAMPLE	
The butt rot length is not visible, therefore we need a process to determine deduction length.	
Rot diameter = 55 cm; DBH = 100 cm; log length = 11 m	
Ratio = rot diameter/log diameter = 55 cm/100 cm=1/2	
The deduction is 0.4 m length (from Table 11).	
Net Factor	= (11 m - 0.4 m)/11 m
	= 96%

Figure 2-8 Example of Net Factor Calculation (using butt rot table)

Sounding

Sounding will be used to assess the presence of hidden butt rot. If a hollow sound is detected, a 0.8 m deduction is removed from the butt log. Sounding cannot be applied if there is any visible rot or net factor procedure that affects the tree below 2.4 m.

Formula

EXAMPLE	
Net Factor	= (Net Log Length/Log Length) x 100%
	= (13 m – 0.8 m)/13 m x 100
	= 94%

Figure 2-9 Example of Sounding Deduction

2.3.7. Fork

In general, a fork only becomes a bucking point if there is significant enough offset in the log that will prevent the cutting of lumber. If the fork is severe, it may be bucked out in one-metre lengths as "Z" grade. If there is rot in the fork, it will be net factored.

Table 12 Deduction Procedure for Fork with Visible Decay

Form	Other
Method	Procedure
Deduction area	1 m below
% Sound of deduction area (net factor)	50%
Grade	Z

2.3.8. Crook

In general, a crook only becomes a bucking point if there is a significant enough offset in the log that will prevent the cutting of lumber. If the crook is severe, like a severe pistol butt for example, it may be bucked out in one-metre lengths as "Z" grade. If there is rot in the crook, it will be net factored.

Table 13 Deduction Procedure for Crook with Visible Decay

Form	Other
Method	Procedure
Deduction area	1 m below
% Sound of deduction area (net factor)	50%
Grade	Z

2.3.9. Rotten Branch

Table 14 Deduction Procedure for Rotten Branch with Visible Decay

Form	Cylindrical
Method	Procedure
Deduction area	1 m above the rotten branch; 1 m below
% Sound of deduction area (net factor)	50%
Grade	Z or assigned

For multiple, overlapping rotten branches/knots (i.e. less than 2 m apart), deduction extends 1 m above and below the series of rotten branches/knots.

2.3.10. Dead Tops

(Broken tops are handled separately.)

Rot must be visible before a net factor can be applied. Rot is treated as sap rot. If the decay is not measurable (e.g. at the top of the tree), apply a net factor of 85% to the rotten portion. The 85% standard does not apply to tops that are on the ground and can be measured. If it can be measured, use the following procedures:

Formula

$$\text{Net Factor} = (\text{Net Log Length} / \text{Log Length}) \times 100\%$$

$$\text{For the example below: } (6.9 \text{ m} / 8.0 \text{ m}) \times 100\% = 86\%$$

Table 15 Deduction Procedure for Measurable Sap Rot

Form	Other
Method	Calculate
Deduction area	From top of live crown to tree length
% Sound of deduction area (net factor)	Calculated
Grade	Assigned

Weather checked wood may affect the sort, but will not affect the sound wood content (net factor).

EXAMPLE

Midpoint diameter 20 cm, Length of rot 3 metres, Top log length 8 metres
 2 cm depth of sap rot (= 16 cm of sound wood)
 Sound wood length $(16 \text{ cm}/20 \text{ cm})2 \times 3 \text{ m} = 1.9 \text{ metres}$
 Length Deduction = $3 \text{ m} - 1.9 \text{ m} = 1.1 \text{ metres}$
 Net Factor = $(8.0 \text{ m} - 1.1 \text{ m})/8 \text{ m} \times 100 = 86 \%$

Figure 2-10 Example of Net Factor Calculation for Measurable Sap Rot

2.3.11. Broken (Missing) Tops

The tree is graded and net factored to the broken top (pencil buck at the break). The missing portion is graded as “N” with a net factor of “00” (no sound wood). Record the length of the tree in the tree height column.

Table 16 Deduction Procedure for Broken Tops

Form	Other
Method	Procedure
Deduction area	from break to original top
% Sound of deduction area (net factor)	00 = no sound wood (length = 99)

Grade	N (nothing)
-------	-------------

If a top cannot be assigned to a tree, it is treated as a separate piece for "in/out" procedures and is graded uniquely.

If a top is found on the ground and can be assigned to a tree, attach it to that tree as a log and assign a grade and net factor.

Table 17 Deduction Procedure for Rot Associated with Log Below Broken Top

Form	Other
Method	Procedure
Deduction area	1 m below the break
% Sound of deduction area (net factor)	Calculated
Grade	Assigned

Visible rot is assumed to run 1 m below the break.

Formula

$$\text{Net Factor} = (\text{Net Log Length} / \text{Log Length}) \times 100\%$$

EXAMPLE
Last log length is 10 m up to a broken top with visible decay. Net Factor = $((10 \text{ m} - 1.0 \text{ m}) / 10 \text{ m}) * 100\% = 90\%$, followed by a "N9900".

Figure 2-11 Example of Net Factor Calculation for Broken Tops with Decay

2.3.12. Fallen Trees

Fallen trees with their roots attached will have a 1 metre Z-grade for the first log if they are < 100.0 cm at DBH and a 2 metre Z-grade if they are > or = to 100.0 cm. This standard is applied to account for safety and/or machine practices.

The following procedure will be used to record whether the tree is standing or fallen:

- Standing - in the down tree column (63), code blank: trees that are self-supporting (that is, the tree would remain standing if all supporting materials were removed).
- Fallen - in the down tree column (63), code E or G. Refer to of the Appendices in the *Cruising Manual*.
- If the tree has been mechanically or hand felled, the 1 m or 2 m Z grade bucking allowance does not apply.

2.3.13. Multiple Defects

In general, the assignment of net factors to trees with multiple defects is left to the professional judgement of the cruiser.

Net factors less than 50% will only occur with severe:

- cylindrical butt rot,
- sap rot,
- missing wood, or
- conk or blind conk segments accompanied by other indicators. (Do not double call overlapping conk and blind conk segments.)
- Sound sections 5 m or longer between defects may be treated as separate logs. If sections that are 5 m or longer are a different sort, they must be treated as separate logs. Sound segments less than 5 m are included with the adjacent log segment(s). See [Figure 2.9](#).

EXAMPLE

Conk at 12 m and 20 m. This creates a 2 m section that is 100% sound between the defect areas, so we can combine all three sections into one log.

Segments = conk segment from 8 m to 14 m (6 m at 50% deduction or 3 m); sound segment from 14 m to 16 m (2m at 0% deduction); conk segment from 16 m to 22 m (6 m at 50% deduction or 3 m).

Combined segments = 22 m – 8 m = 14 m log

Grade (all 3 sections) = Y

Net Factor = (length of log - length of ded.)/length of log * 100%
 = (14 m- 3 m – 0 m – 3 m)/14 m * 100%

Net Factor = 57%

Note: The same procedure should be used whenever grade is assigned, particularly for butt rot and/or cat face.

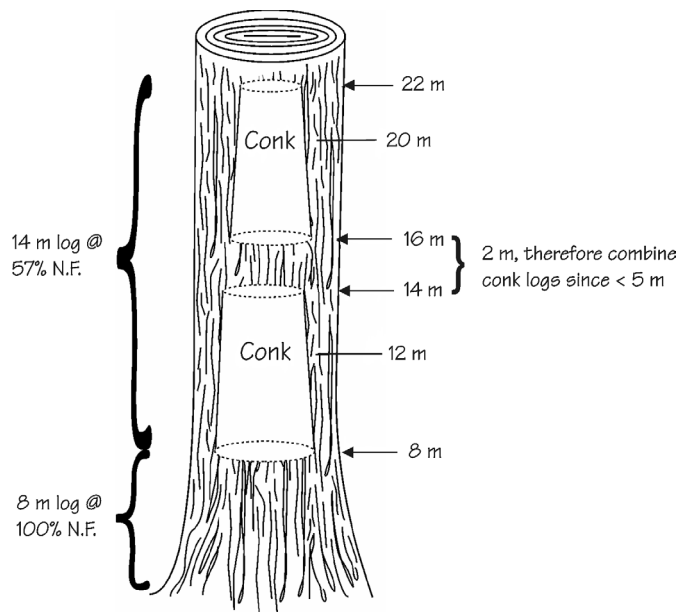

Figure 2-12 Example of Isolated Sections between Defects

If the upper conk were at 23 m, it would create a 5 m log between the two defects. This log would be treated as a separate sound log with its own grade. This would create three separate logs, each with its own grade and net factor.

2.3.14. Dead Standing and Dead Fallen Trees

- a. Dead Trees – dead trees do not have any live cambium at DBH.
- b. A dead tree is tallied if it contains a log 8 metres or more long and has a grade of U or better. **Assess the first intact 8m log that starts after pencil bucking of root balls, breaks, shatter, missing wood or chainsaw cuts.** If there is at least an 8 metre U grade log, record all of the logs in the tree.
- c. Dead fallen trees must have at least 8 metres of U grade after the 1 m or 2 m Z-grade segment.
- d. Dead fallen and dead standing trees that have a shattered (Z grade), broken or cut butt will commence with **the assessment of the first intact 8 metre long section** after the break, shatter or cut end.
- e. If down trees have been mechanically or hand felled, the 1 m or 2 m Z-grade bucking allowance does not apply (see Section 2.3.12).

3. Call Grading

3.1. Introduction

This section outlines the steps needed to assess the quality of measured trees.

3.2. Definitions

Call grading is the procedure used to assign one of the modified coastal log grades to standing and fallen timber based on the hierarchical log sorts. Grading is a hierarchical process based on the scaling conventions using top diameter inside bark, knot size (location and distribution) as well as the percentage of recoverable or sound wood available for cutting.

3.2.1. Procedures

1. The cruiser will be able to grade the log into the appropriate log sort. The **heiracrchy of log sorts in descending order** are lumber, peeler, **high grade sawlog**, **mid grade sawlog**, **shingle gang**, utility and pulp.
2. Logs are assigned to sorts, the maximum standard log length is selected and then graded based on size, quality, sound wood recoverability and merchantability.
3. Grades are assigned using the hierarchy of grades within a sort. Start with the longest standard log length for the highest grade in the sort. If the standard log length for any of the sort grades cannot be accommodated, then use the next lower sort.
4. A log cannot be “one sort or another”. It is not a choice of market preference, current harvesting practices, accessibility, or other factors. A log is the highest grade it qualifies for within the hierarchy.
5. ALL trees (live or dead, standing or fallen) will be call graded and net factored.
6. All sawlog grades must be at least 5 metres long and Y-grade must be at least 3 metres long.
7. Record whether the tree is alive (L) or dead (D).
8. Record whether the tree is mature (M) or second growth (S).
9. Grade consideration is applied by the cruiser to determine the percentage of soundwood available for manufacturing. It includes deductions for rot, missing wood and surface characteristics as well as wood unavailable due to defect shape or characteristics. The grade consideration due to butt rot is shown in Table 18 below. For example, a **high grade** sawlog (H-grade) fir log that is 8 m long and has a 45 cm top and severe butt rot (3/4 ratio):
 - a. Net factor = $(8.0 \text{ m} - 1.2\text{m})/8.0 \text{ m} = 85\%$
 - b. Grade consideration = 3.6 m (Table 18) = $(8.0 \text{ m} - 3.6 \text{ m})/8.0 \text{ m} = 55\%$
 - c. Therefore it is an I-grade since it does not meet the minimum lumber percentage criteria for an H-grade.

Measure all log lengths from the high-side ground level.

Determine the longest standard length and highest sort that the butt log can be based on the grading rules and standard log lengths.

The last grade on the tree will have a "99" recorded to the top regardless, of the utilization limits. Try not to create short logs at the top of the tree.

On short, small diameter logs record J 99 if an 8 m log with a 15 cm top can be achieved or if not then record U 99.

Cut Stems - If the tree has missing portions then the missing portion is graded as "N" and net factor "00".

3.2.2. Grading Conventions and Guidelines

Conventions

1. All dead trees or pieces, standing or fallen, must have at least one U-grade or better log that is at least 8 metres long **to be tallied. Record all logs in the tree if the first intact 8m log that starts after pencil bucking of root balls, breaks, shatter, missing wood or chainsaw cuts is a U-grade or better.**
2. The primary objective is to have logs in the appropriate end use sort. Grades within the sort are a secondary objective.
3. The grades and the grading rules are simplifications of the statutory grading rules and are not intended to match statutory grading rules and logic.
4. The standard lengths are 13, 11 and 8 metres.
5. Specified helicopter operations have additional options of 6 metres and 4 metres.
6. Shingle lengths are a minimum of 4 metres increasing in 1 metre increments up to 13 metres.
7. Pulp (Y-grade) lengths are in increments of 1 metre. Attempt to use standard lengths.
8. Grade "Z" is used for non-recoverable and shatter, and grade "N" is used for nothing there (missing wood).
9. The last log in a tree is described "99" to indicate the top of the tree.
10. Ring shake is recognized for all species except Cedar and Cypress.
 - a. Large trees that have been sheltered throughout most of their growth but have a major broken top (40 cm) as a result of wind damage, or
 - b. Large trees without broken tops which have clearly been exposed to wind over an extended period of time (i.e., vets in immature stands).
11. Butt logs with ring shake will not grade peeler or lumber.
12. Windfall trees (with roots attached) and up to 100 cm DBH will have a 1 metre "Z" grade in the butt log.
13. Windfall trees (with roots attached) and over 100 cm DBH will have a 2 metre "Z" grade in

the butt log.

14. Standard procedure-based deductions will be used to determine the extent of the defect and the calculation of the net factor (% sound wood).
15. Pencil bucking for non-standard log lengths is used for tree shape (forks, pistol butt) as well as extreme decay or missing wood.
16. If it is necessary to calculate log volumes the convention will be to use DBH for the butt log diameter and the estimated midpoint diameter for logs above the butt log.

3.2.3. Guidelines

3.2.3.1. Heart Rot:

- Conk, blind conk, and rotten branches have specific lengths and grades applied.

Conk	Y	2 m above, 4 m below, 50% sound
------	---	---------------------------------

Blind Conk	Y	4 m above, 6 m below, 50% sound
------------	---	---------------------------------

Rotten Branch	Z	1 m above, 1 m below, 50% sound
---------------	---	---------------------------------

- Severe cylindrical cat face should be pencil bucked at the top of the cat face, with that length and net factor used to determine the grade.

3.2.3.2. Butt Rot

- Butt rot is generally included with the log for its standard length with the exception of the cedar shingle sorts.
- Refer to the Butt Rot Guide for the Length Deduction table. Note that the net factor may determine the grade, based on the % lumber recovery or other grade requirements. The table also provides a guide for “grade considerations”.
- Butt rots are considered to be conical unless there is visible evidence that it is cylindrical.
- Schweinitzii - The section affected by schweinitzii and other butt rots cannot be a peeler sort.

Table 18 Butt Rot Guide for Length Deductions

Ratio	Length Deduction	Grade Consideration*
¼ diameter	0.2 m	0.6 m
½ diameter	0.4 m	1.8 m
¾ diameter	1.2 m	3.6 m
4/4 diameter	2.4 m	4.2 m
Sounding	0.8 m	2.4 m
P. schweinitzii	0.6 m	2.0 m
*Grade consideration describes how much of a log will not produce 2 by 4's at least 8 feet long.		

3.2.3.3. Frost Cracks

- Multiple frost cracks and their position around the tree may affect lumber recovery and must be considered in the determination of the sort and grade.
- Peeler sorts will not permit frost cracks.

The angle, position, or net factor will determine the appropriate grade based on % lumber recovery and/or % merchantable.

3.2.3.4. Occasional Larger Knots

All grades except peeler can have occasional larger knots (OLK's) to the extent of one per 3 meters of log length [two per 3 meters for X grade logs over 50 centimetres top diameter]. The oversize knots must be confined to the portion of the log where the allowable knots are permitted.

3.2.3.5. Weather Checks and/or Insect Damage

- A check is a separation of the wood, at right angles to the annual rings. There is no sound wood deduction for weather checks or insect damage unless there is rot associated with them.
- Logs with <10 cm sound core are Y-grade

- Logs with <10 cm sound collar are Y-grade.

Formula for Grade Consideration Calculation of Sound % Lumber

Where:

r = radius of the portion that can be sawn into lumber, and

R = radius of tree

EXAMPLE

DBH = 50 cm; Radius of tree (R) = 25 cm; Sun check = 5 cm

Radius of sawable lumber portion (r) = 20 cm

Whole tree is weather checked

$$\begin{aligned} \% \text{ Recovered} &= \frac{\pi r^2}{\pi R^2} \times 100\% \\ &= \left(\frac{20}{25}\right)^2 \times 100\% \text{ or } \left(\frac{40}{50}\right)^2 \times 100\% \\ &\text{(These give the same mathematical result.)} \\ &= 64\% \text{ lumber recovery} \end{aligned}$$

Note – If the weather check was sap rot, the net factor would be 64%.

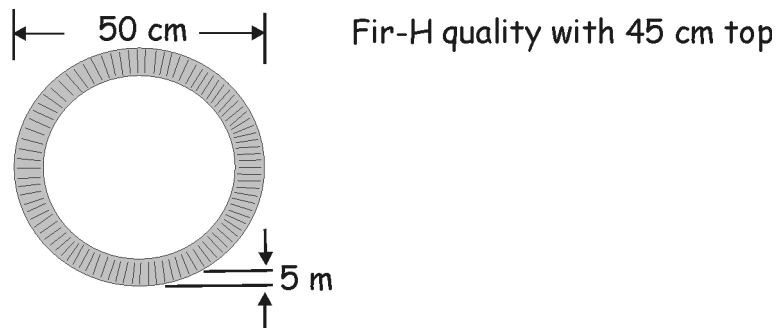

$$\begin{aligned} \% \text{ Recovery} &= \frac{r^2}{R^2} \times 100\% \\ &= \left(\frac{40}{50}\right)^2 \times 100\% \\ &= 64\% \end{aligned}$$

Figure 3-1 Example of Grade Calculation for Weather Checked Logs

3.2.3.6. Twist

- There is no sound wood deduction for twist.
- Grade considerations are applied.

- The amount of twist is estimated for 30 cm at the displacement point of the log. The percentage of twist is calculated by dividing by the estimated top diameter of the log. Twist must be less than both of these restriction as per the table below. For example, a D grade must deviate by no more than 6 cm over the 30 cm distance, and the displacement divided by the top diameter in cm must not exceed 4%.
- Twist comprises two factors: percentage of top diameter; and maximum displacement over 30 cm at the mid-point of the log. Table 19 shows the maximum values for specific grades. If the parameters are not met, the next lower grade applies.

Do not use the procedure for measuring twist that is used in Chapter 6 of the *Cruising Manual*.

Table 19 Maximum Twist Displacement by Grade

Grades		% of top diameter	Maximum displacement (over 30 cm) estimated @ midpoint
Lumber/Shingle	D, F, G, K	4%	6 cm
Peeler	B, C	7%	8 cm
Sawlog/Shingle	H, L, M	7%	8 cm
Sawlog	I	10%	9 cm
Sawlog	J	10%	4 cm
Utility	U, X	13%	13 cm

Note: Spiral grain that runs from one side of the log to the other within 2 metres is automatically Y grade.

If twist only appears on a portion of a tree and will affect the sort, then apply a shorter standard length.

EXAMPLE
<p>Calculations</p> <p>Estimated top DIB: 60 cm for log section</p> <p>Severe twist 8 cm (along 30 cm section)</p> $\% \text{ twist} = (8 \text{ cm twist}) / (60 \text{ cm top}) * 100\% = 13\%$ <p>This log is graded as U, since this is the first grade met in the hierarchy (other defects may lower the grade further).</p>

Figure 3-2 Examples of Grade Calculation for Twist

3.2.3.7. Cedar Shingle Criteria

Cedar will not be graded as a shingle if it can make a **mid grade** sawlog grade. If a log, due to heart rot, butt rot, or is not suitable for **mid grade** sawlog due to fluting, breakage, excessive butt rot, etc. but meets slab thickness requirement for that grade, the log becomes shingle grade. Lengths in 1 m increments are acceptable starting at 4 metres.

Table 20 Falldown of Lumber and Sawlog Grades to Shingles due to Defect

Initial Grade	Changes To
D grade	K grade
F grade	L grade
H/I grade	M grade

3.2.3.8. Lumber Grades

Log grade merchantability criteria will typically be written as “90% surface clear”. In application this indicates 10% of the log may have knots or knot indicators on any surface from the top of the log with the remaining 90% of the log being clear of knots. There is not a limit to the size of the knots or indicators. The lumber grades do not allow any conk or visible conk stain. Butt rot is allowed as long as the minimum lumber and merchantable requirements are met. If knot indicators are not visible, assume that knot indicators will extend 2 branch whorls below the last visible stubs or branches.

3.2.3.9. Tree Form

Sweep, major forks, pistol butt and any odd shapes which will normally be left behind during logging may be pencil bucked out and graded appropriately.

3.2.3.10. Last Log

- Mature block - last log generally a “Y” to the top, sometimes a “U” to the top. CGNF to a 15 cm top.
- Second growth block or maturity unknown - last log generally a "U" grade. CGNF to a 10 cm top.

3.2.3.11. Dead/Dry Tops

Dead and dry tree tops are often severely weather checked. If there is evidence of sap rot and the depth will reduce the core diameter to less than 10 cm, then record the log as Y-grade (pulp).

3.2.3.12. Ring Shake

Ring shake or water shake is the separation of the annual rings. If any of the following conditions are met (except cedar and cypress), then the butt log grade will not be considered suitable for the lumber or peeler sorts and a standard log length of 8 metres will be assigned:

- Large trees that have been sheltered throughout most of their growth but have a major broken top (40 cm) as a result of wind damage, or
- Large trees without broken tops which have clearly been exposed to wind over an extended period of time (i.e., vets in an immature stand).

3.3. Missing Wood and Separated Pieces

1. For all chunks and tree pieces > 8 metres length the DBH is measured 1.3 m up from the big end.
2. If it is obvious that the tree piece originated from a nearby stump, then CGNF all of the portions as one tree.
3. Project the total height of trees with broken tops and record the projected height in the tree height column of the cruise tally card. Record the grade and net factor of the missing portion as “N 99 00”.

3.4. Revenue Call Grading Criteria

CGNF CRUISING

FIR & PINE (No Pine Peelers)

DIMENSIONS	CUT (min)	KNOTS (max diameter)
D LBR ▶5.0m ▶76cm	75 %	90% surface clear
F LBR ▶5.0m ▶60cm	75 %	60-75cm, 75% surface clear ▶76cm, knots allowed 75% 1 side or 50% 2 sides
B PLR ▶5.0m ▶60cm	80 % Veneer	60-75cm, 1 clear butt block ▶76cm, knot ind butt block
C PLR ▶5.0m ▶38cm	80 % Veneer	4cm max
H S/L ▶5.0m ▶38cm or ▶50cm	75 % 50 %	▶38cm to 4cm reas well spaced, or 5cm on top 1/2 * , ▶50cm, 5cm on top 2/3 * , or 8cm on top 1/2 * * 2cm on bottom portions
I S/L ▶5.0m ▶38cm or ▶50cm O/W H Quality	75 % 50 % 50 %	▶38cm, to 8cm ▶50cm, to 9cm ▶76cm, to 10cm
J S/L ▶5.0m 15 – 36cm	75 %	15-26cm, to 4cm 29-36cm, to 6cm
U UTL ▶5.0m 10-14cm or ▶5.0m 15-36cm or ▶5.0m ▶38cm	75 % 66.7 % 50 %	10-14cm to 4cm; 15-26cm to 6cm 27-36cm to 8cm; 38-48cm to 10cm 50-74cm to 12cm; ▶76cm to 14cm
X UTL ▶5.0m ▶10cm	33.3 %	same as U, except ▶50cm allow 2 OLJK / 3m
Y CHPR ▶3.0m, poorer than X UTL, better than Z NON RECOVERABLE		
Z for appraisal – Z is NON RECOVERABLE (NRac)		

HEMLOCK & BALSAM

D LBR ▶5.0m ▶66cm	75 %	66-74cm 90% surface clear ▶76cm 80% surface clear
F LBR ▶5.0m ▶60cm	75 %	50-64cm 75% surface clear ▶66cm knots allowed 75% 1 side or 50% 2 sides
H S/L ▶5.0m ▶38cm O/W D or F Quality	75 % 50 %	see Fir H knot specs
I S/L ▶5.0m ▶38cm O/W H Quality	75 % 50 %	see Fir I knot specs
J S/L, U UTL, X UTL, Y CHPR, Z NRac see FIR specs		

CYPRESS

D LBR ▶5.0m ▶60cm	75 %	66-74cm 75% surface clear ▶76cm 67% surface clear
F LBR ▶5.0m ▶50cm O/W D Quality	75 %	50-58cm 75% surface clear ▶60cm - knots allowed 75% on 1 side or 50% 2 sides
H S/L ▶5.0m ▶38cm	50 %	see Fir H knot specs
I S/L ▶5.0m ▶38cm	50 %	see Fir I knot specs
J S/L ▶5.0m 15-36cm	75 %	see Fir J knot specs
U UTL, X UTL, Y CHPR, Z NRac see FIR specs		

SPRUCE

F LBR ▶5.0m ▶76cm	75 %	90% surface clear
G LBR ▶5.0m ▶60cm	75 %	60-74cm, 75% surface clear ▶76cm, knots allowed 75% 1 side or 50% 2 sides or 75% shopgrade ▶100cm, 50% shopgrade
H S/L ▶5.0m ▶38cm	75 %	see Fir H knot specs
I S/L ▶5.0m ▶38cm or ▶50cm	75 % 50 %	see Fir I knot specs ▶100cm to 13cm max
J S/L ▶5.0m 16-36cm	75 %	see Fir J knot specs
U & X UTL, same as Fir except logs ▶100cm allow knots to 16cm		
Y CHPR, Z NRac see Fir specs		

SPIRAL GRAIN - % of top diameter				OCC LGR KNTS
4%	7%	10%	13%	
D, E, F, G, K	B, C, H, L, M	I, J Ungrd Spec	U, X	1 per 3m length;
6cm max	8cm max	I=9cm, J=4cm	13cm max	X-UTL ▶50cm up to 2 per 3m

HARDWOODS : DECIDUOUS SPECIES

C (cottonwood only) ▶5.0m ▶25cm Max twist 7% (8cm)	80 % Veneer	Knots < 4cm well spaced NO Conk, NO Butt Rot NO Sweep, No Crook
I S/L ▶5.0m ▶25cm	50%	25-36cm to 4cm; 38-48cm to 8cm; ▶50cm to 9cm
U UTL ▶5.0m 10-14cm or 15-24cm or ▶25cm	75 % 66.7 % 50 %	10-14cm to 4cm; 15-26cm to 6cm 28-36cm to 8cm; 38-48cm to 10cm ▶50cm to 12cm;
Y CHPR poorer than S/L, better than NRac, Dead Potential = Y or lower		
Z NRac, see Fir specs		

CEDAR (NO POWDER WORM in D, F, K, L, M, H - n/a CGNF)

DIMENSIONS	CUT	KNOTS (diameter)
D LBR ▶5.0m ▶60cm or ▶120cm	75 % 66.7 %	60-74cm 75% surface clear ▶76cm 67% surface clear
F LBR ▶5.0m ▶50cm	75 %	50-54cm surface clear; 60-74cm 67% surface clear ▶76cm knots allowed 75% 1 side or 50% 2 sides
K SHG ▶4.0m ▶50cm Slab ▶38cm thick	50 SS	50-58cm surface clear ▶60cm same as Cedar D
L SHG ▶4.0m ▶38cm Slab ▶26cm thick	50 SS	50% surf. Cir. Or spacing, round logs >60cm allow spacing
M SHG ▶4.0m ▶38cm Slab ▶16cm thick	50 SS	25% surf clear, or spacing, round logs >50cm allow spacing
H S/L ▶5.0m ▶38cm	75 %	see Fir H knot specs
I S/L ▶5.0m ▶38cm or ▶10.0m ▶50cm O/W H Quality	75 % 50 % 50 %	see Fir I knot specs see Fir H knots
J S/L, U & X UTL, Y CHPR, Z NRac see Fir specs		

SLABS

	D,F,K	H,I	L	M	U	X
Thickness	38cm	38	26	16	16	10
Mean dia.	50cm	38	38	26	16	10

Cedar : Use knot specs based on slab width. Thickness is rgt. angle to grain
Other species, I S/L & better, 38cm thick & mean diameter ▶ grade rule

GENERAL FACTORS & RULES

LOG LENGTHS: Standard lengths 8m, 11m, 13m Min lgths 5m, Shingle 4m, Y 3m Hell Blocks, 4m & 6m allowed	LUMBER – no conk or blind conk DEAD – must > 8m Gr U No Top = Gr N 99 00%
CROOK & PISTOL GRIP IN PEELERS <8.0 m - no loss allowed 8.0 m to <11.0 m - up to 1.2m Grade Con. ▶11.0 m - up to 2.0m Grade Con.	BUTT ROT IN PEELERS <8.0 m - none allowed 8.0 to <11.0 m - 1/3 butt meas ▶11.0 m - 1/2 butt meas
SWEEP in PEELERS <8.0 m - up to 0.6m Grade Con 8.0 m to <11.0 m - up to 1.2m Grade Con. ▶11.0 m - up to 2.0m Grade Con Mental Bucking Allowance <8.0 m - NO Bucks Allowed 8.0 m to <13.0 m - 1 Buck only ▶13.0 m - 2 bucks only	CONK +2m /-4m NF 50% Gr Y B/CONK +4m/-6m NF 50% Gr Y Fork w/decay 1m NF 50% Gr Z Crk w/decay 1m NF 50% Gr Z Rot Brch +/- 1m NF 50% Gr Z Shatter/Breakage – Gr Z Root Rot Deduct 0.6m

BUTT ROT GUIDE		
B/Rot Diam Ratio	N/F Deduction	Grade Consideration Length Not Recoverable
1/4	0.2m	0.6m
1/2	0.4m+	1.8m
3/4	1.2m+	3.6m
4/4	2.4m	4.2m
Sounding	0.8m	2.4m
P. schweinitzii	0.6m	2.0m

▶ means equal to or greater than (= or >)

O/W = otherwise

NB: Common lower grades are listed under FIR & PINE

4. Quality Assurance

This document outlines the CGNF quality assurance (QA) standards and procedures.

The standards and procedures are:

1. Primary standards – Net Volume and Value.
2. Appraisal standards – timber cruising attributes that do not necessarily affect the volume or value, but affect the appraisal.
3. Plot selection.
4. Quality assurance reporting – the sequence for the reporting levels.

4.1. Primary Standards

- a. Mature Net Volume Standard – the original cruise must be within +/- **10%** of the check cruise net volume per hectare.
- b. Second Growth Net Volume Standard – the original cruise must be within +/- **10%** of the check cruise net volume per hectare.
- c. Mature Value Standard – the original cruise must be within +/- **15%** of the check cruise value per m³.
- d. Second Growth Value Standard – the original cruise must be within +/- **15%** of the check cruise value per m³.

The net volume and value calculations will be based on the compilation of the original plots in 1.0 hectare and the check plots in 1.0 hectare.

4.2. Appraisal Standards

The appraisal requirements are:

- a. Damage coding – consistent with the standards in Chapter 3 of the *Cruising Manual*.
- b. Plot slope - consistent with the standards in Chapter 3 of the *Cruising Manual*.
- c. Plot Locations - consistent with the standards in Chapter 3 of the *Cruising Manual*.
- d. Sounding.

The check cruiser will use an increment borer when they need to confirm the presence of butt rot determined by sounding. The check cruiser will always apply the 0.8 m length deduction when the boring confirms the presence of rot regardless of the thickness of the sound wood collar.

4.3. Plot Selection

Refer to Section 3.6 of the *Cruising Manual* for the details regarding the risk assessment and sampling intensity for check cruising.

In addition, the following minimum standards will apply:

A minimum of 5 full measure plots must be audited in order to reject a cruise (or other types of plots containing at least 20 volume measure trees), unless agreed to by the licensee or consultant.

4.4. Preparing the Quality Assurance Summary

1. Complete a summary report for each check plot and for all the plots checked.
2. Compile the audit sample to determine whether the net volume and value meet the standards. If the net volume and value standards are not achieved, then the cruise will be rejected and the reasons for the excessive variations documented and signed by the check cruiser.
3. Note that the net factor for a Z-grade piece is called as per the original cruisers estimate and is not subject to audit.
4. The check cruise report will be sent to the cruiser and licensee.

Selling Price Comparisons

The value standard is based on the average of the Vancouver Log Market selling prices published by Timber Pricing Branch. The average selling prices by maturity and sorts will be used for calculating the selling prices for check cruising purposes and they will be updated periodically to reflect relative prices between sorts. The prices are posted on the Timber Pricing Branch website at the following location:

https://www2.gov.bc.ca/assets/gov/farming-natural-resources-and-industry/forestry/timber-pricing/timber-cruising/weighted_selling_price_2019.pdf

If the “Net Immature by Block %” is 50.0% or less for the cutblock being check cruised, the “Weighted Coast Selling Prices – Mature” are to be used. Otherwise the “Weighted Coast Selling Prices - Second Growth” are to be used. This determination is made by compiling the original cruiser’s CGNF data as submitted prior to a check cruise. Alternatively, the cruiser and check cruiser may mutually agree to use one of the selling price tables provided at the location above.

4.5. Acknowledgements

The following groups and individuals have provided extensive guidance in the production of this manual:

- Alec Orr-Ewing, A. Orr-Ewing & Associates
- Bert Vink, Cascadia Forest Products Ltd.
- British Columbia Institute of Technology
- Bruce Markstrom, Coast Forest Region, Ministry of Forests and Range
- Canadian Forest Products Ltd.
- Coastal Loss Factor Committee
- Dennis Swennson
- Dr. Kim Iles, Kim Iles & Associates
- International Forest Products
- Jeff Kerley, Kerley & Associates Forestry Consulting Ltd.
- Jim Wilson, JS Thrower & Associates Ltd.
- Mike Fall, Brenton Forest Surveys
- Norm Shaw, BCIT
- Resource Information Standards Committee
- Revenue Branch, Ministry of Forests and Range
- Ron Mecredy, Mecredy Cruising and Forest Consulting
- TimberWest Forest Limited.
- Vegetation Resources Working Group
- Verne Sundstrom, Forestry Consultant
- Will Smith, Forest Analysis and Inventory Branch, Ministry of Forests and Range
- Western Forest Products Inc.
- Weyerhaeuser Company Limited

5. Appendices

5.1. Appendix 1: Damage Codes

5.1.1. Insect

The types of defects normally associated with insect damage are sap rot and weather check. Use the sap rot net factor calculation for insect damage. The weather checks affect the quality of the log and are a factor in grade consideration and not volume. Record the insect damage codes as per Appendix 6.1 of the *Cruising Manual*

5.1.2. Fire

The types of defects normally associated with fire damage are saddle burns and weather checking due to rapid drying by the fire. Saddle burns are net factored the same way as scars and the weather checks are a factor in the grade consideration. Excessive saddle burning may result in 1 or 2 metre segments of Z-grade. Record the fire damage codes as Light (L), Moderate (M) and Heavy (H) as per Appendix 6.2 of the *Cruising Manual*.

5.1.3. Down Tree

Fallen trees that have their roots attached will have a 1 metre Z grade for the first log if they are < 100 cm at DBH and a 2 metre Z grade if they are > or = 100 cm. Shatter in the tree will be a pencil bucking point. Record the down tree damage code as (E) or (G) and standing trees as (blank). Note that either code E or G can be entered for fallen trees for CGNF cruises since there is not a risk group dependency.

Coast Cruise Tally Card Details (FS 205) - note that bold positions are required for CGNF cruises.

Card Type 9

*Positions 2 to 7	Licence number (alpha/numeric).
*Positions 8 to 10	Cutting permit number (alpha/numeric).
*Positions 11 to 13	Cutblock number (alpha/numeric).
Positions 14 to 15	Cruise strip number (alpha/numeric).
Positions 16 to 17	Cruise plot number (alpha/numeric).
Position 18	Original (O or blank) or Check (C) cruise.
Positions 19 to 20	Timber type number (alpha).
Positions 21 to 24	Age in 10s and Height – required for loss factor cruises only.
Position 25	Measure (M) or Count (C) plot (alpha).
Position 26	Vacant
Position 27 to 30	Main Plot Size (numeric) = fixed area plot size in hectares.
Positions 31 to 35	Main Plot Size (numeric) = prism size = Basal Area Factor in M/CM.
Position 36	Full (F) measure or Walkthrough plot (alpha).
Positions 37 to 39	DBH Limit (numeric) – 12.0 for second growth cutblocks and 17.5 cm for mature cutblocks.
*Positions 53 to 54	Harvesting Method (alpha) – see Chapter 6 of the <u>Cruising Manual</u> for the acceptable harvesting method codes.
Positions 55 to 57	Slope percent (numeric) – the maximum slope within 15 metres slope distance and within the harvest area.
Positions 58 to 59	Year (numeric).
Positions 60 to 61	Month (numeric).

* Data positions marked with an asterisk will not be a check cruise item during check cruises in the field since they may not be known until later.

Card Type 2

Positions 25 to 26	Tree number (numeric).
Positions 27 to 29	Tree height (numeric).
Positions 30 to 31	Species – (alpha) – see Chapter 6 of the <u><i>Cruising Manual</i></u> for the acceptable genus and species codes.
Positions 32 to 35	Diameter at breast height (numeric).
Position 36	Tree Class – loss factor cruises only (numeric).
Positions 37 to 44	Pathological Indicators – loss factor cruises only (numeric).
Positions 45, 48, 49, 50, 51	Quality Remarks – loss factor cruises only – (alpha/numeric).
Position 59	Selective Cutting Indicator – mark to cut (C or blank) or leave (L).
Position 60	Root rot codes J, K, L.
Position 61	Insect/defoliator codes – (alpha/numeric).
Position 62	Fire damage codes A (light), B (moderate), C (Heavy).
Position 63	Down tree codes E or G or standing (blank).
Position 64	Mature (M) or Second growth (S) – second growth conifer is less than 141 years old and deciduous is less than 41 years old.
Position 65	Live (L) or Dead (D) – dead trees do not have any live cambium.
Positions 66, 71, 76, 81, 86	Log grades #1 to #5 – (alpha) – note that if a tree has more than 5 logs then the next row can be used for logs #6 to 10.
Positions 67-68, 72-73, 77-78, 82-83, 87-88	Log lengths #1 to #5 – (numeric) – nearest whole metre – note that if a tree has more than 5 logs then the next row can be used for logs #6 to 10.
Positions 69-70, 74-75, 79-80,84-85,89-90	Log net factors #1 to #5 – (numeric, percent soundwood to nearest whole number in percent) – note that if a tree has more than 5 logs then the next row can be used for logs #6 to 10.

Card Type 3

Positions 25 to 26	Tree number (numeric).
Positions 27 to 29	Tree height (numeric).
Positions 30 to 31	Species (alpha).
Positions 32 to 35	Diameter at breast height (numeric).
Position 36	Crown class codes 1 to 4 (numeric).
Positions 37 to 39	Total age in years (numeric) – note that this age includes corrections.
Position 40	Selective cutting indicator - mark to cut (C or blank) or leave (L).
Positions 41 to 43	Counted age in years (numeric).
Positions 44 to 45	Corrected years (numeric) – note that this value is derived from the Site Index Tables for B.C. in Appendix 9 of the <u><i>Cruising Manual</i></u> .
Positions 46 to 47	Bored height in metres (numeric) – this is DBH (1.3 metres).
Additional Fields	Borderline tree measurements and tree remarks can be entered.

Back of Cruise Tally Card

The cruiser and check cruiser are required to print and sign their name and date each tally card.

5.3. Appendix 3: Transition from Loss Factor to CGNF Cruising

CGNF cruising commences January 1, 2007. Loss factor cruising will be required concurrently with CGNF cruising for at least one year.

The following standards are required until dual data collection is no longer required:

Dead useless, live useless and dead potential tree classes will be recorded as follows:

1. Dead Potential Tree Classes with a least an 8 m U-grade – CGNF all of the logs in the tree.
2. Dead Potential Tree Classes that do not have at least an 8 m U-grade – record the CGNF attributes as Z-99-00.
3. Dead Useless Tree Classes with at least an 8 m U-grade – CGNF all of the logs in the tree. Record the DBH and the total projected tree height.
4. Dead Useless Tree Classes that do not have at least an 8 m U-grade – do not record or measure these trees.
5. Live Useless Tree Classes – CGNF the whole tree as per the standards. Record the DBH and the total projected tree height.
6. Use the Map Area Statement Card Type D block maturity indicator for the loss factor and the CGNF cruises in the transition period from loss factor to CGNF cruising.

Appraisal and Timber Merchantability Standards

Down Tree Codes – Position 63 on the tally card – continue to code E or G as per Section 6.3 of the *Cruising Manual*. Only one code will be necessary once loss factor cruising is not required.

Live/Dead – Position 64 on the tally card – code L for live trees and D for dead trees since the CGNF cruise compilation program requires this information for the assignment of the net volume adjustment factors.

Mature/Second Growth – code “M” for mature coniferous trees greater than 140 years old and mature deciduous trees greater than 40 years old. Code “S” for coniferous trees less than 141 years old and deciduous trees less than 41 years old. The percent immature by block and the percent second growth for the cutting authority will continue to be calculated using the age in 10s and tree class while these attributes will be calculated using codes “M” and “S” for CGNF cruising.

Note – dead useless trees that do not have at least an 8 m U-grade log in them are no longer recorded in CGNF and loss factor cruises.