

## WOOD FENCE CONSTRUCTION

This factsheet discusses construction of Post and Rail, Snake Rail, Log and Block, and Russell Fences, along with right-of-way preparation information.

### RIGHT-OF-WAY PREPARATION

During the initial planning stage, the fence purpose, type of animal and site conditions are used in choosing a fence design. These points must also be kept in mind when preparing the right-of-way and laying out the fence.

There are two basic types of fence right-of-ways:

- boundary fence right-of-way
  - these fences have predetermined locations
  - right-of-way work may be restricted to the builders side of the right-of-way
- general farm fence right-of-way
  - right-of-way location is less restricted
  - right-of-way can be chosen to suit the builder

Preparation will vary greatly: forested sites will require logging; bushed sites may be mowed; grasslands may need little preparation. A well prepared right-of-way with good access assures a work area that can help the fence builder and result in a good fence. Good right-of-ways are also important for fence maintenance, etc.

Decisions made in preparing the right-of-way have effects through construction, use and maintenance of the fence. Some points to consider:

**Plan.** Know the area well before finalizing the right-of-way.

**Access.** Prepare the right-of-way so a fence line can be laid out with good access to both sides (i.e., for a cattle range fence, ensure a horse & rider will be able to move along both sides of the fence after it is constructed).

**Straightness.** Keep the right-of-way as straight as possible to simplify wire fence construction; all-wood fences have less need for a straight right-of-way.

**Direction Changes.** Right-of-way changes of direction should be done keeping in mind the ideal tensioning distances of wire; 660 feet (barbed and woven) and 1,320 feet (htsw). Because tie-off braces will be located at these approximate distances, change of direction at these locations will not add greatly to fence costs.

**Uneven Terrain.** Remove minor undulations where possible but consider seasonal water flows when filling dips or gullies. Culverts or flood gates may be required.

**Windfalls.** Remove dead, defective or leaning trees that could fall across the fence.

**Slash.** Pile and burn all slash and waste wood (or cut and leave to rot) to ensure the right-of-way is passable.

**Visibility.** Some right-of-ways may have to be prepared using low impact methods if visibility is a concern.

## Right-of-Way Vegetation

Although this is done after fence construction, it is important to remember that all disturbed soil from right-of-way preparation should be seeded to grasses to discourage weed growth.

## FENCE LINE LAYOUT

Once the right-of-way has been prepared, the actual fence line location can be established. There are two typical situations depending on who the builder is:

- owner built – as you know what you want, flag the fence line as required
- contractor built – be certain he knows your instructions **and** you flag well to identify everything required

Fence line layout along the right-of-way is commonly done using plastic flagging tape. Choose a bright, easy to see colour, and:

- using single flags (or sight stakes if needed), place often enough so you can stand at one and see the next - at dips or rises, extra flags or sight stakes will be required to ensure a straight fence line as shown in Figure 1, below
- using double flags, mark all changes of direction, gates, or other instructions - use a felt pen to write on the flag what is required (such as corner brace, etc)

Note that tie-off points may be up to the distances as recommended for the type of fence wire. At this point, a detailed materials list can be assembled, materials ordered, delivered to the site and construction can start.

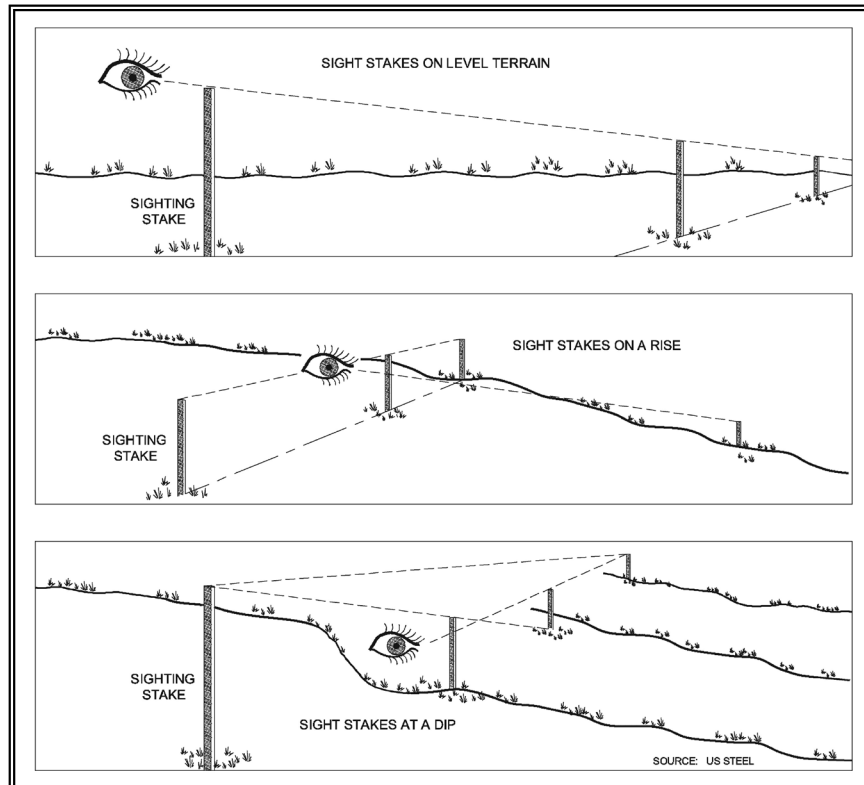

**Figure 1** Fence Line Layout Using Sight Stakes

## CONSTRUCTION OF ALL WOOD FENCES

These type of fences range from the easiest to build (Post and Rail) to among the most difficult to build (Russell Fence).

### A Note About Nails

Spiral shank nails have up to twice the holding power of the same sized smooth shank nails. Sold under the Ardox name, these nails are often chosen for fencing applications such as joining wooden rails to posts. Ardox nails have a smaller diameter shank than the same size smooth shank nail, are made of a higher grade steel and their per-nail-cost can be lower.

### Post and Rail Fence Construction

See post and rail design information on page 5 of Factsheet 307.260-1, *Livestock Control, Non-Electric Fence Designs*.

- Post spacing is governed by the rail length available; allowing approximately 6 inches of rail length at each post for 'overlap', the post spacing is then 1 foot less than the rail length.
- Rails may be staggered (over/under) or slanted from post to post as suits the builders 'eye'. Rails are applied to the animal side of the posts. Otherwise, vertical boards are attached at each post over the rails and wired to the post to ensure the security of the fence.
- Alternatively, rails can be butt joined at the posts if the rails are twice the length of the post spacing; stagger the joints so they are not all on the same post.
- Board rails may be nailed directly to posts; round rails should be notched with an axe. Cut a curved 'scoop' type of notch in the round rail to mate with the curved surface of the post to ensure a proper rail-to-post connection.
- For most livestock, use rough cut, unplanned boards for rails; if round rails are used, peel the bark off on a minimum three sides.
- Use spiral shank (Ardox type) nails for superior holding strength; one nail per round rail-to-post connection or two per board-to-post connection.
- Flat steel washers used with nails will increase the nail head area for greater holding strength.

### Snake Rail Fence Construction 3-Log

See Figure 2 below and design information on page 6 of Factsheet 307.260-1 *Livestock Control, Non-Electric Fence Designs*.

The following is the "even stacked" method where each log has both ends on top of the previous log (not shown here, the "uneven stacked" method is where each log has one end on top of the last log and the other end under the next log).

- Ensure sufficient right-of-way width to accommodate this 'wide' fence style.
- Note that all rail notches are on the underside of the rail to prevent water from accumulating and causing wood rot.
- Follow the procedure below as shown in Figure 2.
- String a guide wire or string approximately one foot to the fence side of the 'end-of-log' sight line.

- Use peeled wooden starter blocks (pressure treated preferred; or flat rocks where available) set out the panel length for the first panel. The first block will be set at the guide wire and the other set to the fence side to establish the 'snake' (the second block will be the panel length from the first and the panel width from the guide wire). See Figure 2 (A)
- Notch the first regular panel, bottom rail, to fit the blocks and set in place.
- The starter panel is then laid out. It is different from the first regular fence panel as it must be self supporting. To do this, a triangular panel is constructed as the first few regular panels go up. After this starter panel is complete, the fence progresses normally.
- Set the starter panel block about 6 or 7 feet away from the first panel block and about the same distance from the first panel, bottom log. Notch and set the first row starter log (about one-half a regular log length) on this starter block and back onto the midpoint of the bottom first panel rail (make a small notch so it will sit on this rail). See Figure 2 (B)
- Notch and lay the second starter log on top of the first starter log/block and over to the bottom first panel log, forming the first starter triangle.
- Before the first panel, second row log can be set, the second to fifth panels must be started i.e., the first, third and fifth panels will each have the two starter blocks set and each will have the bottom log notched and set in place). See Figure 2 (C)
- The first row log can now be set in the second and fourth panels (notched and set on top of the bottom logs of the adjacent panels). See Figure 2 (D)
- The second row log in the first and third panels is notched and set. See Figure 2 (E)
- The two second row end starter logs are notched and set in place.
- The second row log in the second panel is notched and set in place.
- The third row (last log) in the first panel is notched and set in place.
- With the triangular starter panel two logs high and the first regular panel three logs high the fence is underway. Each panel can now be completed as sufficient panels are started in advance.
- The fence is ended similarly as it was started; a triangular end panel is constructed.
- Wire tie the top log at each end to the log beneath for security.

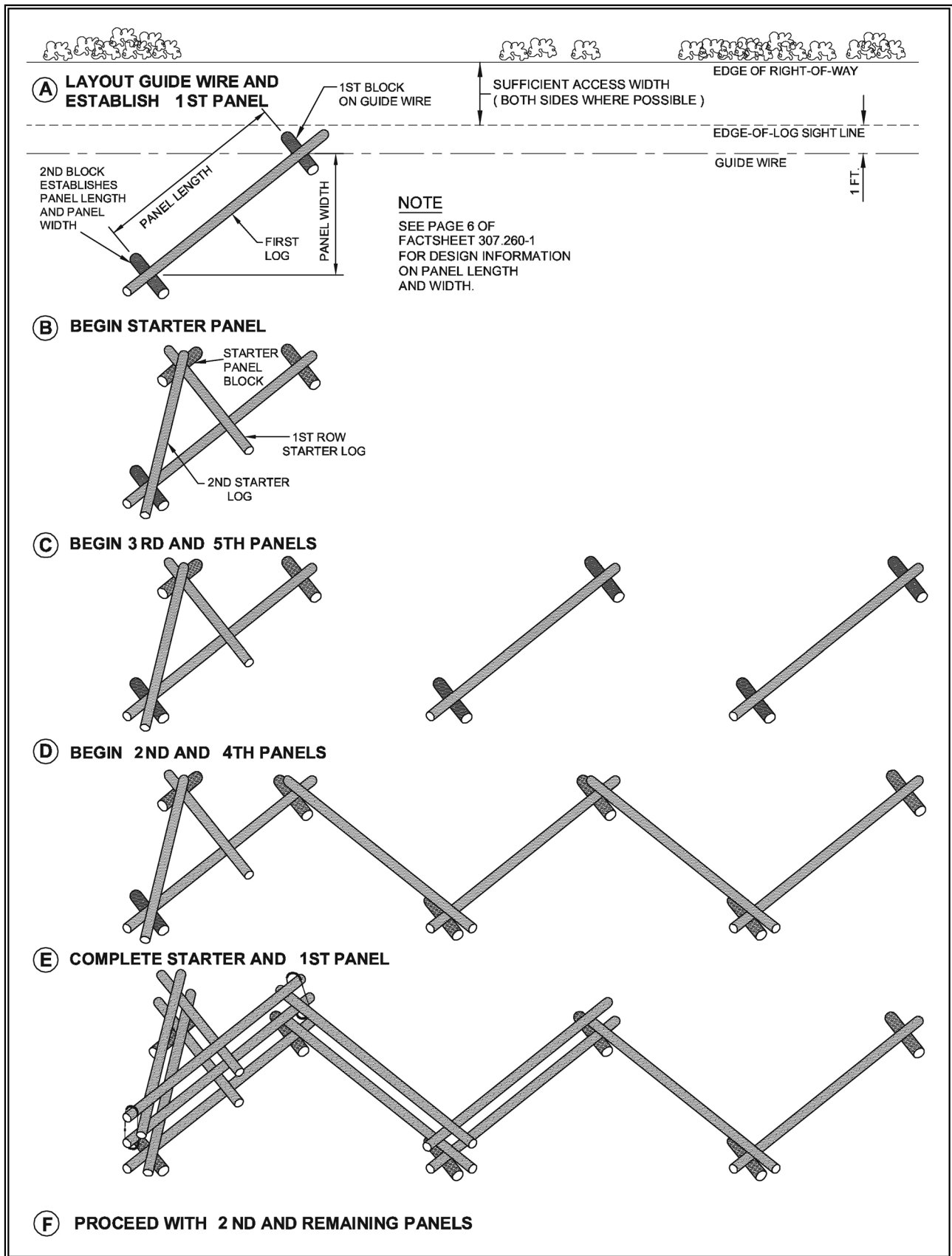

Figure 2

3-Log Snake Rail Fence Construction

## Log and Block Fence Construction

See log and block design information on page 7 of Factsheet 307.260-1 *Livestock Control, Non-Electric Fence Designs*.

- This fence is essentially a modified snake rail fence but constructed in the same manner.



## Russell Fence Construction

See Figure 3 below and design information on page 8 of Factsheet 307.260-1 *Livestock Control, Non-Electric Fence Designs*.

- These fences are constructed with four to five rails, two to four inches in diameter
- The top rail is supported in the cross of the stake poles. See Figure 3 (A)
- The second rail sets in the second wire loop. See Figure 3 (B)
- The third and fourth rails hang in the third wire loop. See Figure 3 (C)
- The key to this fence is the two tie poles which are inserted into the first wire loop and rotated so as to tighten the assembly. See Figure 3 (D)
- The tie poles meet the adjacent tie poles at mid-panel and are wire tied to the bottom rail only.
- Experience is required to judge the wire loop sizes, the twisting of the third wire loop, etc.



**(A) SLIDE STAKE POLES ONTO PREVIOUS PANEL**

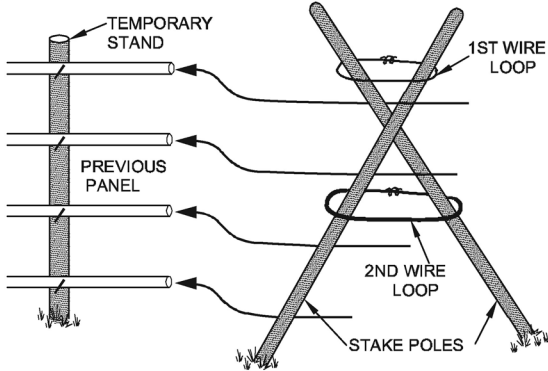

1. 10-12 GAUGE WIRE LOOPS AROUND CROSSED STAKE POLES.
2. SLIDE STAKE POLES ONTO PREVIOUS PANEL AS SHOWN.
3. TOP RAIL SUPPORTED AT CROSS.
4. 2ND RAIL SUPPORTED BY 2ND WIRE LOOP.

**(B) SET TOP, 2ND AND BOTTOM RAILS**

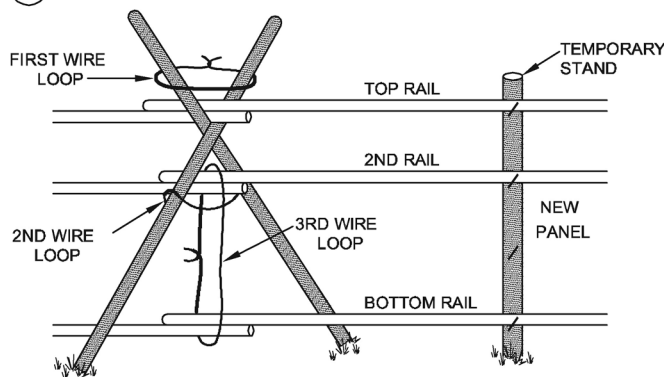

5. SET 3RD WIRE LOOP AND PLACE BOTTOM RAIL OF PREVIOUS PANEL.
6. PLACE 3RD RAIL TEMPORARILY ON THE GROUND.
7. MOVE STAND AND SET TOP, 2ND AND BOTTOM RAILS OF NEW PANEL.

**(C) TWIST 3RD WIRE LOOP AND SET 3RD RAILS**

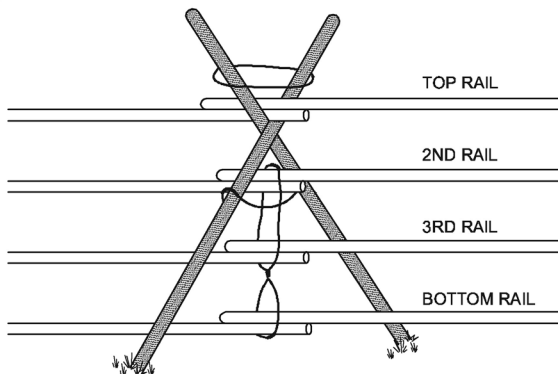

8. 3RD WIRE LOOP MUST BE TWISTED TO SET THE 3RD. RAILS.
9. TWIST AT THE DESIRED HEIGHT OF THE 3RD RAILS WITH 4 TO 5 TURNS.
10. SET 3RD RAILS IN PLACE.

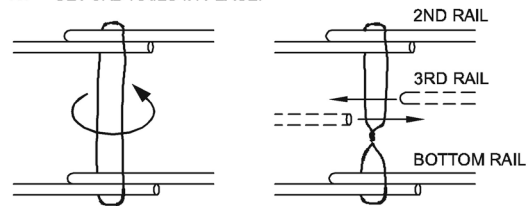

**(D) TWIST TIE POLES IN PLACE**

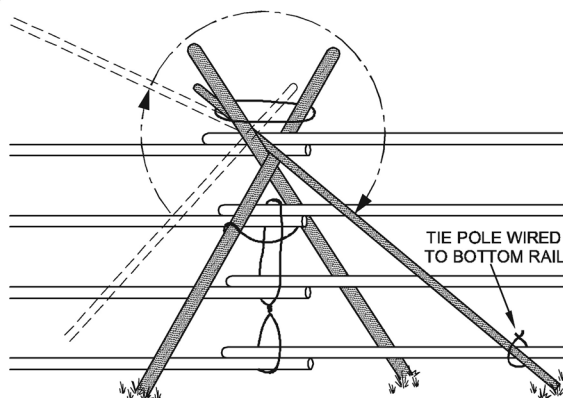

11. INSERT A TIE POLE INTO THE 1ST WIRE LOOP AND ROTATE AS SHOWN TO TIGHTEN THE ASSEMBLY.
12. TIE POLE SHOULD REACH MID PANEL WHERE IT IS WIRED TO THE BOTTOM RAIL ONLY.
13. LASTLY, THE SECOND TIE POLE (NOT SHOWN) IS ALSO INSERTED AND TWISTED IN THE OPPOSITE DIRECTION TO THE OTHER SIDE AND WIRED TO THE BOTTOM RAIL.

**NOTE**

RUSSELL FENCE CONSTRUCTION REQUIRES EXPERIENCE TO PROPERLY SET WIRE LOOP SIZE AND TO SET THE TIE POLES.

SOURCE: C. ARMES  
B.C. FOREST SERVICE

Figure 3

Russell Fence Construction

---

**FOR FURTHER INFORMATION CONTACT**

Phone: 604.556.3001  
Toll Free: 1.888.221.7141

**MINISTRY OF AGRICULTURE**

1767 Angus Campbell Road  
Abbotsford, B.C. V3G 2M3