

PART E
WATER AND WASTEWATER SAMPLING

©Her Majesty the Queen in
Right of the Province of British Columbia
2013
All Rights Reserved

AMBIENT FRESHWATER AND EFFLUENT SAMPLING

©Her Majesty the Queen in
Right of the Province of British Columbia

2013

All Rights Reserved

Table of Contents

1. INTRODUCTION.....	219
2. GENERAL CONSIDERATIONS	220
2.1 Preparing to Go to the Field.....	220
2.2 Locating the Site in the Field	220
2.3 Field Notes/Observations.....	221
3. QUALITY ASSURANCE/QUALITY CONTROL (QA/QC)	222
3.1 Field Quality Assurance.....	222
3.2 Quality Control.....	224
3.2.1 Blanks	224
3.2.1.1 Trip Blanks	225
3.2.1.2 Field Blanks.....	225
3.2.1.3 Equipment Blanks (prepared prior to the field trip)	226
3.2.1.4 Filtration Blanks.....	226
3.2.2 Replicate Samples	227
3.2.2.1 Co-located Samples (field duplicate, triplicate, etc.)	227
3.2.2.2 Split Samples	227
3.2.3 Spiked Samples (Field)	228
3.2.4 Reference Samples.....	228
4. COLLECTING SAMPLES	229
4.1 Lake	229
4.1.1 Shore Sample	230
4.1.2 Sampling from a Boat.....	231
4.1.2.1 Site Identification	231
4.1.2.2 Surface Water	231
4.1.2.3 Deep Water	232
4.1.3 Winter Sampling.....	234
4.2 River/Stream	235
4.2.1 Access from the Stream Bank	235
4.2.2 Access from a Bridge	237
4.2.3 Sampling from a Boat.....	239
4.2.4 Winter Sampling.....	239

5.	COLLECTING EFFLUENT AND RECEIVING WATER SAMPLES	243
5.1	Effluent Stream	244
5.2	Receiving Waters.....	245
6.	FIELD MEASUREMENTS	246
6.1	Temperature.....	246
6.2	Dissolved Oxygen (DO).....	247
6.3	Conductivity/Salinity	250
6.4	pH	251
6.5	Clarity	252
6.6	ORP	253
6.7	Stream Flow	253
7.	FIELD FILTRATION AND PRESERVATION.....	255
7.1	Filtration.....	255
7.2	Preservation.....	257
8.	SHIPPING.....	258
9.	CLEANING EQUIPMENT	259
10.	SOURCES OF FURTHER INFORMATION	260
11.	REVISION HISTORY	261
	APPENDIX 1 GENERIC FIELD CHECKLIST	262
	APPENDIX 2 SITE IDENTIFICATION	264
	Appendix 2.1 Site Identification Guide.....	265
	Appendix 2.2 Site Data Sheet (Lake)	266
	Appendix 2.3 Site Data Sheet (River)	267
	Appendix 2.4 Site Data Sheet (Effluent).....	268
	APPENDIX 3 SAMPLING FOR THE MOST COMMON VARIABLES.....	269
	Appendix 3.1 General Chemistry (including nutrients).....	270
	Appendix 3.2 Metals	271
	Appendix 3.3 Carbon.....	272
	Appendix 3.4 Chlorophyll a.....	273
	APPENDIX 4 SAMPLE CONTAINER, PRESERVATION, AND HOLD TIMES FOR WATER AND EFFLUENT SAMPLES.....	275
	APPENDIX 5 EFFLUENT SAMPLING CHECKLIST GUIDE.....	281
	Appendix 5.1 Effluent Sampling Checklist	282

1. Introduction

This section covers the minimum requirements to ensure quality and consistency of the field aspects of ambient water and effluent data collection. The essential tasks in water sampling are to obtain a sample that meets the requirements of the program, in terms of location and frequency, and to prevent deterioration and contamination of the sample before analysis. The procedures outlined in this section are oriented primarily towards BC Environment employees, consultants, or those under a legal requirement to undertake a sampling program for the Ministry. The protocols outlined in this section will aid field staff in collecting reliable, representative water samples.

The protocols presented here are the most acceptable ones used at present. It should be emphasized that in unusual circumstances, or with development of new methods, experienced professional judgment is a necessary component of method choice and application. It is intended that this document will be updated as the need arises to reflect new knowledge.

This section does not address the collection of samples for the purpose of providing legal evidence. For information regarding legal sampling, refer to *Guidelines for the Collection and Analyses of Water and Wastewater Samples for Legal Evidence* (Lynch and van Aggelen, 1994).

This section also does not address project design (site locations, frequency of sampling, duration, quality assurance program, etc.) or data interpretation. It also does not address the collection of groundwater samples. The protocols for the collection of ambient groundwater are documented in the Groundwater Sampling chapter of this manual.

The sample containers, preservatives and sampling procedures described in this section reflect those most widely used by BC Environment. Shipping procedures and safety measures are also outlined. Different agencies or laboratories may have specifications which differ from those described here.

It should be acknowledged that funding for the initial manuscript upon which this section is based was provided by the Aquatic Inventory Task Group of the Resource Inventory Committee.

2. General Considerations

2.1 Preparing to Go to the Field

Preparation for each sampling trip is critical since oversights are not usually noticed until staffs reach the first station. The most effective way to prepare for a sampling trip is with a **checklist** that is designed to meet the requirements of each project.

Other than considering site-specific instructions, the checklist should identify the following:

- Type and number of (labeled) bottles, including extras
- Field equipment such as meters (with adequate trouble-shooting equipment for small repairs), sampling tools (multiple samplers, through ice samplers, Van Dorns, automatic composite samplers) and filtration apparatus
- Preservatives
- Appropriate quantity of ice packs and coolers
- Log books
- Personal gear (for all possible weather conditions, e.g., survival suits, raincoats, protective footwear, waders, gloves, etc.)
- First aid kit
- Equipment (checked and calibrated, properly loaded to avoid damage during transport, batteries charged, probes not damaged or dried, etc.)
- Camera or video equipment as required
- Laboratory requisition forms (partially filled out)

Before going to the field:

- Contact a qualified laboratory to arrange for the required analyses

A recommended operating procedure is to have the key equipment in a box or plastic “tote” which is dedicated to this activity. Appendix 1 of this chapter presents an example of a generic checklist.

2.2 Locating the Site in the Field

It is the responsibility of the field staff to locate all sampling stations accurately. Only if the same location is consistently sampled can temporal changes in the water quality be interpreted with confidence. Therefore, accurately written station location descriptions (that identify key landmarks and give the site a simple and unambiguous name) must be prepared on the first visit to every sampling site (see Appendix 2.1 for an example of a site identification guide sheet). Good photographic documentation is the best way of ensuring that each site is easily recognized.

A map that labels the sample sites should accompany the **site identification log book**. This can be in the form of a 3-ring binder with a 1:50 000 map. The basic site location data (see Appendix 2.1 - latitudes, longitudes, map sheet #, site identification #, etc.) should be incorporated into the Water Quality database (EMS in the case of BC Environment). In many cases, a detailed site map may be helpful in describing the station location. Global Positioning Systems (GPS) are becoming common tools for locating position of sites and are recommended for this purpose.

2.3 Field Notes/Observations

Good sampling practice always involves the use of detailed field notes. Specific information about seemingly unimportant facts such as the time of day or weather conditions are often important when interpreting data. A **field log book** (3-ring binder with water proof paper) for each project is mandatory (see Appendices 2 and 3 of this chapter for examples of data sheets). All field measurements should be entered directly into this field log book while in the field. All information recorded in the log book should be entered into the database immediately upon return from the field.

In addition to documenting standard conditions and measurements, field staff are responsible for noting any unusual occurrences. Any deviations from standard protocols (e.g., samples taken from a different location due to safety or access considerations or procedures used that differ from those outlined here) must be recorded in the database. Upon observing an anomalous condition, such as an unusual colour or odour of the water, excessive algal growth, indications that foreign substances have entered the system (oil slicks, surface films, etc.), or fish kills, the field investigator should take samples in addition to those required by the project design. The type of samples and their preservation should be consistent with the type of analyses that the investigator thinks are warranted by the prevailing conditions. If additional samples are collected, but not exactly at an established station, a new site location description should be accurately recorded and transferred to the database (EMS) as soon as possible. This information and additional samples will prove useful during the interpretive aspects of the study. The field books are important documents and efforts should be made to ensure they are properly archived.

3. Quality Assurance/Quality Control (QA/QC)

3.1 Field Quality Assurance

The field quality assurance program is a systematic process which, together with the laboratory and data storage quality assurance programs, ensures a specified degree of confidence in the data collected for an environmental survey. The Field Quality Assurance program involves a series of steps, procedures and practices which are described below.

The quality of data generated in a laboratory depends, to a large degree, on the integrity of the samples that arrive at the laboratory. Consequently, the field investigator must take the necessary precautions to protect samples from contamination and deterioration.

There are many sources of contamination; the following are some basic precautions to heed:

- Field measurements should always be made using a separate sub-sample which is then discarded once the measurements have been made. They should never be made on a water sample which is returned to the analytical laboratory for further chemical analyses. For example, specific conductance should never be measured in sample water that was first used for pH measurements. Potassium chloride diffusing from the pH probe alters the conductivity of the sample. Similarly, pH should not be measured from a sample that will be analyzed for phosphorus, as some pH buffers contain phosphorus. Use a separate bottle for water temperature if not *in-situ*. **Dissolved oxygen measurements (by DO probe) should be made *in-situ* rather than in a separate container.**
- Sample bottles, including bottle caps, must be cleaned according to the recommended methods and certified by the issuing laboratory as 'contamination free' (if pre-cleaned by the laboratory), for the intended analysis. Sample bottles which are pre-cleaned by the laboratory must **not** be rinsed with the sample water being collected. Bottles must be supplied with cap in place. Note that cleaned re-used bottles are not suitable for some trace constituents. If you are using a mixture of pre-cleaned, not pre-cleaned, and/or re-used bottles, label each bottle type to avoid confusion.
- Use only the recommended type of sample bottle for each analysis (see Appendix 4 of this chapter).

- Reagents and preservatives must be analytical grade and certified by the issuing laboratory to be contamination free (see Appendix 4). Containers holding chemical reagents and preservatives should be clearly labeled both as to contents and as to expiry date. No reagent or preservative should be used after the expiry date. Return expired reagents to the laboratory for proper disposal.
- If conditions dictate that samples from multiple sites be preserved at the same time (such as when returning to shore after sampling several deep stations), the possibility of adding the wrong preservative to a sample or cross-contaminating the preservative stocks should be minimized by preserving all the samples for a particular group of variables together. Colour-coded bottles and matching preservatives prevent mix-ups.
- The inner portion of sample (and preservative) bottles and caps must not be touched with anything (e.g., bare hands, gloves, thermometers, probes, preservative dispensers, etc.) other than the sample water and preservative. Remove caps only just before sampling and re-cap right away.
- Keep sample bottles in a clean environment, away from dust, dirt, fumes and grime. Bottles must be capped at all times and stored in clean shipping containers (coolers) both before and after the collection of the sample. Vehicle cleanliness is an important factor in eliminating contamination problems. During sample collection, store bottle caps in a clean, resealable plastic bag, not in pockets, etc.
- Petroleum products (gasoline, oil, exhaust fumes) are prime sources of contamination. Spills or drippings (which are apt to occur in boats) must be removed immediately. Exhaust fumes and cigarette smoke can contaminate samples with lead and other heavy metals. Air conditioning units are also a source of trace metal contamination.
- Filter units and related apparatus must be kept clean, using routine procedures such as acid washes and soakings in de-ionized water (see section 9). Store cleaned filter units in labelled, sealed plastic bags.
- Samples must never be permitted to get warm; they should be stored in a cool, dark place. Coolers packed with ice packs are recommended (most samples must be cooled to 4°C during transit to the laboratory). Conversely, samples must not be permitted to freeze unless freezing is part of the preservation protocol (Appendix 4). Cool samples as quickly as possible. A common mistake is to forget that a large volume of warm water soon melts a small amount of ice.

- Samples must be shipped to the laboratory without delay so that they arrive within 24 hours of sampling. Certain analyses must be conducted within 48 hours or within specified time limits set out in Appendix 4.
- Sample collectors should keep their hands clean and refrain from eating or smoking while working with water samples.
- Sample equipment and shipping coolers must be cleaned after each sampling round (see Section 9). Field cleaning is often not as effective as cleaning equipment at a support facility. Depending upon the analyte and concentration (i.e., metals or organics), it may only be possible to conduct effective cleaning procedures at a support facility, rather than in the field. Avoid using bleaches and strong detergents; specialty cleaning compounds are available.
- De-ionized water should not be used after 6 months (shelf-life period), and the containers should be clearly labeled with both the filling date and disposal date.

Note: Bottle cap liners of composite materials such as Bakelite must not be used due to high potential for contamination.

3.2 Quality Control

Quality control is an essential element of a field quality assurance program. In addition to standardized field procedures, field quality control requires the submission of blank samples to test: **1)** the purity of chemical preservatives; **2)** to check for contamination of sample containers, filter papers, filtering equipment or any other equipment that is used in sample collection, handling or transportation; and **3)** to detect other systematic and random errors occurring from the time of the sampling to the time of analysis. Replicate samples must also be collected to check that the sample is reproducible. Replicate samples allow the precision of the sampling and measurement process to be estimated, and are an additional check on sample contamination. The timing and the frequency of blank and replicate samples are established in the project design and will vary with each project. A minimum level of effort would be the use of blanks and replicates consisting of 10% of the samples. Another aspect of quality control is the use of certified or standard reference materials (CRM's or SRM's) and of spiked samples to assess laboratory process.

3.2.1 Blanks

Blanks are samples that do not contain the variable to be analyzed and are used to assess and control sample contamination. They are most often used to assess contamination of the trace measurements (metals and

nutrients) but should also be used on occasion to test potential contamination of the other analyses (such as general ions). Most blanks are carried through the entire sample collection and handling process so that the blank is exposed to the same potential sources of contamination as actual samples. Ideally, blanks should be prepared by the analytical laboratory in the appropriate sample bottles under clean conditions. Some of the blanks remain in the laboratory for analysis (laboratory blanks), while the remainder travel to the field for use as trip, field, equipment, and filtration blanks. Alternatively, blanks may be prepared in the field as outlined below.

3.2.1.1 Trip Blanks

Trip blanks are meant to detect any widespread contamination resulting from the container (including caps) and preservative during transport and storage. The recommended practice for organic parameters is to use carbon free de-ionized water for trip blanks.

PROTOCOL

- (a) Prior to a field sampling trip, one or more sample bottles for each type being used during the trip are selected at random, filled with de-ionized water that is provided by an analytical lab (preferably one different from the one samples are being sent to) and preserved in the field in the same manner as field samples (see section 7.2).
- (b) These bottles are capped and remain **unopened** throughout the sampling trip. They are transported to the field with the regular sample bottles and submitted with the field samples for the analysis of interest.

3.2.1.2 Field Blanks

Field blanks mimic the extra sampling and preservative process but do not come in contact with ambient water. Field blanks are exposed to the sampling environment at the sample site. Consequently, they provide information on contamination resulting from the handling technique and through exposure to the atmosphere. They are processed in the same manner as the associate samples (i.e., they are exposed to **all** the same potential sources of contamination as the sample). This includes handling and, in some cases, filtration and/or preservation.

PROTOCOL
(field blanks)

- (a) If the blank was prepared by the lab, then open the bottle to expose the de-ionized water to the air for as long as the sample was exposed when it was collected. Otherwise, when the blank is prepared in the field, pour de-ionized water into the pre-labeled field blank bottle and recap it (this simulates sample collection). Document whether it was a lab prepared or a field prepared blank.
- (b) Filter the sample as per the protocol outlined in section 7.1 (only if the associate sample requires filtration).
- (c) Add preservative as per section 7.2 (only if the associated sample requires preservation).
- (d) Ship to the lab with the remaining samples.

3.2.1.3 Equipment Blanks (prepared prior to the field trip)

A field equipment blank is a sample of de-ionized water that has been used to rinse sampling equipment. This blank (perhaps more properly described as a rinsate) is useful in documenting adequate decontamination of equipment. It is collected after completion of the decontamination process (washing) and prior to sampling.

PROTOCOL

- (a) Pour the rinse (de-ionized) water that was used for the last rinsing into a pre-labeled bottle that identifies the piece of equipment that was cleaned.
- (b) Submit the blank with the regular samples for analysis.

3.2.1.4 Filtration Blanks

Filtration blanks (or rinsate blanks) are de-ionized water that is passed through the filtration apparatus in the same manner as the sample. Analysis of the filtrate provides an indication of the types of contaminants that may have been introduced through contact with the filtration apparatus. Filtration blanks are also used as a check for potential cross-contamination through inadequate field cleaning techniques (rinsing of the apparatus with de-ionized water between samples). It should be done both at the start and again at some point between samples (after the apparatus has been cleaned

and immediately before the next 'real' sample is filtered). Each of these blanks is preserved in the same fashion as the associate samples.

PROTOCOL

- (a) Follow procedure outlined in section 7.1 (filtration).

3.2.2 Replicate Samples

3.2.2.1 Co-located Samples (field duplicate, triplicate, etc.)

Co-located samples are independent samples collected as close as possible to the same point in space and time and are intended to be identical. These samples are essential in documenting the precision of the entire sampling and analytical (laboratory) process.

For this procedure, simply follow (and repeat) the protocol outlined in section 4 (sample collection).

Note: Replicate samples have more information than either blanks or split samples, and are particularly recommended for QC studies.

3.2.2.2 Split Samples

Split samples are aliquots taken from the same container and analyzed independently by one or more laboratories. They are used to obtain the magnitude of errors owing to contamination, random and systematic errors, and any other variability, which are introduced after the time of sampling through analysis at the laboratory(ies). Split samples are commonly used to compare two or more laboratories. Care must be taken to ensure that the samples are split in a way to ensure homogeneity (a sample splitter must be used for samples containing suspended solids or effluents).

3.2.3 Spiked Samples (Field)

Spiked samples for each variable being tested are prepared by spiking aliquots of a single water sample with known amounts of the variable of interest. The information gained from spiked samples is used to reveal any systematic errors (or bias) in the analytical method. The spike solution is prepared by an analytical laboratory (preferably) or it can be prepared by the field staff (far less desirable) prior to the sampling trip.

PROTOCOL (spiked samples)

- (a) Collect the sample in a pre-labeled bottle as per section 4.
- (b) Add the aliquot of spike solution, recap the bottle, mix and then treat the sample as if it were a regular sample (i.e., preserve and filter if required).

3.2.4 Reference Samples

Reference samples are used to document the bias of the analytical (laboratory) process. There are two types of reference samples. The first, and simplest, is when an independent laboratory prepares a water sample with the addition of a known quantity of a variable of interest. In this case, the independent laboratory should provide calculated and measured concentrations on the variable.

The second type of reference material is a certified reference sample. It is obtained from a recognized national scientific body such as the National Research Council. The sample itself is an aliquot of a very large stabilized (may be preserved) batch sample that was collected from one place at one time. The batch sample has been subjected to a large number of analyses performed by independent laboratories using several different analytical techniques, but some reference materials are analyzed by different labs using the same methodology. Consequently, the distributing agency can provide a mean value and confidence interval for the variable of concern.

These samples are submitted blind to the analyzing laboratory along with the samples collected during a field trip. There is the option of submitting them blind (labeled as a regular sample) or non-blind with labeling that it is a certified reference material. The former is a more desirable QA tool.

4. Collecting Samples

Water samples are often obtained by filling a container held just beneath the surface of the water, commonly referred to as a dip or **grab sample**. Through the use of special depth samplers (such as a Van Dorn bottle), grab samples can also be obtained from deep waters. This is important as distinct thermal and chemical differences can occur throughout the water column. **Composite samples** are obtained by mixing equal volumes of discrete grab samples (collected at one point at regular time intervals or, collected from multiple points such as varying depths). A composite sample provides an estimate of average water quality conditions.

Note: If sample bottles have not been pre-cleaned by the laboratory, then they must be rinsed 3 times with either de-ionized water or sample water. The exceptions to this is when a sample is to be analyzed for suspended sediments, for contaminants likely associated with the suspended solids, or for oil and grease. In these cases, the bottles should not be rinsed with sample water as suspended particles or grease-like materials are retained on the interior surface of each bottle with each rinsing. For specialized analyses (trace metal, organics) and pre-cleaned bottles, containers should not be rinsed. Rinsing is not a recommended practice. Use of pre-cleaned bottles is recommended, where practical. Where bottles are rinsed, the rinsate should be discarded.

Special sampling and handling techniques known as “clean” and “ultra clean” methods are needed to achieve accurate results when measuring low-level trace metals in ambient waters. Clean methods are needed to quantify trace metals accurately when the concentrations are less than about 20 mg/L and down to 0.1 mg/L. Ultra clean methods are needed when the metal concentrations are less than 0.1 mg/L, as might be required for trace metals such as mercury, cadmium, or silver (Hunt et al., 1995). These methods are not in general use in British Columbia at this time, and detailed guidance on the methods has only recently become available. We expect that guidance on clean and ultra clean techniques will be added to the next edition of this field manual. In the interim, sample collectors should refer to the recent US Environmental Protection Agency report of the subject (USEPA, 1995).

4.1 Lake

Sample stations can be located either near-shore or in deeper waters (deeper sites are typically located over the deepest point of the lake). In general, the near-shore sites detect those effects that are associated with influences such as groundwater and run-off. Deep stations provide information about the water column, such as conditions associated with stratification (depth profiles). Additionally, near-shore sites tend to provide information on a relatively short time scale (days or weeks). The deeper sites allow for documentation on a seasonal or longer time frame.

4.1.1 Shore Sample

Sample collection at near-shore stations generally consists of grab samples at a specified location. It is critical that there be no deviation in location unless conditions at the site (e.g., severe weather, physical changes of the site, etc.) pose a threat to the sampler's safety. **If safety is threatened, then search for an alternative location nearby, or simply do not attempt to take the sample.** If an alternative location is found, then all details regarding the new site and the reasons why the alternative was necessary must be recorded in the field log book. This information should be entered into the database as soon as possible after returning from the field.

To avoid contamination from suspended sediments, the sample collector should preferably sample from a boat or a dock or, if that is not possible, should wade out past the point where wave action affects the lake bottom.

In most cases, this distance is not far from shore. But, in any case, **the sampler should not exceed a depth where there exists a reasonable possibility that water might enter the gum-boot or hip-wader.** This is particularly important during colder periods of the year when getting wet poses a health risk (such as hypothermia).

PROTOCOL

(for collecting shore samples)

- (a) Obtain labeled bottles and wade into the lake at the most accessible point.
- (b) Once you reach a sufficient depth (where bottom material will not interfere with the sample), stop and orient yourself towards the center of the lake.

If rinsing is required (see section 4, Collecting Samples), proceed from step (c), otherwise start at step (h).

- (c) Remove the lid and hold it aside without touching the inner surface.
- (d) With your other hand, grasp the bottle well below the neck. Lean out towards the center of the lake and, in one continuous motion, plunge the bottle beneath the surface and slowly force it through the water until it is partly full. This motion creates a current over the mouth of the bottle (such that water entering the bottle has not come in contact with your hand).
- (e) Replace the lid and shake the bottle vigorously.

- (f) Remove the lid and reach back towards shore to pour the water out.
- (g) Repeat steps (c) through (f) twice more before collecting the sample.
- (h) Remove the lid (without touching the inner surface) and grasp the bottle well below the neck. Lean out towards the center of the lake and, in one continuous motion, plunge the bottle beneath the surface and slowly force it through the water until it is full.
- (j) Return to shore and pack the sample(s) in a cooler until time and conditions permit for other necessary procedures (filtration and/or preservation, which should be done as soon as possible after the samples are collected).

4.1.2 Sampling from a Boat

The collection of deep water samples requires that at least one member of the sampling group be very familiar with boat operation and safety. **If the sampling trip involves the use of a boat, then the weather forecast or marine conditions should be obtained prior to departure from home. If conditions are poor, then the sampling trip should be postponed.**

4.1.2.1 Site Identification

Deep water sampling sites are marked with a buoy or referenced by easily identifiable features (preferably two) on shore. Reference points should be described (both in writing and with photographs) in the site identification log book. Once at the site, and if it is not too deep, anchor the boat (or tie it to the buoy) and wait until it settles with the bow (front) facing into the current (wind) before collecting the sample. If the water is too deep to anchor, then one person will have to maintain the location (with either the motor or with paddles) while the other person collects the samples and takes the field measurements.

4.1.2.2 Surface Water

PROTOCOL

(for collecting surface water)

- (a) The person at the bow (front) should always collect the samples. This is because the bow is the anchor point and, even in a slow moving water, the boat will drift so that the bow is upstream. In quiescent water the samples should be collected prior to anchoring and while the boat is slowly moving forward. These precautions reduce the potential of

contamination from the boat or motor. The person in the stern (rear) can be responsible for holding the boat's position (when not anchored), taking the field measurements (see section 6) and field notes. Contamination is not as much of a concern for field measurements.

- (b) Obtain a labeled sample bottle and remove the lid without touching the inside of the lid (or bottle!). If rinsing is required for the type of bottle, fill and rinse three times [see 4.1.1 (c) to (g)].
- (c) Reach out an arm length from the boat to take the sample. Ensure that the person in the stern is providing counterbalance (working over the opposite side of the boat).
- (d) Plunge the bottle under the surface and move it slowly towards the current (the direction the boat is facing). This should be done at a depth of approximately 0.5 meters.
- (e) Recap the bottle immediately and proceed with the next sample.
- (f) Samples requiring filtration and/or preservation (see sections 7.1 and 7.2) should be dealt with as soon as possible after returning to shore.

4.1.2.3 Deep Water

Lake water samples may be collected from any desired depth through the use of a **Van Dorn** (or similar) sampler (Figure 1). The Van Dorn bottle is designed for sampling at a depth of 2 metres or greater. A drain valve is provided for sample removal. Note that Van Dorn samplers are available in both horizontal and vertical configurations. The advantage of the vertical configuration is that the water within the open bottle is flushed out as the bottle is lowered, so one can be guaranteed the water collected was collected from the indicated depth. The advantage of the horizontal configuration is that a very narrow depth range is sampled. Vertical configurations are most commonly used. The horizontal configuration should be used when samples are taken near bottom at the sediment-water interface, or when samples are required from a narrow band of the depth profile (i.e., chemocline, thermocline).

The sampling sequence recommended is to obtain the field measurements first (temperature, DO, conductivity - see section 6). These are often necessary prerequisite for locating the depths from which the water samples should be taken (i.e., if three deep samples are required at a site then it might be necessary to know the depths of the major stratified zones - epilimnion, thermocline, hypolimnion).

Although operation of the Van Dorn bottle varies slightly depending on its size and style, the basic procedure is the same.

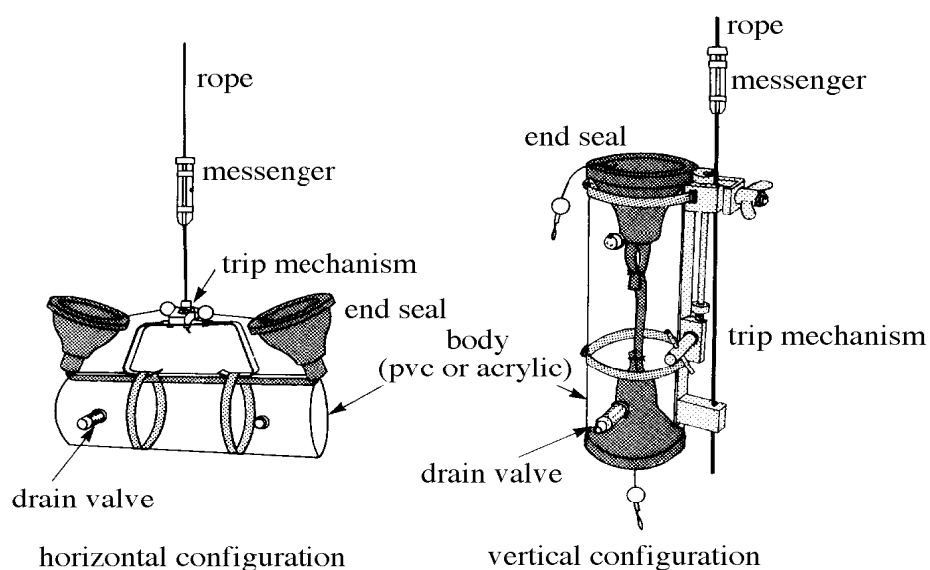

Figure 1. Van Dorn sampler

PROTOCOL

(for collecting deep water)

- (a) Ensure the sampling bottle is clean.
- (b) Open the sampler by raising the end seals.
- (c) Set the trip mechanism.
- (d) Lower the sampler to the desired depth.
- (e) Send the messenger down to “trip” the mechanism that closes the end seals.

- (f) Raise the sampler to the surface.
- (g) Transfer the water sample from the Van Dorn bottle to individual sample containers via the drain valve. Take care to avoid contact with the drain spout as contamination at this stage often occurs.
- (h) Rinse bottles 3 times (if they have not been pre-washed), and collect sample (see section 4.1.1).
- (i) Filter and/or preserve the samples as required once at shore.

4.1.3 Winter Sampling

Sampling in winter presents extra elements of danger. **Always proceed with caution over ice and do not jeopardize your safety.** Check the ice for thickness with a rod or ice chisel every few steps (ice should be a minimum of 3 to 4 inches thick). Ice over moving water can be of varying thickness, and the strength of the ice cannot be estimated from its apparent thickness near the shore. **Always have someone accompany (follow) you, wear a life jacket, and carry a length of rope (tied around your waist) to use as a life line. If the ice is unsafe, do not take a sample. Never take unnecessary risks.**

Note: Ice near the outlet of a lake is often thin, therefore, caution should be used when sampling this area of a lake. Additionally, ice thickness on reservoirs, where water levels fluctuate, can be variable.

In springtime, ice can be thick, but not strong enough to walk on (often called “Frazzle” or “corded” ice).

PROTOCOL

(for sampling through ice)

- (a) With safety considerations in mind, winter sampling locations should be as close as possible to the summer locations. The sites should be chosen where the water is known to be deep enough to avoid stirring up bottom sediments and to ensure that there is water movement under the ice at your selected spot. It is preferable to select a site where the ice is sagging rather than bulging.
- (b) Clear loose ice and snow from the sampling location, and drill through the ice with a hand or motorized auger. Keep the area around the hole clear of potential contamination (e.g., dirt, fuel,

oil, etc.). **At least one member of the sampling team should be familiar with the operation and safety of both motorized and hand operated augers.**

- (c) Remove all ice chips and slush from the hole, using a plastic sieve.
- (d) Use a Van Dorn (or similar) sampler to collect the sample (see section 4.1.2.3).
- (e) Do not allow samples to freeze.

Note: An alternative to this method would be to use the Through-Ice sampler described in section 4.2.4 - Winter Sampling on rivers (this technique does not allow the collection of samples that are deeper than 2 metres). Any deviations from the above protocol must be noted in the field log book.

4.2 River/Stream

The majority of samples collected from streams and rivers in British Columbia are grab samples taken near the surface at one point in the cross section of the flow. On rare, special occasions, more sophisticated multi-point sampling techniques known as equal-discharge-increment (EDI) or equal-width-increment (EWI) methods are used. Since these techniques are infrequently used they will not be discussed here, but further information about the protocols can be obtained from Clark and Shera, 1985.

Note: The collection of samples for the purpose of assessing the suspended sediment load in fast flowing waters requires specialized techniques/equipment. The equipment is not readily available, therefore, the protocols will not be discussed here. For information regarding the equipment and techniques, refer to Guy and Norman (1970) or Stichling and Smith (1968).

4.2.1 Access from the Stream Bank

Wherever practical, samples should be collected at mid-stream rather than near-shore. Samples collected from mid-stream reduce the possibilities of contamination (i.e., shore effects - back eddies, seepage from near shore soils, atmospheric components such as pollen concentrating in slow moving water, etc.). Samples should not be taken in back eddies or brackish waters unless required by the monitoring program objectives. The most important issue to consider when deciding where the sample should be collected from is **SAFETY**. If the flow is sufficiently slow that the collector can wade into the stream without risk, then the sample can be

collected at a depth that does not pose a threat (discretion is the key - **never wade into water that appears deep or fast flowing**). When conditions dictate that the sample be taken from the stream bank, deviations from the standard protocol should be accurately documented in the field log book and transferred to the database as soon as possible. **Samplers must be wary of non-visible bottom under turbid conditions.**

PROTOCOL

(for wading into flow)

- (a) Obtain labeled bottles and wade into the river downstream from the point at which you will collect the samples, then wade upstream to the sample site. This ensures that you will not disturb sediments upstream of the sample point. Attach safety line if conditions have any significant risk.
- (b) Stand perpendicular to the flow and face upstream.
- (c) Remove the lid and hold it aside without touching the inner surface. If rinsing is required for the type of bottle, fill and rinse three times (see section 4).
- (d) With your other hand, grasp the bottle well below the neck. Plunge it beneath the surface in front of you with the opening facing directly down, then immediately orient the bottle into the current. Avoid collecting surface scum and film.
- (e) Once the bottle is full, remove it from the water by forcing it forward (into the current) and upwards.
- (f) Replace the cap immediately.

PROTOCOL

(for sampling from the stream bank)

(when the current is too strong, water is too deep, or ice is too thin)

- (a) Secure yourself to a solid object on shore (with a safety harness and line if necessary). As a safety precaution, the second person must remain nearby while the first is collecting the samples.
- (b) Remove lid from a labeled bottle and place into a clean resealable bag (e.g., Zip Lock) so both hands can be used to take sample. If rinsing is required for the type of bottle, rinse three times.
- (c) Hold the bottle well below the neck or secure it to a pole sampler.
- (d) Reach out (arm length only) and plunge the bottle under the water with the opening facing directly down and immediately orient it into the current.
- (e) When the bottle is full, pull it up through the water while forcing into the current.
- (f) Immediately recap the bottle.

4.2.2 Access from a Bridge

Some sample stations are designed to be sampled from a bridge. This allows the collection of samples from the central flow of rivers where wading is not an option. The samples can be collected using an apparatus called a **multiple sampler** (Figure 2) that is lowered over the side of the bridge. Since the multiple sampler holds more than one bottle, it has the advantage of allowing all containers (therefore, all variables) to be sampled at the same time and at the same place. This allows for more precise cross-referencing among the variables. Other pieces of equipment for single bottles are also available and can be used in situations that are appropriate.

The precise location at which the sampling device is lowered from the bridge should be marked to ensure that the same section of the river is sampled each time.

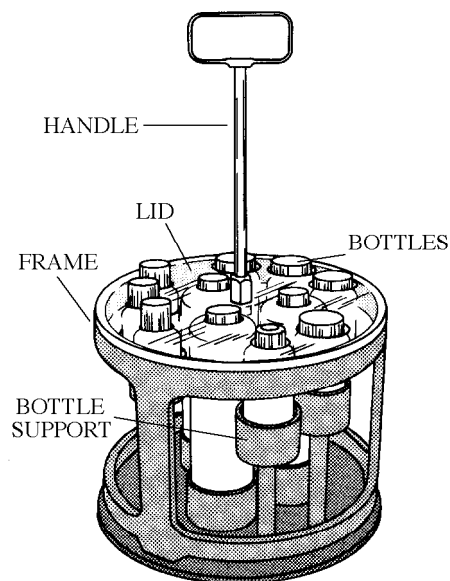

Figure 2. Generalized multiple sampler

PROTOCOL

(from bridge with multiple sampler)

- (a) Remove the lid (with handle) from the multiple sampler.
- (b) Secure all sample bottles (lids on) into the multiple sampler (as in Figure 2).
- (c) Refit the lid to the sampler.
- (d) Secure the free end of the sampler's rope to bridge before attempting to take the sample.
- (e) Remove lids from the sample bottles and place in a clean resealable bag (e.g., Zip Lock).
- (f) Whenever possible lower the multiple sampler over the upstream side of the bridge (side the that the water reaches first), being careful not to disturb bridge surfaces with the rope or sampler. This avoids

contamination of the sample from the bridge itself or substances falling into the water or into the open bottles from the bridge (e.g., fuel, oil, dust, wood chips, etc.).

- (g) Allow the sampler to submerge to the point that all the bottle openings are below the surface.
- (h) After a sufficient period has elapsed to fill all bottles, haul the sampler up, add preservatives where required, and recap each bottle before disassembling the sampler.

4.2.3 Sampling from a Boat

Due to the fact that fast-flowing waters pose a serious threat, it is essential that the person operating the boat be very experienced with river boating. Ideally, there should be three people along on the sampling trip when it involves boating on a river. Two people are responsible for collecting the samples, taking field measurements and recording field notes. The remaining person is responsible for boat operation only.

Sampling trips should start at the site that is most downstream and work upstream. If mechanical problems should arise then the current will work to your advantage and assist you to return to the vehicle.

PROTOCOL

(in flowing waters)

- (a) When a sample site is reached the boat operator idles into the current so as to maintain the boat in one location. Use a reference point on shore to do this.
- (b) The person in the bow is responsible for collecting the water samples (see section 4.1.2).
- (c) The third person is responsible for the field measurements (see section 6).

4.2.4 Winter Sampling

Due to the fact that flow patterns in rivers and streams are generally more complex than in lakes, there are additional safety factors to consider. Honeycombed ice and areas over rapids should always be avoided. Be aware that ice downstream from bridge supports may be thin as a result of

modified flow patterns and de-icing agents. At least two people must proceed onto the ice, one ahead of the other. The person in the rear should carry a rope and each must wear a life jacket.

Generally, winter sampling on rivers follows a similar protocol as for sampling lakes in winter (see section 4.1.3). The primary exception occurs when the ice is unsafe; when this is the case, sample stations that are accessible from a bridge are the only option.

When the ice is safe, there are two tools that are commonly used for the collection of water samples, the **Through Ice Sampler** (Figure 3) and the **Flip Sampler/Duncan Sampler** (Figure 4).

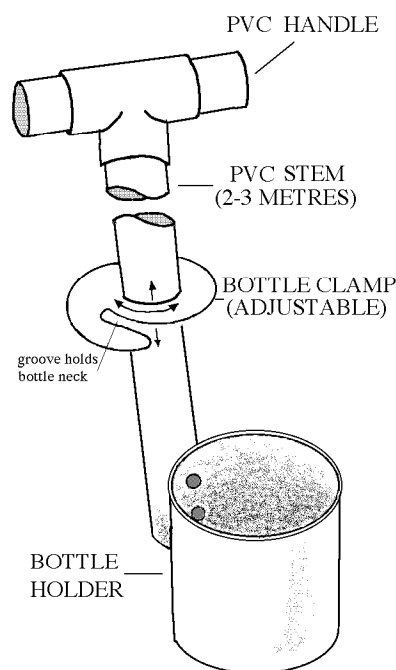

Figure 3. Through ice sampler

PROTOCOL
(Through Ice Sampler)

- (a) Clear loose ice and snow from the sampling location, and drill through the ice with a hand or motorized auger. Keep the area around the hole clear of potential contamination (e.g., dirt, fuel, oil, etc.). **At least one member of the sampling team should be familiar with the operation and safety of both motorized and hand operated augers.**
- (b) Remove all ice chips and slush from the hole, using a plastic sieve.
- (c) Load a pre-labeled bottle into the bottle holder of the **Through Ice Sampler** (Figure 3). Remove the bottle cap and insert stopper (with attached cord) into the bottle opening.
- (d) Lower the sampler and bottle through the hole until it is clear of the bottom of the ice surface, and into freely moving water.
- (e) Remove the stopper by pulling the cord, and allow the bottle to fill. For the bottle to fill in fast flowing water the sampler may have to be held at different angles.
- (f) Bring bottle back up and decant water into the appropriate sample bottles (rinsing if required). For low-level metals analysis, a separate pre-cleaned (acid-washed) collection bottle must be used in the through ice sampler.

There are a variety of unusual conditions that may be encountered in sampling through ice. There may be meltwater below the snow on the ice surface, or there may be a slushy stratum within the ice itself. If these or other conditions occur, they should be noted in the field book and a judgment made as to whether the sample is worth taking.

Note: In streams where the ice is not too thick (20 -50 cm), it may be possible to sample with shoulder length gloves and reach below the ice into the flowing water.

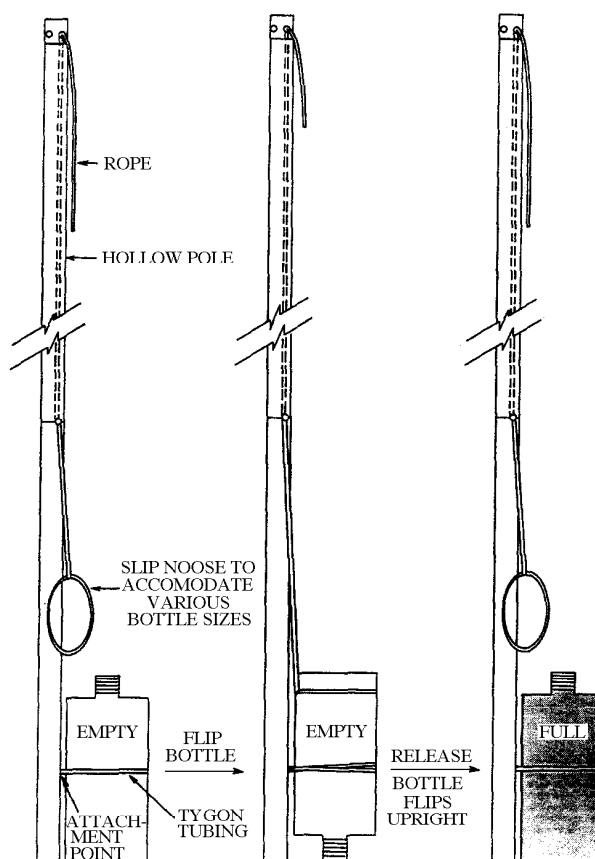

Figure 4. Flip sampler (Duncan sampler)

PROTOCOL
(Flip/Duncan sampler)

- (a) Clear loose ice and snow from the sampling location, and drill through the ice with a hand or motorized auger. Keep the area around the hole clear of potential contamination (e.g., dirt, fuel, oil, etc.). **At least one member of the sampling team should be familiar with the operation and safety of both motorized and hand operated augers.**
- (b) Remove all ice chips and slush from the hole, using a plastic sieve.
- (c) Load a pre-labeled bottle upright into the bottle holder (tygontubing) and rotate it so the mouth is facing down (Figure 4). Slip the noose over the bottom of the bottle.

- (d) Hold the rope and pole at the top while you lower the sampler through the hole to the desired depth.
- (e) Pull the rope to pivot the bottle so that the mouth faces upwards. Allow the bottle to fill and return it to the surface. Cap it immediately.

PROTOCOL

(from a bridge when ice is dangerous)

- (a) When river ice is thin, a hole of sufficient size to collect a sample may be produced by dropping a weight attached to a hand line.
- (b) Once the current has cleared the hole of debris, the protocol for sampling from a bridge (see section 4.2.2) should be followed.

Note: Extra care must be taken to avoid contamination in winter. De-icing agents such as salt can be easily transferred to the sample (particularly when working from a bridge).

5. Collecting Effluent and Receiving Water Samples

Effluent sampling has a particular series of protocols associated with it and this type of sampling is usually conducted by the waste discharge permittees. The conditions of sampling (frequency, site locations, etc.) are determined through consultation between BC Environment and the permit holder. These conditions are then outlined in the permit itself. **The sampling site must conform to Workers' Compensation Board Regulations and other applicable safety requirements, and be readily accessible under all expected weather conditions.**

An overview of the types of sampling and flow measurement procedures are presented in "Field Criteria for Sampling Effluents and Receiving Waters" (Bollans, et. al., 1989). The following protocols outline the steps required to ensure that the samples that arrive at the laboratory are representative of the true conditions in both the effluent and the receiving waters.

Blanks, as discussed in section 3.2.1, also apply to effluent sampling programs.

Appendix 4 of this chapter lists the container size and type, and preservation technique required for the individual parameters.

5.1 Effluent Stream

The sample must always be collected at the same location within the effluent stream to ensure that each is representative. Representative sampling locations occur where the effluent is well mixed in the river or stream (i.e., typically near the centre of the effluent stream in order to avoid boundary effects and biasing due to material which has a strong tendency to sink or float). Grab samples are generally specified when the concentration of a parameter under consideration is not expected to vary significantly with time; or when values associated with extreme events are desired or when the analyte is such that the procedure of compositing would destroy the sample integrity or representativeness (VOC's, oil and grease) where the sample must be shipped for the lab in the original sample bottles. Composite samples are generally specified when the concentration of the parameter under consideration is expected to vary with time (or location). The individual samples that make up the composite may be of equal volume or be proportional to the flow at the time of sampling. The compositing period is defined according to the terms of the Permit (i.e., daily, over a four-hour period, etc.).

Note: When sampling effluents or receiving waters, the collector must wear protective gear (gloves, goggles, waders, etc.).

When variability in effluent flow rates exists, flow proportional composite sampling is a technique that must be used. In order to accomplish this, accurate (preferably continuous) flow measurements must be made. Automatic sampling devices (to collect grab or composite samples) are acceptable providing that the sample is in contact with only components made of acceptable materials (stainless steel, glass, plastic or Teflon). Plastic is acceptable except where samples are taken for organic analyses. **Automatic** sampling devices must be equipped with a purge mechanism to enable the sample line to be evacuated prior to sample extraction. The velocity in the sampling line should be a minimum of 0.75 m/s to prevent the settling of solid material.

PROTOCOL (grab samples)

- (a) Obtain a pre-labeled sample bottle and remove the lid without touching the inner surface of either.
- (b) Grasp the bottle well below the neck and plunge it into the effluent. Ensure that your hand is always downstream of the bottle opening.

- (c) Recap the bottle and place it in a cooler containing a sufficient quantity of ice packs (twice the volume of ice to sample in the summer, one to one in the winter).
- (d) Once all the samples have been collected, process accordingly (see Appendix 3 of this chapter) and ship to the laboratory without delay (see section 8).

PROTOCOL

(composite sampling - flow proportional)

Note: Flow proportional composite sampling is necessary when effluent flow rates vary significantly (variations exceeding +15% of the daily mean more than 10% of the time) and will normally be specified as a condition of the Permit.

Follow the protocol outlined above for the actual acquisition of the sample. The only variable will be the quantity collected each time. The following is a hypothetical example of calculations for quantity collected:

If you are required to collect 1% of the effluent discharge (expressed per second) and the discharge is 10 L/sec then you would collect 100 mL. If the discharge doubles to 20 L/sec then in order to collect the required 1% you would have to collect a 200 mL sample.

It will be necessary to store component samples in an interim storage container over the prescribed composite period. This container must be made of acceptable materials, and the procedures for cleaning and re-use must conform to the protocols outlined in section 9. The sample must be kept cool (4°C) throughout the collection process.

Interim discrete samples should be preserved if required after they are taken, rather than waiting until the end of the composite period for adding preservative.

It is important to maintain a record of the volume and time of collection of the discrete subsample.

5.2 Receiving Waters

The sampling of receiving waters consists primarily of the same protocols and safety considerations as those discussed for ambient water sampling (see section 4). **The possibility of elevated levels of contaminants at some locations warrants further safety practices (see WHMIS and Workers' Compensation Board Regulations).**

The ambient conditions at each effluent discharge location dictate which sites are ideal as sampling stations. These sites, for testing the impacts of effluents on the receiving waters, are determined through consultation with the permittee. They will include the following considerations:

- A control site (receiving water in a location not affected by the discharge);
- A site intended to monitor discharge impacts after complete mixing with the receiving water;
- A site intended to monitor outside a defined initial dilution zone.

Refer to Bollans et al., (1989) for a description of dilution zones.

Refer to section 4 (Collecting Samples) for the protocols required for the acquisition of receiving water samples. Samples can be collected as either grab or composites. The rationale for composite sampling provided for effluents also applies to receiving waters. Receiving water flow variations are not usually significant over the sampling period, therefore, a flow proportional composite is not necessary.

6. Field Measurements

Field measurements involve the use of specialized equipment. Since different models are available for each variable, this section will discuss their use from a general perspective only. Field staffs are directed to the reference documentation provided by the instrument manufacturers. An equipment log book that documents instrument calibration, operation, and maintenance (yearly, at a service shop) records must be carried by the sampling staff at all times. This log book must contain information about each instrument available to the sampling group.

All field data are to be recorded in the field log book and entered into the database (e.g., EMS for BC Environment) as soon as possible upon return from the field.

6.1 Temperature

Temperature can be measured with an alcohol-filled thermometer or with an electronic thermometer that has been calibrated against a certified thermometer. All thermometers must be checked against a reference thermometer by a laboratory before use and annually thereafter. Thermometers that do not meet the data quality objective of the project (e.g., $\pm 0.5^{\circ}\text{C}$ of the true temperature) must be discarded.

PROTOCOL
(thermometer)

- (a) Measure surface water temperatures directly in the water, allowing the thermometer to come to equilibrium before recording the value.
- (b) For deep waters, collect a grab sample (e.g., with a Van Dorn - section 4.1.2.3) and decant some water into a 1 litre “field bottle” (never measure the temperature in a sample bottle that is being submitted to the laboratory for other analysis). Measure the temperature immediately, allowing the thermometer to come to equilibrium before recording the value.

Note: Ensure that the corresponding depth is identified for each temperature recorded in the field log book.

PROTOCOL
(temperature using meters)

Note: Many meters have the capacity to measure temperature. Typically, though, temperature is measured with a combined temperature-dissolved oxygen meter. Temperature changes that occur with depth strongly influence the solubility of oxygen and therefore, the two need to be correlated (% saturation of dissolved oxygen).

- (a) Calibrate the meter as per the operating instructions issued for each model.
- (b) Check meter temperature readings, both in air and in water, against a thermometer of known accuracy as a quality control measure. If the measures do not agree, the meter can be adjusted to the thermometer reading. This check should be repeated throughout the day to determine if the meter is “wandering”. All adjustments must be recorded in the field log book. Temperature data are typically recorded to the nearest 0.5 degree.
- (c) For depth profiles, record readings for increments of 1 - 2 metres. As a quality control measure, record the readings twice, once as the probe descends, and then again as it ascends.

6.2 Dissolved Oxygen (DO)

Dissolved oxygen can be measured by either chemical titration (Winkler method) or the membrane electrode method. Both have the potential of being accurate and reliable, but both methods require some training so that accurate measurements can be made. Meters provide a convenient and inexpensive way of measurement and are the most commonly used method. A well-calibrated oxygen meter membrane electrode system is preferred for obtaining a depth-profile of DO in a

lake or deep river. Sampling for DO measurements requires particular care, since any contact between the sample and the air will modify the results. If percent saturation is to be determined, then the water temperature must be measured at the same time and location. Additionally, barometric pressure or altitude are required to accurately determine percent saturation.

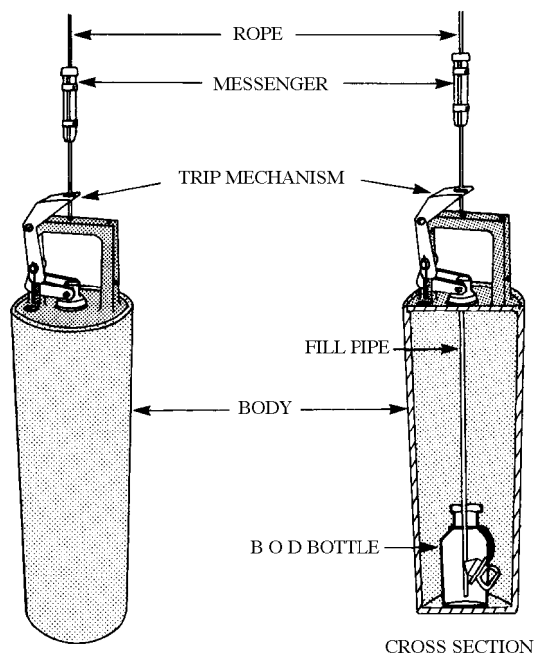

Figure 5. Dissolved Oxygen sampler

PROTOCOL
(Winkler method)

- (a) If a DO sampler (Figure 5) is available the sample can be collected directly into a BOD (biochemical oxygen demand) bottle which is used for DO sampling. This sampler flushes 3 volumes of water through the bottle before it is filled (minimizing air-water contact). If this sampler is used, then proceed directly to step (c) after acquisition of the sample. Otherwise, a Van Dorn bottle can be used to collect water samples for DO analysis. In shallow waters (where a water-bottle sampler cannot be used), use a hand pump or a bucket with a clamped drain tube installed at the bottom.

- (b) When the sample has been collected with a Van Dorn bottle or into a bucket, then transfer the sample to a 250 or 300 mL BOD bottle immediately. Allow the water to flow continuously through a delivery tube placed to the bottom of the bottle, taking care to prevent turbulence and bubble formation. Wait until at least 3 times the capacity of the sample bottle has overflowed before gently removing the tube (count the number of seconds for the bottle to fill initially then repeat twice).
- (c) Immediately and gently add the flocculating agent (typically a pre-measured powder pillow containing manganous sulfate and alkali-iodide-azide, available from HACH*). Insert stopper, being sure that no air becomes trapped in the bottle. Mix vigorously by inversion. Allow the precipitate to settle and shake vigorously again. At this point analysis can be suspended for up to 8 hours (when samples from all sites can be processed at the same time). Care must be taken to ensure that the samples are not exposed to light during the interim. Place in a cooler for transport to shore or laboratory.
- * If pre-packaged chemicals are not available, directions for preparation of the chemicals are given in *Standard Methods*.
- (d) Add 1 mL of concentrated sulfuric acid (H₂SO₄) with an automatic pipette by inserting the tip just below the surface of the sample. Carefully insert the stopper and shake the bottle until all of the precipitate has dissolved.
- (e) Measure 100 mL of the sample with a volumetric pipette and then transfer to a 250 mL Erlenmeyer flask. Touch the tip of the pipette to the side of the flask during delivery.
- (f) Titrate with 0.005M standardized sodium thiosulfate solution. Mix the sample during titration until a very pale yellow is observed.
- (g) Add 2 drops of stabilized starch solution, mix to get a uniform blue color, and titrate carefully but rapidly to a colourless end point. Record the volume of the titrant used in mL to two decimal places.
- (h) Calculate the concentration of dissolved oxygen in the sample as follows:

$$\text{mgO}_2/\text{L} = \frac{(\text{mL titrant})(\text{molarity of thiosulfate})(8000)}{(\text{mL sample titrated})(\text{mL of bottle} - 2/\text{mL of bottle})}$$

PROTOCOL

(DO meter - most common model YSI 57)

- (a) Follow instructions as per the manufacturer directions for storage, transportation, calibration, and use.
- (b) Obtain DO readings for increments of 1 - 2 metres both during the descent and the ascent of the probe. Allow probe to equilibrate (a steady reading on the meter) at each depth before recording the value. When passing through a zone of rapid temperature or DO change (a lake thermocline for instance), two to five minutes may be required for equilibration.

Notes:

1. **When membrane function deteriorates, it should be changed to avoid contamination of the sensing element. Air bubbles must not be trapped under the membrane.**
2. **When measuring DO in lake hypolimnia, do not allow the probe to remain in waters of low DO (<0.5 mg/L) as the probe will become damaged.**

Use high sensitivity membranes where possible. Service meters annually. Meters should never be stored for long periods with batteries inside. Probes need cleaning too. Attach tag indicating service date and battery change date. Always carry spare parts, including batteries.

A simplified but thorough set of instructions for operating and calibrating a DO meter should accompany the meter - preferably laminated in plastic.

6.3 Conductivity/Salinity

Conductivity and salinity can be measured with a specific conductance meter or a multi-purpose meter (e.g., a Hydrolab).

PROTOCOL

- (a) Follow instructions as per the manufacturer directions for storage, transportation, and use. Check the accuracy of the meter against a conductivity standard.
- (b) Obtain readings for increments of 1 - 2 metres both during the descent and the ascent of the probe. Allow probe to equilibrate at each depth before recording value.
- (c) Check readings periodically by having water samples measured in a laboratory.

Notes:

1. **Conductivity is a numerical expression of the ability of matter to carry an electric current. If the matter is an aqueous solution the term conductance is synonymous with conductivity. Either term is correct.**
2. **Since the conductance of solutions changes with temperature, a correction is made (usually an internal automatic correction by the instrument) to estimate the conductance at 25 C, called the ‘specific conductance.’ Note that not all meters have temperature compensation. Also meters having temperature compensation can be damaged such that the temperature compensation is not working. Therefore instrument maintenance checks should include evaluation of the temperature compensation.**

6.4 pH

Either an electronic pH meter or a multi-purpose meter is used to measure pH. Most pH meters require that the sample be brought to the surface, while the Hydrolab can be lowered through the water column. This measurement is accurate for the current conditions only in a fresh sample. Rapid pH changes that occur as a result of gas diffusion, biological activity, and chemical reactions dictate that the measurements be performed immediately.

pH electrodes are available for specific measurement of pH in waters of low ionic strength and high ionic strength. It is imperative when measuring pH in water of low ionic strength that an electrode designed for measurement in solutions of low conductivity or dissolved solids be used. Caution should also be taken that the pH electrodes are functioning correctly - ones in long term use or storage can lose the internal electrolyte and provide inaccurate data.

pH is a deceptively easy measurement to make but without understanding of how to use the equipment correctly, the risk of inaccurate data is very high.

PROTOCOL

(pH meter)

- (a) Follow the pH meter manufacturer’s instructions for storage and preparation of the electrodes.
- (b) Remove electrodes from the storage solution and rinse with distilled water. Electrode fill plug, if present, should be removed before taking readings.
- (c) In the field, calibrate the pH meter using two buffer solutions which will bracket the pH range of the samples [one at pH 7, one at acidic pH (4.0 or 5.0), or one at alkaline pH (8.0 or 9.0)]. Place the electrode in each solution

for at least 1 minute (rinse well with distilled water between buffer solutions). If the reading does not correspond to the value of the buffer solution, adjust the meter and record the discrepancy in the field log book. Repeat this process before the end of the sampling day. Samples should be at or near the temperature of the buffers used for calibration or the meter be equipped with a temperature compensation probe.

Note: Never calibrate with just a single buffer solution.

- d) Immerse the electrode directly into the surface water or into the field bottle (for samples collected from depth). Allow it to equilibrate before recording the value. Values are typically recorded to the nearest 0.1 pH unit.
- e) Check the field readings by having water samples measured periodically in a laboratory.

PROTOCOL

(pH using a multi-purpose meter)

Note: These meters have automated internal calibration mechanisms that must be checked at time of overhaul maintenance, and the probes must be calibrated for each parameter.

- (a) Follow instructions as per the manufacturer's directions for calibration, storage, transportation, and use.
- (b) Obtain readings for increments of 1 - 2 metres both during the descent and the ascent of the probe. Allow probe to equilibrate at each depth before recording value.

6.5 Clarity

Water clarity in lakes is most commonly measured with a Secchi disc. The Secchi disc is a weighted disc, 20 cm in diameter, that is divided into black and white quadrants. The measurement is called the 'extinction depth'.

PROTOCOL

- (a) Lower the Secchi disc over the shaded side of the boat.
- (b) Record the depth at which the pattern of the disc is no longer observable. The disc should then be lowered beyond this depth to determine, when it ascends, the depth at which it reappears. Average the two depth readings to calculate the extinction depth.

- (c) Record the value in the field log book along with the weather and water surface conditions (e.g., cloudy, sunny, windy, surface chop, etc.). Measurements should be to the nearest 0.1 meter.

Note: Secchi disc readings should only be taken from 2 hours after dawn to 2 hours before dusk. During winter months, readings should only be taken between 10 A.M. and 2 P.M. Sunglasses should not be worn while taking the measurement.

6.6 ORP

Oxidation-Reduction potential (ORP) is most commonly measured with a multi-purpose meter (e.g., Hydrolab).

PROTOCOL

- (a) Follow instructions as per the manufacturer's directions for storage, transportation, calibration and use.
- (b) Obtain readings for increments of 1 - 2 metres both during the descent and the ascent of the probe. Allow probe to equilibrate at each depth before recording value.
- (c) As the meter approaches the lake bottom (use bathymetric maps or a depth sounder to assess depth), the readings may drop rapidly. At this point, take care that the probe does not contact the sediment.

6.7 Stream Flow

The most accurate measure of stream flow is achieved with a current meter used at multiple points along the cross section of the stream. However, simpler methods may be used if the flow estimates need only be approximate (cross-sectional area, a roughness factor, and floating object provide a very gross estimate of flow).

PROTOCOL

(current meter)

- (a) Follow flow meter instructions as per the manufacturer's directions for storage, transportation, calibration, and use.
- (b) Extend a measuring tape at right angles to the direction of flow and measure the width of the cross section. Record measurements on a data sheet. Leave the tape strung across the stream.

- (c) Divide the width into segments using at least 20 points of measurement. If previous flow measurements have shown uniform depth and velocity, fewer points may be used. Smaller streams may also require fewer points. Measuring points should be closer together where depths or velocities are more variable. Cross sections with uniform depth and velocity can have equal spacing.
- (d) Record the distance (from the initial starting bank) and the depth of each point.
- (e) Record the current velocity at each measuring point.

Note: Horizontal and vertical variation of stream velocity may influence stream-flow measurements. To correct for vertical differences, hydrologists have determined depths that can yield acceptable estimates of the mean velocity over a vertical profile. If the depth exceeds 0.8 m, it is recommended that velocities be measured at 20 percent and 80 percent of full depth and averaged to estimate mean velocity. In the depth range 0.1-0.8 m, take the velocity at 60 percent of the full depth (measured from the surface) as an estimate of the mean over the profile.

- (f) Calculate flow as a summation of flows in partial areas using the following equation:

$$q_n = \frac{v_n d_n (b_{n+1} + b_{n-1})}{2}$$

where:

q = discharge in partial area n (m³/sec)

v = average current velocity in partial area n (m/sec)

d = mean depth of partial area n (m)

b_{n+1} = distance from point to the following point (m)

b_{n-1} = distance from point to the preceding point (m)

PROTOCOL (floating object)

- (a) Measure stream width (*w* in meters) and average depth (*d* in meters). Width is width of the water exclusive of dry stream bed. The average depth must be estimated, but is typically 0.4 - 0.6 of maximum depth (for shallow streams and deep streams respectively).
- (b) Measure a three meter strip (*l*) along the stream bank that bisects the area measured in step (a) (very fast streams will require a strip longer than 3 m).

Choose a location where both flow and substrate are fairly uniform and representative of the stream reach. Curved areas should be avoided.

- (c) Toss a floating object (e.g., cork, twig, etc.) into the flow upstream of the three meter measure area. Time the float as it travels the three meter segment. Repeat this step five times to obtain a mean of the time interval (t expressed in seconds). It is recommended that you re-measure until you get 3 measurements very nearly the same.
- (d) Discharge is then calculated as follows:

$$q = w d l a / t$$

where:

q = discharge (in m³/second)

a = roughness coefficient (0.8 if rough [boulders], 0.9 if smooth [mud, sand])

7. Field Filtration and Preservation

When the sampling objective is to determine concentrations of dissolved metals, low-level nutrients (e.g., phosphorus), or chlorophyll a in a water system, the sample must be filtered through a non-metallic 0.45 μm membrane immediately after collection. The guiding principle is to filter and preserve as soon as possible.

7.1 Filtration

The field filtration apparatus recommended is a portable vacuum system designed for ease of use in the field, thereby minimizing the time between sample collection and filtration (Figure 6). When filtering more than one sample, always filter the samples in the order of lowest expected variable levels to the highest. This minimizes the risk of cross-contamination between samples.

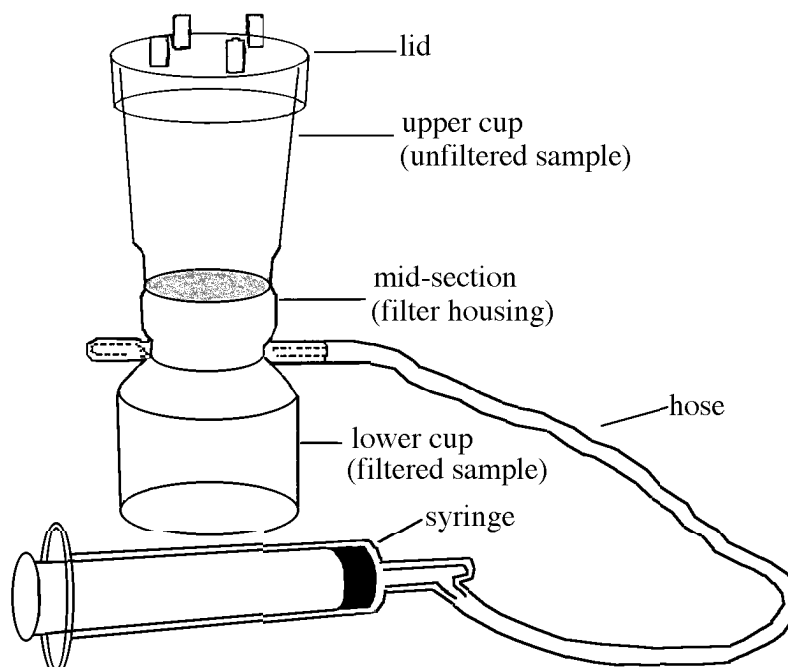

Figure 6. Filtration apparatus

PROTOCOL

- (a) Rinse filtration apparatus with de-ionized water.
- (b) With a pair of clean, non-metallic tweezers, place a filter paper on the surface of the mid-section of the filter apparatus. Assemble the apparatus as per Figure 6.
- (c) Pour 250 mL of de-ionized water in the top section of the apparatus.
- (d) Generate a partial vacuum by withdrawing the plunger of the syringe. Reject the initial filtrate (50 mL), then filter the remaining water through to the lower section of the apparatus.
- (e) Disassemble the apparatus and pour the filtrate into a labeled sample bottle. This is the first filter blank.
- (f) Reassemble the apparatus and filter first sample (as per instruction [d]) and pour the filtrate into a new labeled bottle. Always use standard amount of sample water (i.e., 250 mL) unless otherwise noted.

- (g) Rinse the entire apparatus twice with de-ionized water and proceed to next sample. **Always rinse the apparatus thoroughly between sites.**
- (h) At some point between samples (or after the last sample - if not filtering many samples), rinse the apparatus twice, change the filter paper, and filter 250 mL of de-ionized water. Transfer the filtrate to a labeled 'blank' bottle (e.g., 2nd filter blank or final filter blank).

Note: Other filtration techniques are also available and acceptable (e.g., Nalgene hand operated vacuum pump, disposable luer-lok syringes, etc.). Dedicate different sets of filtering apparatus for ambient, receiving water and effluent.

Note: The apparatus should be cleaned in a lab between field uses by soaking in dilute nitric acid solution followed by de-ionized water rinse and placing the dry and clean apparatus in a resealable bag (e.g., Zip Lock) for transportation.

7.2 Preservation

Many preservatives are considered hazardous materials and, therefore, the regulations outlined by WHMIS (Workplace Hazardous Materials Information System) must be adhered to. Read safety instructions and WHMIS material safety data sheets supplied for each preservative.

Deteriorated samples negate all the efforts and cost expended in obtaining representative samples. In general, the shorter the elapsed time between collection and analysis, the more reliable the analytical results.

Bulk dispensers for preservatives are not recommended due to the risk of contamination and deterioration over time. Preservatives should be pre-packaged in the laboratory in single-sample vials or ampoules to reduce the risk of contamination. Each of these ampoules should be labeled and have an expiry date beyond which they must be discarded in accordance with WHMIS regulations.

Note: Never use vials having Bakelite, or like material, as filler behind the cap liner of the lid.

Refer to Appendix 4 of this chapter for the quantity and type of preservative required for each individual analysis. Avoid pouring preservative down inside surface of sample bottle.

PROTOCOL

- (a) Before beginning, put on latex gloves and safety glasses or goggles.
- (b) Add preservatives to those samples which need preservation, being sure to match each preservative with its similarly labeled sample bottle. Preservative containers must not come in contact with the sample or inside of the sample bottle/lid. Minimize the length of time that the sample or preservative is exposed to the atmosphere.
- (c) Recap sample bottles tightly and invert twice to mix.
- (d) Recap the preservative bottles/vials tightly and place into a protective container. Ship these and latex gloves back to the lab with the samples for disposal.

Note: Consult WHMIS for recommended procedures for spill cleanup. Samplers should become familiar with WHMIS procedures before going into the field.

8. Shipping

The day's sampling schedule must be designed to ensure that the samples arrive at the shipping agency's terminal well before the end of business hours. Since some variables have very limited hold times (see Appendix 4), every effort must be made to avoid delays in shipping. The following is the procedure to be followed to maintain the integrity of the samples during transit.

PROTOCOL

Note: Ice packs should be used as opposed to loose ice or bagged ice. When loose ice melts, the contents of the cooler are free to shift, potentially allowing contamination of samples with melted ice water and/or breakage of glass bottles.

- (a) Pack the samples upright in the cooler with at least 1 (winter) to 2 (spring, summer, fall) times as much ice as the total volume of the samples. Ensure that the samples that are most likely to deteriorate are closest to the ice packs (i.e., those that are not chemically preserved). Also, ensure that the glass bottles are separated from each other by ice packs, plastic bottles, or clean packing material to prevent them from shifting, falling over and/or breaking.

- (b) Complete the laboratory requisition forms, enclose them in a sealed plastic bag, and then tape them to the inside lid of the cooler or place them in the cooler on top of the samples. The recommended minimum information that should accompany samples to the laboratory (on each requisition form) includes:

- Name of the source
- Site name
- EMS site numbers
- Date and time of collection
- Name of collector
- Field measurements
- Comments on sample appearance, weather conditions, and any other observations that may assist in interpreting water quality data

Additionally, a request should be made to the laboratory that they record the time and temperature of the samples at arrival (whenever samples requiring preservation by cooling to 4°C are shipped).

- (c) Seal the cooler with heavy duty packing tape to reduce the possibility of it accidentally opening and to prevent tampering with the samples. Coolers arriving at the laboratory with torn or absent tape alert the lab staff that tampering might have occurred during transit.
- (d) Attach a label prominently displaying the destination.

Note: If data on temperature on arrival is requested (to document that samples arrived at the laboratory at proper temperatures), a separate labeled bottle with water in it should be shipped in each cooler.

9. Cleaning Equipment

Equipment cleanness is an essential factor in ensuring that samples remain contaminant-free. All sampling devices (Van Dorn, multiple sampler, through ice sampler, tow nets, etc.) must be thoroughly cleaned and scrubbed with de-ionized water after each sampling trip. This process should be followed by two or three rinses with de-ionized water. The last rinsate should be collected and shipped for analysis as an equipment blank (see section 3.2.1.3).

Note: The Van Dorn sampler should be stored in the open position to prevent moisture from being trapped (might promote fungal or bacterial growth).

General cleanliness considerations include:

- Shipping containers (coolers) wiped free of dirt and rinsed with de-ionized water
- Vehicle neat and tidy
- Trailer, boat and motor free of aquatic plants before use on another body of water

The filtration apparatus must be soaked in an acid bath (10% HCl) and rinsed three times with de-ionized water. The final rinsate should be submitted periodically as an equipment blank.

Equipment used for ambient sampling should not be used for effluent sampling. Each type of sampling should have equipment dedicated to that use.

10. Sources of Further Information

American Public Health Association, American Water Works Association, Water Environment Federation. Standard Methods for the Examination of Water and Wastewater. 1992. 18th edition. *Edited by:* Greenberg, A.E., Clesceri, L.S., Eaton, A.D., and Franson, M.A.H. *Published By:* American Public Health Association.

Bollans, R.A., Crozier, R., and McQuaker, N.R. 1989. Field Criteria for Sampling Effluents and Receiving Waters. Waste Management Branch, Ministry of Environment, Lands and Parks.

Clark, M.J.R. and Shera, W.P. (*Editors*). 1985. Methods for Aquatic Data Collection in Environment Canada. 1983. Sampling for Water Quality. Water Quality Branch, Inland Waters Directorate, Ottawa.

Guy, H.P. and Norman, V.W. 1970. Field Methods for Measurement of Fluvial Sediment. U.S. Department of the Interior.

Horner, R., Bloom, N., Crecelius, E., and Brown, S. 1991. Recommended Protocols for Measuring Conventional Water Quality Variables and Metals in Fresh Water of the Puget Sound Region. *In: Puget Sound Estuary Program, Recommended Guidelines for Measuring Selected Environmental Variables in Puget Sound*.

Hunt, C.D., Lewis, D.A., and Lasorsa, B. 1995. Trace Metal Clean Sample Collection, Handling, and Analysis. A Short Course. Second SETAC World Congress, Vancouver BC, November 5, 1995. Batelle Ocean Sciences and Batelle Marine Sciences Laboratory.

- Lynch, A.J. and van Aggelen, G. 1994. Guidelines for the Collection and Analyses of Water and Wastewater Samples for Legal Evidence. Laboratory Services, Environmental Protection Department. Ministry of Environment, Lands and Parks. 12p. + appendices.
- Ontario Ministry of Environment. 1991. Draft Protocol for the Sampling and Analysis of Industrial/Municipal Wastewater, ISBN 0-7729-8970-2. Laboratory Services Branch, Ontario Ministry of Environment, ON.
- Ryan, A.L., Wade, N.L., Thorp, A.C., and Webber, T.N. 1991. Water Sampling Field Operation and Safety. British Columbia and Canada Water Quality Monitoring Agreement.
- Stichling, W. and Smith, T.F. 1968. Sediment Surveys in Canada. Inland Waters Branch. Department of Energy, Mines and Resources. Ottawa.
- United States EPA. 1986. Puget Sound Protocols. Prepared by Tetra Tech Inc. for the USEPA and the U.S. Army Corps of Engineers, Seattle, WA.
- United States EPA. April 1995. Method 1669: Sampling Ambient Water for Trace Metals at EPA Water Quality Criteria Levels. Office of Water. EPA 821-R-95-034.
- USEPA. Handbook for Sampling and Sample Preservation of Water and Wastewater. Report No. EPA-600/4-82-029 (or most recent edition).
- Water Pollution Control Federation. 1980. Wastewater Sampling for Process and Quality Control, Manual of Practice No. OM-1, Task Force on Plant Operational Control, WPCF, Washington, DC.
- Wetzel, R.G. and Likens, G.E. 1991. Limnological Analyses. Second edition. Springer - Verlag, New York.

11. Revision History

- October 10, 2013: This section republished without change. Notes added to Appendix 4: Sample Container, Preservation, and Hold Times for Water and Effluent Samples updated.

Appendix 1 Generic Field Checklist

(including water, sediments, biota and effluents)

General:

Log Books _____ Pencils _____
Cooler (with ice packs) _____ Felt Markers (waterproof) _____
Rope _____ Tape _____
Camera (film) _____ Requisition forms _____
Way bills _____ Shipping labels _____
De-ionized water (4L) _____ Squirt bottle _____
Resealable bags _____ maps _____

Labeled Sample Bottles:

General chemistry (1 L) # _____ General chemistry (2 L) # _____
Dissolved Metals # _____ Total Metals # _____
Total Organic Carbon # _____ Low-level nutrients # _____
Coliforms # _____ Sediments # _____
Zooplankton # _____ Phytoplankton # _____
Periphyton # _____ Invertebrates # _____
Tissue cups # _____ Macrophytes _____
Extras - two of each

Sampling Equipment (clean, in working order, batteries charged):

DO Sampler (BOD bottle, Winkler reagents) _____
Thermometer _____ DO meter _____
pH meter _____ Conductivity meter _____
Hydrolab _____ Secchi disc _____
Van Dorn, rope _____ Through Ice Sampler _____
Auger (bit sharpened, skimmer) _____ Spare probe membranes (repair kit) _____
Sediment grab _____ Sediment corer _____
Sieves _____ Zooplankton tow nets _____
Benthic invertebrate sampler (Hess, drift net, Surber) _____
Periphyton kit (cup, denture brush, baster) _____
Macrophyte sample kit (buckets, garbage bags, float tray, plant press, blot paper, herbarium sheets, newsprint, corrugated cardboard) _____

Filtration and Preservation Equipment:

Filter Pots _____ Syringe(s), Hose _____
Tweezers _____ 0.45/1.0 μ membrane filters _____
Preservative Vials with acid _____ Disposal Container (for used vials) _____
70% ethanol _____ Formalin _____
Lugol's solution _____ Magnesium carbonate _____
Boat Equipment:
Canoe (or boat) _____ Paddles _____
Motor _____ Fuel _____
Life jackets _____ Rope _____
Anchor _____ Tool kit _____

Personal Gear:

Lunch _____ Survival suit _____
Rain gear _____ Gum boots _____
Waders (hip, chest) _____ Sun screen _____

Safety:

WHMIS guidelines _____ First Aid Kit _____
Goggles (or safety glasses) _____ Rubber gloves _____
Hard Hat (for industrial sites) _____

Appendix 2 Site Identification

Appendix 2.1 Site Identification Guide

Appendix 2.2 Site Data Sheet (Lake)

Appendix 2.3 Site Data Sheet (River)

Appendix 2.4 Site Data Sheet (Effluent)

Appendix 2.1 Site Identification Guide

Lake / river name _____

EMS site number _____

Latitude _____

Longitude _____

Map sheet number _____ Elevation _____

Access road names or numbers _____

NOTES:

Distinguishing features

Best access point to water

Photograph/Access map

Appendix 2.2 Site Data Sheet (Lake)

EMS site number _____

Date _____

Time _____

Weather _____

Air temperature _____

Field Measurements:

Secchi depth _____

<u>Depth (m)</u>	<u>Temp</u>		<u>D.O.</u>		<u>pH</u>	<u>Cond</u>	<u>ORP</u>
	down	up	down	up			
0							
2							
4							
6							
8							
10							
12							
14							
16							
18							
20							
22							
24							
26							
28							
30 (or depths appr. to lake)							

Appendix 2.3 Site Data Sheet (River)

Site number _____

Date _____

Time _____

Weather _____

Air temperature _____

Field Measurements:

Water temperature _____

D.O. _____

pH _____

Conductivity _____

Flow / discharge _____

Stage (rising / falling) _____

Substrate type _____

Flow Data Measurements for Cross-Sections:

Appendix 2.4 Site Data Sheet (Effluent)

Site number _____

Date _____

Time _____

Weather _____

Site Observations

Effluent description _____

Site observation _____

Maintenance/process considerations _____

Appendix 3 Sampling For The Most Common Variables

Appendix 3.1 General Chemistry (including nutrients)

Appendix 3.2 Metals

Appendix 3.3 Carbon

Appendix 3.4 Chlorophyll *a*

Appendix 3.1 General Chemistry (including nutrients)

- 3.1.1 General chemistry (including acidity, alkalinity, chloride, colour, fluoride, hardness, nitrogen, pH, phosphorus, potassium, silica, sodium, specific conductance, sulfate and turbidity)

PROTOCOL

- (a) Collect sample for all nutrients (as per sections 4 & 5) in a pre-labeled, plastic bottle (250mL to 2L depending on how many tests needed).
- (b) Secure lid tightly and place in cooler with ice packs immediately.
- (c) Do not field filter or preserve.

- 3.1.2 Low-level nutrients (phosphorus and nitrogen)

PROTOCOL

- (a) Collect sample (as per sections 4 & 5) in a pre-cleaned (do not rinse), pre-labeled 250 mL brown glass bottle.
- (b) Field filter all low-level nutrient samples. Always return filtered sample to a new (clean) pre-labeled bottle.
- (c) Secure lid tightly and place in cooler immediately.
- (d) Do not field preserve.

Appendix 3.2 Metals

3.2.1 Total metals

PROTOCOL

- (a) Collect sample (as per sections 4 & 5) in a pre-cleaned (do not rinse), pre-labeled 500 mL plastic bottle.
- (b) Preserve the total metals samples with nitric acid (HNO₃ provided by the analytical laboratory in individual ampules).
- (c) Secure lid tightly and place in cooler immediately.
- (d) Do not field filter.

3.2.2 Dissolved metals

PROTOCOL

- (a) Collect sample (as per sections 4 & 5) in a pre-cleaned (do not rinse), pre-labeled 500 mL plastic bottle.
- (b) Field filter all dissolved metal samples. Always transfer the filtered sample to a new (clean) pre-labeled bottle. Field filtration is a procedure where contamination often occurs. Extreme caution should be exercised.
- (c) Once the sample has been field filtered and transferred to a new bottle, then preserve with nitric acid (HNO₃ provided by the analytical laboratory in individual ampules).

Secure lid tightly and place in cooler immediately.

Appendix 3.3 Carbon

3.3.1 Total organic/inorganic carbon

PROTOCOL

- (a) Collect sample (as per sections 4 & 5) in a pre-labeled 250 mL plastic bottle.
- (b) Secure lid tightly, ensuring that no air is trapped in the bottle, and place in cooler with ice packs immediately.
- (c) Do not field filter or preserve.

3.3.2 Dissolved organic/inorganic carbon

- (a) Collect sample (as per sections 4 & 5) in a pre-labeled 250 mL plastic bottle.
- (b) Field filter each dissolved carbon sample. Always transfer filtered sample to a new (clean) pre-labeled bottle.
- (c) Secure lid tightly, ensuring that no air is trapped in the bottle, and place in cooler with ice packs immediately.
- (d) Do not field preserve.

Appendix 3.4 Chlorophyll *a*

PROTOCOL

- (a) Collect sample (as per section 4) into a pre-labeled plastic bottle.
- (b) Secure lid tightly and immediately place in cooler with ice packs.
- (c) When all samples for the day are collected, filter (using a .45 micron membrane filter) an appropriate portion of the chlorophyll *a* sample. This can be done in the field or in the lab within a few hours of collection if the samples are kept dark and cool. The filtration should be done in cool temperature and subdued light (not on the tailgate at the boat ramp!). The amount of sample filtered depends on the density of the algae present (productive lakes may require only 50 mL, unproductive lakes may require 1 L to be filtered). **Always record the volume of sample that was filtered (both in the field log book and on the Laboratory Requisition Form).**
- (d) As the water sample is filtered, observe the filtration pressure or vacuum (<5psi) and the water level. When all but the last few mLs of water are drawn through the filter, rinse the top holding cup with de-ionized water and continue to filter. Before the rinse water is fully filtered, add 2-3 drops of MgCO₃ suspension (1g magnesium carbonate / 100 mL de-ionized water) and gently swirl the apparatus to distribute the MgCO₃. Magnesium carbonate is a buffer to stabilize the pH of the algal cells above 7. The cells are very sensitive to acid pH as the chlorophyll will then be degraded to other pigments like phaeophytins.
- (e) With clean tweezers, carefully remove the filter and place it in the center of a larger (9 cm) 'Whatman' filter paper. Fold the two papers in half and then in half again (with the smaller filter paper inside the larger). Secure the filter papers shut with a plastic paper clip. With a **pencil**, label the 'Whatman' filter paper as a chlorophyll sample. Also, for each sample, identify the date, site number and the volume of water filtered directly onto the 'Whatman' filter paper.

Note: Some brands of filter papers have throw-away plastic separators. On occasion, it has happened that people have confused these plastic separators with membrane filters separated by throw-away paper. Be sure you know which is the filter and which is the throw-away!

- (f) Place the filter paper in a pre-cooled dark bottle (amber glass, wrapped with aluminum foil and black tape - chlorophyll is very sensitive to degradation by light) that contains a desiccating agent (i.e., silica gel).

Note: Silica gel will take up water until it is saturated, at which point it must be rejuvenated by heating it in an oven for several hours. Ordinary silica gel is white, whether fresh or saturated. However, dye is often added to warn you when the gel has been saturated. Usually fresh silica gel is blue and completely saturated gel is pink. Partially saturated gel is both blue and pink (i.e., purple). Note that some brands of silica gel use other colours so be sure what color change you should expect. This is readily done by wetting a gel crystal to check the colour for saturated silica gel. Never use saturated silica gel.

Two common errors by untrained staff are to use saturated gel, or to attach the gel outside the bottle.

- (g) Pack the bottle containing all chlorophyll *a* samples in a cooler with ice packs (or dry ice) so that they remain frozen until they reach the analyzing laboratory.
- (h) Filters stored inside a dark bottle with dessicant can be stored in a deep freeze for a week or two but it is far preferable to ship them to the lab immediately.

Appendix 4 Sample Container, Preservation, and Hold Times for Water and Effluent Samples

TYPE OF ANALYSIS ^(1, 2)	STORAGE TEMP ⁽³⁾	CONTAINER TYPE	PRESERVATION	HOLD TIME ⁽⁴⁾ (days)
PHYSICAL & AGGREGATE PROPERTIES				
Acidity	≤6°C	P, G	none	14
Alkalinity	≤6°C	P, G	none	14
Colour	≤6°C	P, G	none	3
Conductivity	≤6°C	P, G	none	28
pH	≤6°C	P, G	none	15 min.
Solids (Total, TSS, TDS, Fixed, Volatile, etc.)	6°C	P, G	none	7
Turbidity	≤6°C	P, G	store in the dark	3
WATER - INORGANIC ANALYSIS				
Bromide	no req.	P, G	none	28
Chloride	no req.	P, G	none	28
Chlorate, Bromate	≤6°C	P, G	50 mg/L EDA	28
Chlorine, Total Residual (Free Chlorine)	none	P, G	none	15 min.
Chlorite	≤6°C	P, A, G	50 mg/L EDA	14
Cyanide, SAD and/or WAD	≤6°C	P, G	field NaOH, store in dark none	14 1
Dissolved Oxygen (Winkler Method)	≤6°C	G, BOD bottle	Winkler kit, store in dark	8 hours
Fluoride	no req.	P	none	28
Nitrogen, Nitrate + Nitrite	≤6°C	P, G	H ₂ SO ₄ none (BC MOE)	28 3
Nitrogen, Ammonia	≤6°C	P, G	H ₂ SO ₄ none (BC MOE)	28 3
Nitrogen, Nitrate	≤6°C, do not freeze	P, G	none	3
Nitrogen, Nitrite	≤6°C, do not freeze	P, G	none	3

Ambient Freshwater and Effluent Sampling

Nitrogen, Total Kjeldahl	≤6°C	P, G	H ₂ SO ₄ none (BC MOE)	28 3
Nitrogen, Total, Persulfate Method	≤6°C	P, G	H ₂ SO ₄ none (BC MOE)	28 3
Nitrogen, Total, Combustion Method	≤6°C	P, G	HCl none (BC MOE)	28 3
Phosphorus, Dissolved (Orthophosphate)	≤6°C	P, G	filter (field or lab)	3
Phosphorus, Total Reactive (Orthophosphate)	≤6°C	P, G	none	3
Phosphorus, Total Dissolved	≤6°C	P, G	filter, H ₂ SO ₄ none	28 3
Phosphorus, Total	≤6°C	P, G	H ₂ SO ₄ none (BC MOE)	28 3
Silica, Reactive	≤6°C, do not freeze	P	none	28
Sulfate	≤6°C	P, G	none	28
Sulfide	≤6°C	P or G	ZnAc / NaOH to pH >9	7
METALS				
Hexavalent Chromium	≤6°C	P, G	1ml 50% NaOH per 125ml none	30 1
Metals, Total	≤6°C	P, G	HNO ₃ ⁽⁷⁾	180
Metals, Dissolved	no req.	P, G	field filter 0.45um + HNO ₃ ⁽⁷⁾	180
Mercury, Total	no req.	G, PTFE	HCL or BrCL ⁽⁸⁾	28
Mercury, dissolved	no req.	G, PTFE	field filter 0.45 um + HCL or BrCL ⁽⁷⁾	28

Ambient Freshwater and Effluent Sampling

AGGREGATE ORGANIC ANALYSIS

AOX (Absorbable Organic Halides)	≤6°C	A, G	HNO ₃ , store in dark sodium sulfite if chlorinated, collect with no headspace	14
Biochemical Oxygen Demand (BOD)	≤6°C, do not freeze	P, G	none	3
Carbonaceous Biochemical Oxygen Demand (CBOD)	≤6°C, do not freeze	P, G	none	3
Carbon, Dissolved Organic	≤6°C	P, G	filter, H ₂ SO ₄ or HCl none (BC MOE)	28 3
Carbon, Dissolved Inorganic	≤6°C	P, G	field filter	14
Carbon, Total Organic	≤6°C	P, G	H ₂ SO ₄ or HCl	28
Carbon, Total Inorganic	≤6°C	P, G	none	14
Chemical Oxygen Demand (COD)	≤6°C	P, G	H ₂ SO ₄ (field or lab) none (BC MOE)	28 3
Chlorophyll <i>a</i>	Filters: freeze	Filter	field filter, store in dark	Filters: 28
	≤6°C	P, A, G	unfiltered, store in dark	2
Phaeophytin	Filters: freeze	Filter	field filter, store in dark	Filters: 28
Surfactants (Methylene Blue Active Substances)	≤6°C	P, G	none	3
Total Phenols (4AAP)	≤6°C	P, G	H ₂ SO ₄	28
EXTRACTABLE HYDROCARBONS				
Extractable Hydrocarbons (LEPH, HEPH, EPH)	≤6°C	A, G	HCl, H ₂ SO ₄ or Sodium Bisulfate none	14/40 7/40
Oil & Grease / Mineral Oil and Grease	≤6°C	A, G	HCL or H ₂ SO ₄	28
Waste Oil Content	≤6°C	A, G	none	28

Ambient Freshwater and Effluent Sampling

INDIVIDUAL ORGANIC COMPOUNDS

Carbamate Pesticides	≤6°C	A, G	Potassium Dihydrogen Citrate (solid), ~pH 3.8, 9.2-9.5 g/L, + 100 mg/L Na ₂ S ₂ O ₃ if chlorinated	28
			ChlorAC buffer, ~pH 3, 1.8mL/60 mL sample + 100 mg/L Na ₂ S ₂ O ₃ if chlorinated	28
Chlorinated and Non-chlorinated Phenolics	≤6°C	A, G	0.5g Ascorbic Acid / L + H ₂ SO ₄ or Sodium Bisulfate	14/40
			none	7/40
Dioxins / Furans	≤6°C	G, A	none	un-limited
Glyphosate / AMPA	≤6°C	A, G or Polypropylene	100 mg/L Na ₂ S ₂ O ₃ if chlorinated	14
Glycols	≤6°C	G	HCL or H ₂ SO ₄ or Sodium Bisulfate	14/40
			none	7/40
Halogenated Hydrocarbons (Semi-Volatile)	≤6°C	A, G	100 mg/L Na ₂ S ₂ O ₃ if chlorinated	7/40
Herbicides, Acid Extractable	≤6°C	A, G	HCL (optional), store in dark, 50 mg/L Na ₂ S ₂ O ₃ if chlorinated	14/21
Paraquat / Diquat	≤6°C	A, G	100 mg/L Na ₂ S ₂ O ₃ if chlorinated	7/21
Pesticides (NP, OP, OC)	≤6°C	A, G	none	7/40
Polychlorinated Biphenyls (PCBs)	≤6°C	A, G	none	un-limited
Polycyclic Aromatic Hydrocarbons (PAHs)	≤6°C	A, G	HCL, H ₂ SO ₄ or Sodium Bisulfate	14/40
			none	7/40

Ambient Freshwater and Effluent Sampling

Resin Acids, Fatty Acids	≤6°C	A, G	(0.5g Ascorbic Acid + 0.4g NaOH) / L none	14/40 7/40
Volatiles Organic Compounds (Trihalomethanes)	≤6°C	43ml G VOC Vials(2-3)	3 mg Na ₂ S ₂ O ₃ (see BC Lab Manual method for more details)	14
Volatiles Organic Compounds	≤6°C	43ml G VOC Vials(2-3)	200 mg NaHSO ₄ , or 3 mg Na ₂ S ₂ O ₃ Id chlorinated (see BC Lab Manual method for other options and details)	14

LEGEND

P = plastic	Ster = sterilized	no req = no requirement
G = glass	Solv = solvent cleaned	P&T = purge and trap vials
A = amber	Fc = foil-lined cap	
W = wide mouth	R = acid rinsed	
T = tissue cup	B = baked	

Note: The preservation acids/bases specify a pH endpoint (pH² or pH³12). The appropriate amount of preservative for a set of samples should be determined by titration on water samples collected specifically for that purpose. The amount of preservative needed should never be arrived at by titrating and measuring the pH of the actual sample!!! All preservatives should be high purity, lab approved materials.

The preservatives used should be supplied from the analytical lab in ampules. The lab will verify their purity and provide an expiration date, beyond which they should not be used.

Note: These are the preservation and hold times for the present (2013) BC MOE sample preservation & holding time requirements ^(1,2) contract laboratory for the Ministry. Different labs, organizations and protocols may differ, as may future laboratory procedures.

¹ A Director or an Environmental Management Act permit may specify alternate requirements.

² Refer to applicable BC Environmental Laboratory Manual methods for additional detail. Where differences exist between Lab Manual methods and this table, this table takes precedence.

³ Storage temperature applies to storage at the laboratory. For all tests where refrigeration at ≤6°C is required at the laboratory, samples should be packed with ice or cold packs to maintain a temperature of ≤10°C during transport to the laboratory. The storage of ≤8°C for microbiological samples applies during storage at the laboratory and during transport to the laboratory. To prevent breakage, water samples stored in glass should not be frozen. Except where indicated by "do not freeze", test results need not be qualified for frozen samples.

⁴ Hold Times: Single values refer to hold time from sampling to analysis. Where 2 values are given, the first is hold time from sampling to extraction, and the second is hold time from extraction to analysis.

- ⁵ Samples received from remote locations more than 48 hours after collection must not be tested.
- ⁶ Methanol extraction or freezing must be initiated within 48 hours of arrival at lab, to a maximum of 7 days from sample collection. Alternatively, samples may be frozen in the field if extracted within 14 days of sampling, or may be methanol extracted in the field.
- ⁷ Samples collected for dissolved metals analysis must be filtered in the field as soon as possible after collection (preferably within 15 minutes). This is particularly important for groundwaters where exposure to atmospheric conditions can trigger redox reactions that cause certain metals to precipitate (particularly iron). If precipitation of iron oxides occurs, many other heavy metals may precipitate or co-precipitate, potentially causing substantially low bias for many metallic elements. In extreme cases, some elements may be 100% removed from solution due to precipitation or co-precipitation caused by delay of filtration. Samples collected for dissolved metals analysis must be field filtered and then preserved with HNO₃.
- If not field-preserved, water samples collected for total metals analysis must be acidified at the lab in their original containers by addition of HNO₃ (within 14 days of sampling), then equilibrated at least 16 hours prior to sub-sampling or analysis (otherwise, qualify as "received unpreserved"). Not applicable to mercury.
- ⁸ Use only glass or PTFE containers to collect water samples for total or dissolved mercury. For total mercury, field-preserve with HCl or BrCl. Adding BrCl to original sample container at the laboratory within 28 days of sampling is an acceptable alternative for total mercury if samples are oxidized for 24 hours prior to sub-sampling or analysis. Samples collected for dissolved mercury analysis must be field filtered and then preserved with HCl or BrCl although BrCl is not recommended for use in the field for safety reasons.

Appendix 5 Effluent Sampling Checklist Guide

Location _____

Sample point _____

Date _____

NOTE: Ensure sampling point is agreeable to MELP and Permittee for determining compliance and in compliance to WCB regulations and safety requirements. Take samples for what is allowed by permit, or for what is requested. All sampling bottles should be clearly labelled and dated; and shipped to the designated lab immediately.

TEST PARAMETERS OF SAMPLE

Test Parameter	Sample Frequency and Type	Allowable Level

A. SAMPLE POINT

YES NO

Is the sample point:

- | | | |
|---|-----|-----|
| 1. accessible under all weather and tide conditions? | ___ | ___ |
| 2. near the centre of the stream? | ___ | ___ |
| 3. in a turbulent mixing zone (immediately downstream from a flow disturbance such as a pipe constriction, bend or flow control device)? (describe disturbance in Comments) | ___ | ___ |
| 4. at least 6 pipe diameters downstream from where two separate pipe streams combine (point of confluence)? | ___ | ___ |

Comments: _____

Appendix 5.1 Effluent Sampling Checklist

B. TYPE OF SAMPLE	YES	NO
1. Grab Sample	___	___
a) Does permit allow grab sample?	___	___
b) Is volume collected \geq 1 litre?	___	___
c) Is collection time \leq 15 minutes?	___	___
2. Composite Sample	___	___
a) Does permit allow composite sample?	___	___
b) Compositing period: _____	___	___
c) Is sampling frequency $>$ 4x / hour?	___	___
d) Are individual grabs of equal volume?	___	___
e) Is flow variation less than \pm 15% of daily mean more than 10% of the time?	___	___
f) Is flow proportional sampling performed?	___	___
3. Automatic Sampling Device (Grab or Composite)	___	___
a) Type: _____	___	___
b) Is the automatic sampling device equipped with a purge mechanism?	___	___
d) Is the velocity in the sampling line at least 0.75 m/s?	___	___
f) Do the components of the sampling device consist of acceptable materials for the parameter being sampled? (plastic for BOD and TSS analysis)	___	___
4. Continuous Sampling	___	___
a) Parameters sampled: _____	___	___
5. Split Sampling	___	___
a) Is the sample splitting device appropriate?	___	___
b) Has it been approved?	___	___
c) Was the splitter cleaned, as prescribed, prior to use?	___	___
d) Was the entire sample directed through splitter?	___	___

Comments: _____

Effluent Sampling Checklist

C. SAMPLER DESIGN AND OPERATION	YES	NO
1. Are sample bottles lab pre-cleaned?	___	___
2. Are components of storage container compatible with effluent parameter to be tested? (e.g. plastic for BOD, TSS; glass for oil)	___	___
3. Are all parts that come in contact with effluent cleaned regularly?	___	___
4. Are buckets, storage vessels, etc. that are reused		
a) rinsed 3 times with de-ionised water (W) or sample (S)? (if YES, specify whether (W) or (S) was used)	___	___
b) rinsed 3 times with acetone and once with de-ionised water, if organic parameters are sampled?	___	___

Comments: _____

D. SAMPLE PRESERVATION AND STORAGE	YES	NO
1. Is sample immediately cooled to 4°C (± 2°C), if required?	___	___
2. Is elapsed time for testing sensitive parameters ≤ 48 hours? (elapsed time for composite sample begins with the last sample collected)	___	___
3. Is sample filtered prior to preservation? (dissolved metals and nutrients)	___	___
4. Is preservation required?	___	___
5. Are blanks submitted with samples?	___	___
6. Parameters to be analysed: _____	___	___

Comments: _____

GROUNDWATER POLLUTION MONITORING

©Her Majesty the Queen in
Right of the Province of British Columbia

2013

All Rights Reserved

Table of Contents

1.	INTRODUCTION.....	287
2.	PRELIMINARY ASSESSMENT.....	287
	2.1 Potential Contaminants.....	287
	2.2 Hydrogeological Studies.....	288
3.	MONITORING SYSTEM DESIGN.....	288
4.	MONITORING WELL SPECIFICATIONS.....	289
	4.1 Well Design and Dimensions.....	289
	4.2 Materials.....	290
5.	WELL CONSTRUCTION.....	291
	5.1 Drilling Techniques.....	291
	5.2 Monitoring Well Development.....	292
	5.3 Hydraulic Assessment and Documentation.....	292
6.	SAMPLING PROGRAM.....	293
	6.1 Sampling Schedule.....	293
	6.2 Piezometric Records.....	293
	6.3 Field Measurements.....	293
7.	QUALITY ASSURANCE AND QUALITY CONTROL.....	294
8.	SAMPLE COLLECTION.....	295
	8.1 Sampling and Measuring Methods.....	295
	8.2 Immiscible Layers.....	296
	8.3 Purging.....	296
	8.4 Sample Extraction.....	297
	8.4.1 Organic Contaminant Sampling.....	297
	8.4.1.1 Volatile Organic Compounds.....	297
	8.4.1.2 Extractable Organic Compounds.....	298
	8.4.2 Inorganic Contaminant Sampling.....	298
	8.4.2.1 Specific Conductivity.....	298
	8.4.2.2 Metal Compounds.....	298
	8.5 Sample Preservation.....	299
9.	SOURCES OF FURTHER INFORMATION.....	300
10.	REVISION HISTORY.....	302

APPENDIX 1 RECOMMENDATIONS FOR SCREEN AND CASING MATERIALS IN SAMPLING APPLICATIONS	303
APPENDIX 2 DRILLING METHODS MATRIX	306
APPENDIX 3 TYPICAL MONITORING WELL DESIGN.....	307
APPENDIX 4 SAMPLING EQUIPMENT	308
APPENDIX 5 SAMPLE CONTAINER AND PRESERVATION CRITERIA	309
APPENDIX 6 GENERALIZED FLOW DIAGRAM OF GROUNDWATER SAMPLING STEPS	316

1. Introduction

The Environmental Protection Department (EPD) of the British Columbia Ministry of Environment, Lands and Parks (MELP) has, as part of its mandate, the regulation of permits related to industrial and domestic effluents, storage and transportation of special wastes, and refuse discharge sites. The ministry must also respond to unregulated discharges, whether accidental or intentional, that could result in contaminant loadings to groundwater.

These guidelines are intended to provide appropriate and effective methods to assess the extent of groundwater contamination and the potential for impact on human health and the environment.

Groundwater monitoring programs must be designed and implemented by qualified personnel to ensure consistent and representative sampling. All monitoring and sampling equipment must be operated and maintained in such a manner as to perform to design specifications for the duration of the monitoring program.

2. Preliminary Assessment

Groundwater monitoring at a site under investigation is intended to detect unacceptable groundwater contamination whether this results from a permitted operation or from an accidental or intentional discharge of contaminants (a spill). Acceptable contaminant levels are specified by the Manager and will generally be in accordance with the *Approved and Working Criteria for Water Quality - 1994*, published by the Water Quality Branch of the BC Ministry of Environment, Lands and Parks. The type of activity at the permitted site or the nature of the material spilled will dictate the parameters sampled for, and the hydrogeology of the area concerned will govern the sampling location(s), methods, and frequency.

2.1 Potential Contaminants

For a site under permit or regulation, the list of regulated parameters and site activities will provide the basis for requested analyses. For non-regulated activities and spill scenarios, investigation may be required to determine what contaminants and parameters need to be determined. This may entail, for example, analysis of the spilled material or tracking of the material through shipping or commercial documentation (e.g., TDG and WHMIS).

2.2 Hydrogeological Studies

The location and number of monitoring wells (piezometers) required to adequately describe hydrogeologic conditions will depend upon the site-specific geology, soil, and groundwater regime as well as the suspected character and quantity of the contaminant. Networks of monitoring wells are often developed in phases, with data reviewed at the end of each phase to determine if the hydraulics of the site are being adequately defined. A groundwater monitoring well network will consist of a sufficient number of wells, installed at appropriate locations and depths, to yield samples that represent the quality of both ambient groundwater and leachate which has passed under or through the affected area of the site.

A groundwater monitoring program for a permitted site is a long term project. For example, a landfill groundwater monitoring program may extend through the entire post-closure period (a minimum period of 25 years) as well as during the operational period of the landfill. Nonpermitted sites may also require extended monitoring depending on the type of contamination (solubility, etc.) and the potential for impact on human health and the environment. As a consequence, planning for the location and installation of monitoring wells in and around the sites should include consideration of both existing and anticipated site development as well as the type of contaminant plume involved and address any predicted changes in groundwater flow.

3. Monitoring System Design

Hydrogeological investigations are required to determine the appropriate location and depth of monitoring wells. Nearly all hydrogeological investigations include a subsurface boring program which is necessary to define the hydrogeology and local geological conditions of the site. For boreholes that will be completed as monitoring wells, generally at least one groundwater sample should be collected from each lithological zone. (If drilling in contaminated materials, care should be taken to prevent contaminants from migrating vertically into clean strata). Boreholes that will not be completed as monitoring wells must be properly decommissioned (e.g., back filled with impervious material if necessary).

The number of boreholes required to delineate hydrogeological conditions will vary from site to site. On average, seven holes are drilled for sites with a relatively uniform lithology. There are exceptions; for example, some sites in British Columbia (former Expo lands and a dichloroethane spill near Fort Langley) have required over two hundred test holes, but these would generally be installed over a multi-phase program.

Considerations for selecting drilling sites should include (Piteau, '90):

- Bore holes located both up and down gradient with respect to groundwater flow from the suspected contaminated source

- Bore holes drilled in both permeable zones and zones where low permeable material is expected
- Networks of holes to construct hydrogeologic and contaminant plume profiles.
- Completion of test holes as permanent monitoring wells.

The uppermost aquifer and confining layers should be characterized by installing piezometers to determine:

- The direction and rate of groundwater flow (both horizontal and vertical)
- Seasonal/temporal, natural, and artificially induced short-term and long-term variations in groundwater elevations and flow patterns, contaminant concentrations and free product thicknesses.
- The hydraulic conductivity of the stratigraphic units at the site
- The lateral and vertical extent of contamination.

4. Monitoring Well Specifications

Groundwater monitoring wells are installed in and around a site to allow measurement of water level and sampling of groundwater for contaminants.

Monitoring well construction materials are discussed in section 4.2. Although well construction is not, strictly speaking, part of the sampling protocol, improper drilling techniques and screen slot selection may bias subsequent analyses regardless of the care taken to avoid contamination during collection of the sample.

4.1 Well Design and Dimensions

Monitoring wells must include a protective casing that preserves the integrity of the borehole and if required, be monitored to meet design specifications. This casing must be screened and packed with a filter to enable the collection of sediment-free groundwater samples. Well screen slot size should be based on hydrologic characteristics and on the grain-size distribution of the aquifer being monitored. The primary filter pack material should be a chemically inert material, well rounded, and uniform in size. The most common filter packs are made of sand or gravel. At least two inches of filter pack material should be installed in the annular space and sealed above the sampling depth to prevent contamination of samples. The seals and grout are generally constructed of bentonite and/or cement, as appropriate. Refer to Appendix 3 of this chapter for typical monitoring well design.

Monitoring wells can range in diameter from 25mm-150mm, with a 50mm diameter the most common. The diameter of a monitoring well should be the minimum practical size which will allow for proper development of the well screen and operation of the sampling device. Large diameter wells (greater than 50 mm) are not recommended as they hold large volumes of water which require more purging prior to sampling.

Piezometers should have as short a screened interval as possible for measuring total hydraulic head. Screens can range in length from a few centimetres to tens of metres. They are typically found to be between 0.5-1.5 m in length and are sealed in intervals slightly longer. Short screens provide discrete data while long screens have limited application. Longer screens obtain a sample that represents the “average” chemistry of water flowing through the aquifer and is a function of all of the different heads over the entire length of the screened interval.

Well screens longer than 1.5 metres may be justified. Examples are provided below; however, in such cases, wells with smaller screen lengths must be installed in nest formations to facilitate contaminant sampling.

- When natural water level fluctuations dictate a longer screen length (this may be better accommodated by a longer casing);
- When the interval monitored is slightly greater (thicker) than the appropriate screen length;
- When a homogeneous, extremely thick aquifer (i.e., greater than 90m) is being monitored, a longer screen (i.e., 6m), representing a comparatively discrete interval, may be necessary;
- Where soils with extremely low hydraulic conductivity are encountered;
- When monitoring a significant thickness of a light nonaqueous phase liquid (NAPL) on top of groundwater; or
- When monitoring NAPLs in an aquifer with significant seasonal water table fluctuation.

4.2 Materials

Each monitoring program should be considered unique when determining monitoring well construction materials. The choice of construction material will depend on the following factors: cost, availability, strength, and chemical and physical compatibility with groundwater and potential analytes. There are a variety of materials on the market with a wide price range. An assessment of material suitability for monitoring well construction is summarized in Appendix 1.

Due to availability and cost, polyvinylchloride (PVC) tends to be the most common choice. Most often, the piezometer is constructed of 50 mm diameter threaded, sealed PVC pipe with fine slotted manufactured well screens. However, recent studies investigating the absorption and release of organic compounds by rigid PVC have led the EPA to recommend, for EPA protocol sites, the use of well construction materials made of (PTFE) or stainless steel as opposed to PVC. Unfortunately, the costs of stainless steel and PTFE are considerably more expensive than PVC (see Appendix 1). In

certain cases it may be advantageous to design a well using more than one type of material. For example, where stainless steel may be preferred in a specific chemical environment, costs may be saved by using PVC in non-critical portions of the well.

Additional components required for the monitoring well (e.g., primary filter pack, riser, etc.), including joints/couplings, should be comprised of material that will not alter the quality of water samples for the constituents of concern. With the exception of the primary filter pack, the additional components are commonly fabricated from PVC, stainless steel, fibreglass, or fluoropolymer. Materials recommended to prevent joints from leaking include PTFE tape for tapered thread joints and o-rings with a known chemistry for flush joint threads. Glued or solvent joints of any type are not recommended, especially where analysis for organic contaminants is anticipated, since glues and solvents may alter the chemistry of water samples (ASTM D5092-90). For further information regarding size specifications and/or installation procedures, refer to ASTM Designations: D5092-90.

5. Well Construction

5.1 Drilling Techniques

Well drilling methods commonly used in BC include air rotary, sonic drilling, cable tool, hollow stem auger, and Becker hammer. The method selection is usually dictated by the anticipated ground conditions and the availability of equipment.

Whenever feasible, drilling procedures should be utilized that do not require the injection of water or drilling fluids into the borehole, and that optimize cuttings control at ground surface. Where the use of drilling fluids is unavoidable, the selected fluid should have as little impact as possible on the water samples for the constituents of interest (ASTM D5092-90).

Preliminary laboratory testing of the fluid may be useful in determining potential for contamination. Furthermore, extreme care must be exercised when drilling at or near a geo technical liner (a punctured liner would severely impact the effectiveness of a leachate collection system). It is the responsibility of both the driller and the permittee to ensure that the monitoring well is installed correctly and the integrity of the liner is maintained.

A matrix of appropriate drilling methods for use in British Columbia is presented in Appendix 2. A further reference of greater scope and detail is *The Handbook of Suggested Practices for the Design and Installation of Ground-Water Monitoring Wells* (Aller et al., 1989). It provides a matrix that uses a rating system to establish the desirability of a drilling method based on the general hydrogeologic conditions and well design requirements.

5.2 Monitoring Well Development

Monitoring well development is intended to correct any clogging or compaction that may interfere with water quality analysis, to improve hydraulic characteristics and to restore ground water properties disturbed during the drilling process. Monitoring well development should follow the installation process and continue until the water is representative and free of the drilling fluid cuttings, or other materials introduced during the drilling process. Representative water is assumed to have been obtained when pH, temperature, and specific conductivity readings have stabilized and the water is virtually clear of suspended solids (ASTM D5092-90). Methods of development include mechanical surging, over pumping, air lift pumping, and well jetting.

The combined use of a jetting tool with air-lift pumping is a particularly effective development method. Mechanical surging, as with a surge block or large bailer, can also be used but is less effective (Sabel and Clark, '85). A well recovery test should be carried out immediately after and in conjunction with well development.

5.3 Hydraulic Assessment and Documentation

All constructed piezometers should be tested to determine the hydraulic conductivity of the formation, and to determine if they are sufficiently responsive to the hydraulic flow system to provide reliable monitoring data. The local groundwater flow system can be determined by installing piezometers to measure the hydraulic heads at various points in the system.

At least three piezometers in a triangular array are needed to define the horizontal hydraulic gradient and direction of groundwater flow in simple flow systems. Vertical gradients are determined with nested piezometers. (Nested piezometers are also needed to delimitate vertical contaminant concentration gradients.) In areas of complex geology, additional piezometers are needed since the flow medium will be heterogeneous and will result in a distorted hydraulic head distribution (Piteau, 1990).

Hydraulic head measurements should be collected at different depths, as well as at different locations on the site. Contours of the hydraulic heads will

indicate which areas are located downgradient of the site and are, therefore, at risk of becoming contaminated, and which areas are located upgradient of the site and could thus provide background data. This information is useful for selecting appropriate monitoring sites.

6. Sampling Program

6.1 Sampling Schedule

Sampling frequency is based on the potential human health and environmental impact and on the rate of contaminant movement. Groundwater velocities are usually much less than those of surface waters and, therefore, sampling intervals may be longer. Monitoring parameters and frequency of sampling are site specific.

Water levels should be monitored on at least the same frequency as the regular chemical monitoring. Quarterly monitoring of water levels in all monitoring wells is commonly required to determine seasonal variations in groundwater flow.

A sampling schedule should be developed that takes into consideration the various conditions that influence the extent and direction of groundwater flow and the rate at which potential contaminants migrate into and with the groundwater. Some conditions that influence contaminant transport to the water table are precipitation, temperature, soil permeability, and soil type(s).

6.2 Piezometric Records

It is generally assumed that the flow system of a groundwater system is a steady state situation and that fluctuations in head are minor in comparison to total head drop from recharge to discharge. However, for localized aspects of a system it may be important to quantify and document groundwater level variation. In these cases, piezometric measurements should be recorded on a regular basis to characterize seasonal fluctuations. For wells located near the ocean, tidal effects may be significant and, as well, there is the potential for salt water intrusion to cause variation in chemical composition.

6.3 Field Measurements

Regular monitoring of traditional “field parameters” such as odour, colour, pH, conductance, redox potential, and temperature, may provide an indication that a change in groundwater quality has occurred and that sampling for more extensive analysis is warranted.

7. Quality Assurance and Quality Control

Monitoring programs should include a quality assurance (QA) and quality control (QC) component in their design in order to provide confidence in the data obtained. Refer to the manual *Quality Assurance in Water Quality Monitoring* produced by Environment Canada, the Quality Control and Quality Assurance chapter of this manual (Part A), or the Quality Assurance section of *Ministry Methods Manual - Permittee Edition -1994*, produced by the EPD of BC MELP for the development and implementation of acceptable water monitoring programs. Laboratories generally have their own internal QC program consisting of regular testing of blanks, spikes, and laboratory duplicates.

A field QA protocol is necessary to verify the reliability and accuracy of the combined field sampling/handling and laboratory procedures and should include the following (Piteau, '90):

- Blind replicate samples: identical field samples are submitted under different sample identities to test for reproducibility of the sampling and analytical procedure (precision)
- Blind reference samples: reference samples (may be certified) are prepared to mimic authentic samples and are submitted under fictitious sample identities to test for analytical bias (accuracy)
- Spiked samples: a field sample is split and a known concentration of a contaminant is added to one-half of the sample to check for systematic errors (bias)
- Blank samples: laboratory reagent (distilled or deionized) water is carried through sample collection and handling (including preservation) to check for contamination, purity of preservatives and other systematic errors occurring from time of sampling

The contaminant concentrations in blanks should be recorded, and if concentrations are more than an order of magnitude greater than the detection limit for the parameter and the sample result is less than 5 times detection limit, the groundwater should be resampled to ensure QA and QC standards have been satisfied.

The laboratory should be contacted prior to sampling to ensure that sample handling, preservation, and shipping methods are appropriate. Sample storage time prior to laboratory analysis must not exceed allowable limits. Refer to Appendix 6 for a generalized flow diagram of groundwater sampling steps.

The calibration and maintenance of field equipment is also an integral component of QA/QC. All equipment must be kept clean and in good working condition, using the techniques described by the manufacturer. Calibrations, prior to the sampling event, should be performed under the same instrumental and chemical conditions as those that will exist at the sampling site. The frequency of calibration will depend on the accuracy requirements of the investigation and the stability of the instrument. To

ensure a high standard of QA/QC, monitoring personnel must be adequately trained and supervised.

Where a series of samples is to be collected using common equipment, sampling should begin with the (assumed) lesser contaminated sites and progress to sites with higher anticipated levels of contamination.

A log should be kept for each item of equipment to document calibration, exposure, maintenance, and service.

8. Sample Collection

8.1 Sampling and Measuring Methods

A sampling device is chosen based on the parameters that are to be monitored, the compatibility of the rate of well purging with well yield, the diameter of the well, and the depth from which the sample must be collected.

The cost, transportability and ease of use of the sampling device are also important considerations.

Appropriate measures are required to prevent cross contamination between wells during the sample collection procedure. For example, drilling equipment must be decontaminated between boreholes; sampling equipment must be decontaminated between each sampling event and, where appropriate, between specific parameter groups such as organic contaminants. Sampling equipment (including automated models) must be made of materials that are compatible with the type of contaminated groundwater being sampled and must not contribute or remove (e.g., by adsorption) any parameter of interest.

The routine parameters monitored in groundwater include pH, redox potential (Eh), dissolved oxygen (DO), specific conductivity, metals, ammonia nitrogen, chloride, and chemical oxygen demand (COD); other parameters may be added to this list on a site specific basis. The standard industry practice is to use a flow through cell to measure the DO, pH, and conductivity. Other parameters are measured with static probes or parameter specific test kits. Routine quarterly sampling and in-situ monitoring will establish the presence of any trends, identify any statistically significant changes, locate contaminant plumes and, most importantly, identify those parameters with values that fail to meet the applicable criteria.

Statistically significant refers to a statistically significant increase or decrease from background values or exceedance of a compliance level for each parameter or constituent being monitored. It is the responsibility of the owner/operator or his agent to choose an appropriate statistical method consistent with the number of samples collected, and distribution pattern of

the parameter. Examples of appropriate statistical methods and performance standards are outlined in the EPA document Criteria For Municipal Solid Waste Landfills, Subpart E section 258.53 paragraphs (g) & (h).

8.2 Immiscible Layers

Immiscible layers may be either light nonaqueous phase liquids (LNAPLs) or dense nonaqueous phase liquids (DNAPLs). LNAPL layers must be sampled before a well is purged. To determine the presence of an immiscible layer, an interface probe should be used to measure the first fluid level in a well. Once this has been recorded, it should be lowered until the immiscible water interface is encountered. The depth interval, or thickness, of a floating immiscible layer can then be established.

8.3 Purging

Water which has resided in a well casing for an extended period of time has the opportunity to exchange gases with the atmosphere and to interact with the well casing. Water standing in the columns inside the well casing must, therefore, be purged prior to sampling so that a representative sample can be obtained. To adequately purge a well, monitor the pH, temperature, and conductance of the water during the purging process, and assume purging is complete when these measurements stabilize. While 3 to 4 purge volumes are common industry practice, it is recommended that the appropriate number be determined on a site specific basis according to the number required to reach equilibrium.

Purging should be accomplished by removing groundwater from the well at low flow rates using a pump. Because they can operate at variable speeds, pumps such as the submersible and bladder variety are considered particularly useful for purging stagnant water from a well. The use of bailers should generally be avoided as the 'plunger' effect of their use can result in the continual development or overdevelopment of the well. A description of six different kinds of pumps is presented in Appendix 4.

Wells should be purged at rates lower than those used to develop the well. A low purge rate will reduce the possibility of stripping VOCs from the water and reduce the likelihood of mobilizing colloids in the subsurface that are immobile under natural flow conditions. For further reference, refer to the designation guide ASTM D4448-85a.

If contaminants are suspected in the groundwater prior to purging, then appropriate disposal measures should be performed. The purged groundwater should be collected and tested and disposed of in accordance with established sanitary/stormwater sewer use criteria and other applicable regulatory requirements.

8.4 Sample Extraction

The rate at which a well is sampled should not exceed the rate at which the well was purged. Low sampling rates, approximately 0.1 L/min, are suggested. Pumps should be operated at rates less than 0.1 L/min when collecting samples for volatile organic compound analysis.

Sample withdrawal methods include the use of pumps, compressed air, syringe sampler, and bailers. The selection of the sampling method must be based on the parameters that are to be monitored, the depth from which the sample is collected, and the diameter of the well (Piteau '90). The primary consideration is to obtain a representative sample of the groundwater body by guarding against mixing the sample with stagnant water in the well casing. This is avoided through adequate purging prior to collecting the sample. Refer to Appendix 4 for a description of a number of different sampling devices that are available to extract water from a variety of monitoring well diameters.

8.4.1 Organic Contaminant Sampling

Groundwater samples collected for analyzing organic constituents should not be field-filtered prior to laboratory analysis. The recommended container for collection is a solvent rinsed, amber coloured glass with an aluminum foil or Teflon liner cap. An emerging technology that promises to provide an alternative to collecting and shipping large samples of water involves a technique called solid phase extraction (SPE). In this technique, a volume of water is passed through a solid phase that adsorbs the organic contaminants. The adsorbent material is sent to the laboratory for extraction and analysis. Consult the manufacturer's literature for further information on this technique. For additional QA details refer to Appendix 5.

8.4.1.1 Volatile Organic Compounds

Volatile organic compounds (VOCs) must be sampled in a manner which does not cause agitation of the sample or exposure of the sample to air. Pumps which induce suction pressure, such as peristaltic pumps, or which have lift devices, may aerate the sample and are not recommended for sampling VOCs. Positive displacement bladder pumps or bailers constructed entirely of fluorocarbon resin or stainless steel are preferred. VOCs should be the first sample that is collected following the purging process (EPA, Sept '88).

During sampling, the pumping rate should be kept to a rate of less than 0.1 L/min. Samples should be placed directly in glass bottles with no air space left and capped with a Teflon septum cap.

8.4.1.2 Extractable Organic Compounds

Samples for extractable organics should be collected after the VOCS samples. Glass or Teflon bottles with Teflon lined caps should be used as sample containers (Piteau, '90); alternatively, solid phase extraction (SPE) may be performed on-site.

8.4.2 Inorganic Contaminant Sampling

8.4.2.1 Specific Conductivity

Specific conductance and temperature should be measured in the field using portable equipment. Since many effluents, and in particular landfill leachate, have substantially higher temperature and specific conductance than natural groundwater, the presence of such a leachate can often be detected using a conductance - temperature probe. Specific conductance can be measured quickly and easily and is useful for estimating the total amount of inorganic dissolved solids.

Specific conductance and pH should ideally be measured both in the field and in the laboratory; differences may indicate that sample degradation has occurred during shipping and storage. For reliable comparisons, it is mandatory that adequate calibration of field instrumentation is maintained. Additional parameters that should be measured in the field include redox potential and dissolved oxygen.

8.4.2.2 Metal Compounds

Groundwater samples collected to monitor total metal contaminants should be collected in an acid-cleaned, plastic container and preserved in an acid solution prior to analysis. Groundwater samples collected for analyzing dissolved metal contaminants should be field-filtered under pressure, collected in an acid-cleaned plastic container, and preserved in an acid solution prior to analysis.

Refer to Appendix 5 for appropriate preservation and collection techniques. Note that samples must not be decanted as an alternative to filtering.

Note: To avoid contamination, the collection containers for groundwater samples to be analyzed for inorganic contaminants should be pre-cleaned and certified by the supplier or by adequate batch testing. Containers should not be rinsed with sample prior to sample collection as surface concentration effects may occur. For appropriate container and rinsing agents refer to Appendix 5.

8.5 Sample Preservation

To assist in maintaining the natural chemistry of the samples, it is necessary to preserve the sample. Methods of sample preservation are relatively limited and are intended to reduce the effects of chemical reactions, the effects of sorption and to arrest biological actions. Preservation methods are generally limited to pH control, refrigeration, and protection from light. Selected parameters or groups of parameters (e.g., metals) may be preserved by addition of a reagent (e.g., acid) that stabilizes their concentration but may preclude the analysis of that sample for other parameters.

Glass, stainless steel, Teflon, or plastic (polyethylene and polypropylene) are the types of containers acceptable for most kinds of sample collection. There are some exceptions to this general rule; for example, plastic is not acceptable for organics and stainless steel is not acceptable for metals. Containers should be kept full until samples are analyzed to maintain anaerobic conditions. The sample container material should be non-reactive with the sample and especially with the particular analytical parameter to be tested. Sample containers used to transport samples to the lab must undergo pre-treatment procedures. Pre-treated containers may be purchased commercially; however, pre-treatment must be repeated if they are re-used. For appropriate sample containers and preservation methods, refer to Appendix 5.

Samples should be placed in bottles immediately upon collection and, where preservation of the sample is required, it should be carried out immediately. Handling of the sample and contact with the atmosphere should be kept to a minimum. The samples should be properly packaged so as to prevent breakage and should generally be kept at 4°C plus/minus 2°C until analyzed by the laboratory. It is recommended that the sampler consult with the laboratory to discuss sampling protocols and sample treatment options prior to sample collection.

9. Sources of Further Information

- Aller, Linda et al. Handbook of Suggested Practices for the Design and Installation of Ground-Water Monitoring Wells. Appendix B, pg 324-366. National Water Well Association, 1989.
- American Standards for Testing and Materials. Annual Book of ASTM Standards. Volume 11.01, Water and Environmental Technology. Designation: D3370-82. Philadelphia, PA. 1991.
- American Standards for Testing and Materials. Annual Book of ASTM Standards. Volume 11.04, Water and Environmental Technology. Designation: D5088-90. Philadelphia, PA. 1991.
- American Standards for Testing and Materials. Annual Book of ASTM Standards. Volume 11.04, Water and Environmental Technology. Designation: D4448-85a. Philadelphia, PA. 1992.
- Barcelona, M.J. et al, September 1985. Practical Guide for Ground-Water Sampling. EPA/600/2-85/104, US EPA, Roberts S. Kerr Environmental Research Laboratory, Ada, Oklahoma.
- Environmental Protection Agency. Solid Waste Disposal Facility Criteria - Technical Manual. EPA530-R-93-017 US EPA, November 1993.
- Gartner Lee Limited. Leachate Assessment Field Manual. Prepared for Ministry of Environment, Lands and Parks. Skeena Region. February 1993.
- Henry, Glynn and Prasad, Durga. Anaerobic Treatment of Leachate. Paper presented at a seminar on leachate treatment and disposal, sponsored by the Pollution Control Association of Ontario and the Ontario Ministry of Environment. Toronto, Ontario. 1991.
- Kent, Robert and Payne, Katherine. "Sampling Groundwater Monitoring Wells: Special Quality Assurance and Quality Control Considerations". Principles of Environmental Sampling. Chapter 15. Lawrence Keith, Editor. 1988.
- Everett, Lorne G., Ph. D. Groundwater Monitoring. Guidelines and Methodology for Developing and Implementing a Groundwater Quality Monitoring Program. Genium Publishing Corporation. 1984.
- Lu, James C.S., Eichenberger, Bert, and Sterns, Robert J. Leachate from Municipal Landfills: Production and Management. Noyes Publications. 1985.
- Nagpal, N.K. and Pommen, L.W. Approved and Working Criteria for Water Quality. B.C. Environment Water Quality Branch. November 1993.

- National Association of Waste Disposal Contractors. NAWDC: Creating a Better Environment. NAWDC Codes of Practice for Landfill. August 1989.
- Ontario Ministry of Environment and Energy. Guidelines for the Establishment, Operation, Management, Maintenance and Closure of Landfilling Sites in Ontario.
- Ontario Ministry of Environment and Energy. Guideline for Assessing Methane Hazards from Landfill Sites. November 1987.
- Piteau Associates Engineering Limited. Groundwater Quality Monitoring Manual. Prepared for BC Ministry of Environment, Environmental Protection Division. March 1990.
- Province of British Columbia. Approved and Working Criteria for Water Quality. Ministry of Environment, Lands and Parks. Environmental Protection Department, Water Quality Branch. 1995.
- Province of British Columbia. Criteria for Managing Contaminated Sites in British Columbia. Ministry of Environment, Lands and Parks. Environmental Protection Department, Water Quality Branch. July 1995.
- Province of British Columbia. Landfill Criteria for Municipal Solid Waste. Ministry of Environment, Lands, and Parks. Environmental Protection Division, Municipal Waste Reduction Branch. 1993.
- Sabel, G. and Clark, T. Procedures for Ground Water Monitoring. Minnesota Pollution Control Agency Guidelines. April 1985.
- Solid Waste Association of North America. Manager of Landfill Operations Training Course. Course manual. Publication # MSW-D 2360 GMISC 0005. Silver Spring, Maryland. Revised June 1991.
- State of Washington. Criteria for Municipal Solid Waste Landfills. Washington Administration Code. Chapter 173-351. OTS Version.
- State of Washington. Minimum Functional Standards for Solid Waste Handling. Chapter 173-304 WAC.
- United States. Federal Register. Vol. 56, No.104. May, 1991. Proposed Rules. Environmental Protection Agency.
- United States. Procedures Manual for Ground Water Monitoring at Solid Waste Disposal Facilities. Environmental Protection Agency. 1977.

United States. RCRA Ground-Water Monitoring Technical Enforcement Guidance Document. Environmental Protection Agency. NWWA/EPA Series. Printed by NWWA. Dublin, Ohio. September 1986.

United States. Solid Waste Disposal Facility Criteria. Environmental Protection Agency. Technical Manual. November 1993.

Waste Age. University of Wisconsin/Waste Age. Landfill Course. January 1986.

10. Revision History

- October 10, 2013: This section republished without change. Notes added to Appendix 5. Sample Container and Preservation Criteria table updated.
- February 28, 2001: This section republished without change. Bottle types adjusted for mercury in Appendix 5.
- November 1996: Initial publication.

Appendix 1 Recommendations for Screen and Casing Materials in Sampling Applications

(in decreasing order of preference)

Material	Applications	Other Considerations	Approximate Cost (Relative to PVC)*
Fluorinated Ethylene Propylene (FEP)	Recommended for most monitoring situations where corrosive environments are anticipated. Also offers good chemical resistance to volatile organics.	Lower strength than steel and iron. Not available in British Columbia.	> 20 x
Polytetra floethylene (PTFE) or Teflon (R)	Recommended for most monitoring situations with detailed organic analytical needs, particularly for aggressive, organic leachate impacted hydrogeologic conditions. Virtually an ideal material for corrosive situations where inorganic contaminants are of interest.	Low strength, not readily available in British Columbia (- 10 days for delivery).	21 x
Kynar	Strong material that is resistant to most chemicals and solvents.	Poor chemical resistance to ketones and acetone. Not commonly available.	
Fibreglass	Historically, fibreglass has not been used for monitoring wells due to potential leaching of epoxy resins. Recent advances in fibreglass technology have created a material that is equivalent to or more inert than Teflon, but is also very strong.	High strength, not readily available in British Columbia. Not available as 50 mm casing.	2 to 5 x
Stainless Steel 316 (flush threaded)	Recommended for most monitoring situations with detailed organic analytical needs, particularly for aggressive, organic leachate impacted hydrogeologic conditions.	High strength, reasonable availability. May be source of Cr, Fe and Ni in low pH environments.	10 x
Stainless steel 304 (flush threaded)	May be prone to slow pitting corrosion in contact with acidic, high TDS aqueous solutions. Corrosion products limited mainly to Fe and possibly Cr and Ni.	High strength, good availability. May be source of Cr, Fe and Ni in low pH environments.	7.5 x

Ground Pollution Monitoring

<p>PVC (flush threaded or other noncemented connections)</p>	<p>Recommended for monitoring situations where inorganic contaminants are of interest and it is known that aggressive organic leachate mixtures will not be contacted. Cemented installations have caused documented interferences.</p> <p>The potential for interaction and interferences from PVC well casing in contact with aggressive aqueous organic mixtures is difficult to predict. PVC is not recommended where ppb or corrosive concentrations of organic contaminants are expected.</p>	<p>PVC can be used as casing with stainless steel screens for composite well. Moderate strength, good availability.</p> <p>Deteriorates when in contact with ketones, esters and aromatic hydrocarbons.</p>	<p>1 x</p>
--	---	---	------------

Materials below this line are not recommended as they cost more than PVC while rated as inferior.			
<p>Acrylonitrile Butadiene Styrene (ABS)</p>	<p>Not commonly used for groundwater monitoring.</p>	<p>Lower strength than steel and iron. Not readily available other than in domestic plumbing format which is not generally suitable for piezometer applications.</p>	<p>2 x</p>
<p>Polypropylene</p>	<p>Resistance to mineral acids and moderate resistance to alkalis, alcohols, ketones and esters make polypropylene a suitable material for many applications. It deteriorates when in contact with oxidizing acids, aliphatic and aromatic hydrocarbons.</p>	<p>Low strength, not readily available in British Columbia.</p>	
<p>Polyethylene: High Density</p>	<p>Polyethylene is less reactive than PVC but more reactive than PTFE.</p>	<p>Low strength. Not commonly available in format other than flexible water line. Not threadable.</p>	<p>1 x</p>
<p>Low Carbon Steel</p>	<p>May be superior to PVC for exposures to aggressive aqueous organic mixtures. These materials must be very carefully cleaned to remove oily manufacturing residues.</p>	<p>Prone to rusting.</p>	

Ground Pollution Monitoring

Galvanized Steel	Corrosion is likely in acidic, high TDS environments, particularly when sulfides are present. Products of corrosion are mainly Fe and Mn, except for galvanized steel which may release Zn and Cd.	High strength, good availability. Prone to rusting.	1.25 to 3 x
Carbon Steel	Weathered steel surfaces present very active absorption sites for trace organic and inorganic chemical species.	Prone to rusting.	

(Piteau March 1990. Table 5.2)

* Source of availability and relative cost: CPI Equipment, the largest supplier of drilling equipment in B.C.

Appendix 2 Drilling Methods Matrix

	DRILLING METHODS							
	Air Rotary	Cable Tool	Hollow Stem Auger	Sonic Drilling	Becket Hammer	Mud Rotary	Bucket Auger	Backhoe Excavation
Applicable Geology								
Unconsolidated Overburden	X	X	X	X	X	X	X	X
Fine Grained Sediments	X	X	X	X	X	X	X	X
Soft Rock	X	X				X		
Cohesive Sediments	X	X		X		X		
Unconsolidated Sediments	X	X	X	X	X	X	X	X
Bedrock	X	X				X		
Surficial Sediments	X	X	X	X	X	X	X	X
Soft to Mod. Dense Sediments	X	X	X	X	X	X		
Maximum Depth (m)	>300	>200	50		50	>300	10	8
Avg. Hole Diameter (mm)	150	150	125		150	150	800	1,000

(After Piteau, 1990)

Appendix 3 Typical Monitoring Well Design

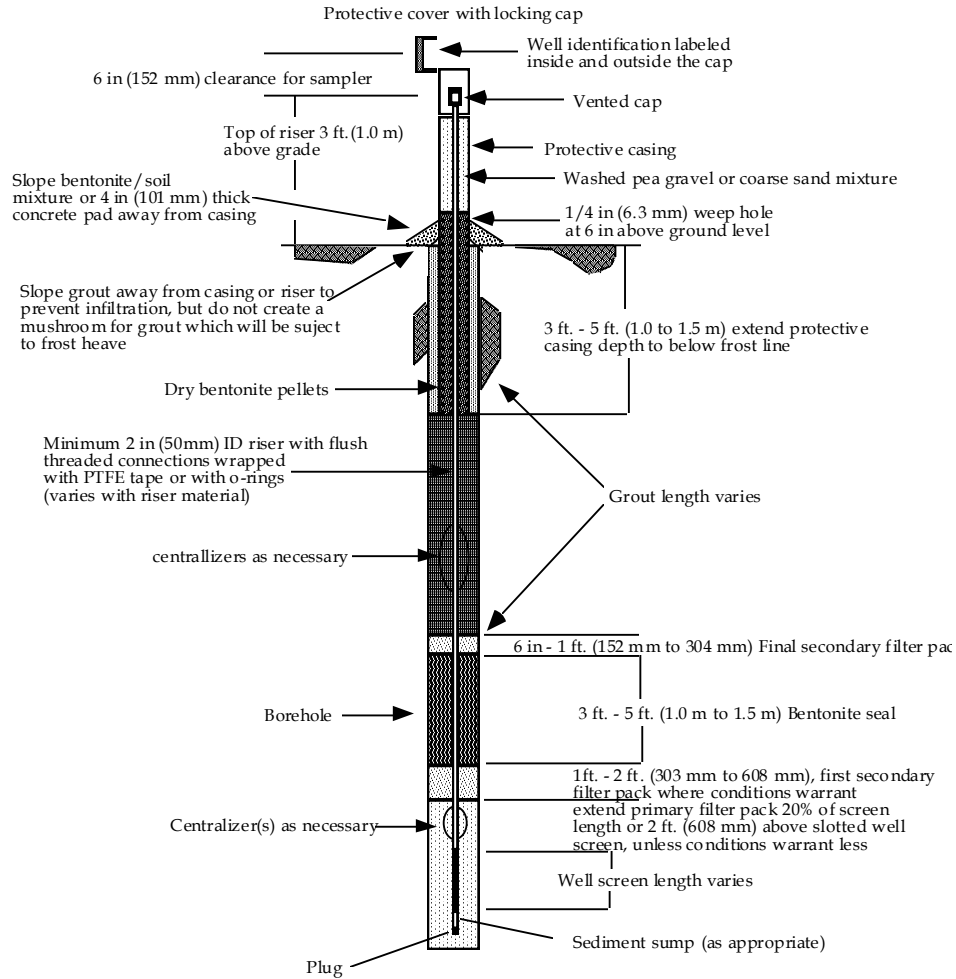

* Reprint with permission, from the Annual Book of ASTM Standards, copyright American Society for Testing and Materials, 1916 Race Street, Philadelphia, PA 19103. Figure redrawn for legibility.

Appendix 4 Sampling Equipment

Sampling Devices	How the Sampling Device Operates	Pumping Rates	Characteristics	Disadvantages
Air Lift Pump	An air lift pump collects a water sample by bubbling a gas at depth in the well or tube.	Pumping rates depend on the size of the pump being used and how many pumps are used for each well.	Air lift sampling can be useful in monitoring wells that need to be pumped only at periodic intervals.	Air lift methods result in considerable sample agitation and mixing in the well.
Submersible Pump	Water is transported to the surface by centrifugal action through an access tube.	Vary from 26.5-53.0 Lpm depending upon the depth of the pump.	A submersible pump provides higher extraction rates than most other methods.	Considerable sample agitation and the potential introduction of trace metals into the sample from pump materials results.
Suction Lift Pump	Suction lift can be categorized as direct line, centrifugal and peristaltic.	Vary from 19-151 Lpm for direct line method. Approximately 3.7 Lpm for peristaltic pump method.	Suction lift approaches offer a simple retrieval method for shallow monitoring.	Degassing and agitation occur as a result of suction lift.
Bladder Pump	Water enters the flexible membrane through the lower check valve; compressed gas is injected into the cavity between the stainless steel housing and the bladder.	The 4.4 cm pump is capable of providing samples (Approx. 2.6 - 5.6 Lpm) from depths in excess of 76m.	Bladder pumps prevent contact between the gas and water sample and can be fabricated entirely of Teflon and stainless steel.	The large gas volumes required, especially at depth, potential bladder rupture, and the difficulty in disassembling the unit for thorough cleaning. Piezometers must be developed with no fines inside casing.
Gas Displacement Pump	A column of water under linear flow conditions is forced to the surface without extensive mixing of the pressurized gas and water.	Flow rates of about 2.8 Lpm at 36.5m are possible with a standard 3.7 cm inner diameter by 4.57 cm long pump.	Gas displacement pumps provide a reliable means for obtaining a highly representative ground water sample.	Possibility of gas water interface, a degree of mixing, and sample degassing can occur during transport.
Gas Piston Pump	A double piston pump utilizes compressed air to force a piston to raise the sample to the surface.	Pumping rates of 0.5 Lpm have been reported from 30.5 m; sampling depth of 152 m are possible.	The gas piston pump provides continuous sample withdrawal at depths greater than is possible with most other approaches.	Contribution of trace elements from the stainless steel and brass is a potential problem.
Packer Pump	The hydraulic activated packers are wedged against the casing wall or screen, the sampling unit collects water samples only from the isolated portion of the well.	Vertical movement of water outside the well casing during sampling is possible with packer pumps but depends upon the pumping rate and subsequent disturbance.	A packer assembly allows the isolation of sampling points within a well.	Deterioration of the expandable material will occur with time thereby increasing the possibility of undesirable organic contaminants entering the water sample.
Inertial Lift Pump	The operating principle of the pump is based on the inertia of a column of water contained within a riser tubing.	Pumping rates of between 0.05 to 10.0 Lpm have been recorded.	The inertial pump is inexpensive and offers multiple uses for ground water monitoring wells.	The tubing coils, though reasonably lightweight, are stiff and may be awkward to transfer from well to well.

* Text extracted from Appendix D, Piteau (1990), from R.D. Morrison (1983).

Appendix 5 Sample Container and Preservation Criteria

TYPE OF ANALYSIS ^(1, 2)	STORAGE MAXIMUM TEMP ⁽³⁾	CONTAINER TYPE	PRESERVATION	HOLD TIME ⁽⁴⁾ (days)
WATER - BACTERIOLOGY PARAMETERS				
Coliforms, Total, Fecal and E. coli	<8°C, do not freeze	Ster P or G	Na ₂ S ₂ O ₃	30 hours ⁽⁵⁾
Cryptosporidium, Giardia	<8°C, do not freeze	Ster P or G	Na ₂ S ₂ O ₃	96 hours
Enterococcus	<8°C, do not freeze	Ster P or G	Na ₂ S ₂ O ₃	30 hours ⁽⁵⁾
Heterotrophic Plate Count	<8°C, do not freeze	Ster P or G	Na ₂ S ₂ O ₃	24 hours
TOXICITY				
Daphnia, Chronic 21 day/ Chronic EC25	4±2°C	P, G (non-toxic)	collect with no headspace	5
Daphnia, LC50 / LT50	4±2°C	P, G (non-toxic)	collect with no headspace	5
Microtox	4±2°C	P, G (non-toxic)	collect with no headspace	3
Trout, LC50	4±2°C	P, G (non-toxic)	collect with no headspace	5
Trout, LT50	4±2°C	P, G (non-toxic)	collect with no headspace	5
PHYSICAL & AGGREGATE PROPERTIES				
Acidity	≤6°C	P, G	none	14
Alkalinity	≤6°C	P, G	none	14
Colour	≤6°C	P, G	none	3
Conductivity	≤6°C	P, G	none	28
pH	≤6°C	P, G	none	15 minutes
Solids (Total, TSS, TDS, Fixed, Volatile, etc.)	6°C	P, G	none	7
Turbidity	≤6°C	P, G	store in the dark	3

Ground Pollution Monitoring

WATER - INORGANIC ANALYSIS

Bromide	no req.	P, G	none	28
Chloride	no req.	P, G	none	28
Chlorate, Bromate	≤6°C	P, G	50 mg/L EDA	28
Chlorine, Total Residual (Free Chlorine)	none	P, G	none	15 minutes
Chlorite	≤6°C	P, A, G	50 mg/L EDA	14
Cyanide, SAD and/or WAD	≤6°C	P, G	field NaOH, store in dark	14
Dissolved Oxygen (Winkler Method)	≤6°C	G, BOD bottle	none Winkler kit, store in dark	1 8 hours
Fluoride	no req.	P	none	28
Nitrogen, Nitrate + Nitrite	≤6°C	P, G	H ₂ SO ₄ none (BC MOE)	28 3
Nitrogen, Ammonia	≤6°C	P, G	H ₂ SO ₄ none (BC MOE)	28 3
Nitrogen, Nitrate	≤6°C, do not freeze	P, G	none	3
Nitrogen, Nitrite	≤6°C, do not freeze	P, G	none	3
Nitrogen, Total Kjeldahl	≤6°C	P, G	H ₂ SO ₄ none (BC MOE)	28 3
Nitrogen, Total, Persulfate Method	≤6°C	P, G	H ₂ SO ₄ none (BC MOE)	28 3
Nitrogen, Total, Combustion Method	≤6°C	P, G	HCl none(BCMOE)	28 3
Phosphorus, Dissolved (Orthophosphate)	≤6°C	P, G	filter (field or lab)	3
Phosphorus, Total Reactive (Orthophosphate)	≤6°C	P, G	none	3
Phosphorus, Total Dissolved	≤6°C	P, G	filter, H ₂ SO ₄ none	28 3

Ground Pollution Monitoring

Phosphorus, Total	≤6°C	P, G	H ₂ SO ₄ none (BC MOE)	28 3
Silica, Reactive	≤6°C, do not freeze	P	none	28
Sulfate	≤6°C	P, G	none	28
Sulfide	≤6°C	P or G	ZnAc/NaOH to pH >9	7
METALS				
Hexavalent Chromium	≤6°C	P, G	1 ml 50% NaOH per 125 ml none	30 1
Metals, Total	≤6°C	P, G	HNO ₃ ⁽⁷⁾	180
Metals, Dissolved	no req.	P, G	field filter 0.45 um + HNO ₃ ⁽⁷⁾	180
Mercury, Total	no req.	G, PTFE	HCL or BrCL ⁽⁸⁾	28
Mercury, dissolved	no req.	G, PTFE	field filter 0.45 um + HCL or BrCL ⁽⁷⁾	28
AGGREGATE ORGANIC ANALYSIS				
AOX (Absorbable Organic Halides)	≤6°C	A, G	HNO ₃ , store in dark sodium sulfite if chlorinated, collect with no headspace	14
Biochemical Oxygen Demand (BOD)	≤6°C, do not freeze	P, G	none	3
Carbonaceous Biochemical Oxygen Demand (CBOD)	≤6°C, do not freeze	P, G	none	3
Carbon, Dissolved Organic	≤6°C	P, G	filter, H ₂ SO ₄ or HCl none (BC MOE)	28 3
Carbon, Dissolved Inorganic	≤6°C	P, G	field filter	14
Carbon, Total Organic	≤6°C	P, G	H ₂ SO ₄ or HCl	28
Carbon, Total Inorganic	≤6°C	P, G	none	14
Chemical Oxygen Demand (COD)	≤6°C	P, G	H ₂ SO ₄ (field or lab) none (BC MOE)	28 3

Ground Pollution Monitoring

Chlorophyll <i>a</i>	Filters: freeze ≤6°C	Filter P, A, G	field filter, store in dark unfiltered, store in dark	Filters: 28 2
Phaeophytin	Filters: freeze	Filter	field filter, store in dark	Filters: 28
Surfactants (Methylene Blue Active Substances)	≤6°C	P, G	none	3
Total Phenols (4AAP)	≤6°C	P, G	H ₂ SO ₄	28
EXTRACTABLE HYDROCARBONS				
Extractable Hydrocarbons	≤6°C	A, G	HCl, H ₂ SO ₄ or Sodium Bisulfate none	14/40 7/40
Oil & Grease / Mineral Oil and Grease	≤6°C	A, G	HCL OR H ₂ SO ₄	28
Waste Oil Content	≤6°C	A, G	none	28
INDIVIDUAL ORGANIC COMPOUNDS				
Carbamate Pesticides	≤6°C	A, G	Potassium Dihydrogen Citrate(solid), ~pH 3.8, 9.2-9.5 g/L, + 100 mg/L Na ₂ S ₂ O ₃ if chlorinated	28
			ChlorAC buffer, ~pH 3, 1.8mL/60 mL sample+ 100 mg/L Na ₂ S ₂ O ₃ if chlorinated	28
Chlorinated and Non-chlorinated Phenolics	≤6°C	A, G	0.5g Ascorbic Acid / L + H ₂ SO ₄ or Sodium Bisulfate none	14/40 7/40
Dioxins / Furans	≤6°C	G, A	none	unlimited
Glyphosate / AMPA	≤6°C	A, G or Poly-Propylene	100 mg/L Na ₂ S ₂ O ₃ if chlorinated	14

Ground Pollution Monitoring

Glycols	≤6°C	G	HCL, H ₂ SO ₄ or Sodium Bisulfate none	14/40 7/40
Halogenated Hydrocarbons (Semi-Volatile)	≤6°C	A, G	100 mg/L Na ₂ S ₂ O ₃ if chlorinated	7/40
Herbicides, Acid Extractable	≤6°C	A, G	HCL (optional), store in dark, 50 mg/L Na ₂ S ₂ O ₃ if chlorinated	14/21
Paraquat / Diquat	≤6°C	A, G	100 mg/L Na ₂ S ₂ O ₃ if chlorinated	7/21
Pesticides (NP, OP, OC)	≤6°C	A, G	none	7/40
Polychlorinated Biphenyls (PCBs)	≤6°C	A, G	none	unlimited
Polycyclic Aromatic Hydrocarbons (PAHs)	≤6°C	A, G	HCL, H ₂ SO ₄ or Sodium Bisulfate none	14/40 7/40
Resin Acids, Fatty Acids	≤6°C	A, G	(0.5g Ascorbic Acid + 0.4g NaOH) / L none	14/40 7/40
Volatiles Organic Compounds (Trihalomethanes)	≤6°C	43ml G VOC Vials (2-3)	3 mg Na ₂ S ₂ O ₃ (see BC Lab Manual method for more details)	14
Volatiles Organic Compounds (VOC, BTEX, VH)	≤6°C	43ml G VOC Vials (2-3)	200 mg NaHSO ₄ , or 3 mg Na ₂ S ₂ O ₃ Id chlorinated (see BC lab Manual method for other options and details)	14
SOIL & SEDIMENT				
INORGANIC				
Bromide / Chloride and Fluoride	no req.	P, G	none	unlimited
Cyanide (WAD / SAD)	≤6°C	P, G	store in dark, field moist	14
Hexavalent Chromium	≤6°C	P, G	store field moist	30/7
Metals, Total	no req.	P, G	none	180

Ground Pollution Monitoring

Mercury, Total	no req.	P, G	none	none 28
Moisture	≤6°C	P, G	none	14
pH	no req.	P, G	none	365
Sulfide	≤6°C	P, G	store field moist	7
TCLP - Mercury	no req.	P, G	none	28/28
TCLP - Metals	no req.	P, G	none	180/180
ORGANICS				
Carbon (TC, TOC)	≤6°C	P, G	none	28
	no req.	P, G	dried stage	unlimited
Chlorinated and Non-chlorinated phenolics	≤6°C	G	none	14/40
Dioxins / Furans	≤6°C	G	none	unlimited
Extractable Hydrocarbons (LEPH, HEPH, EPH)	≤6°C	G	none	14/40
Glycols	≤6°C	G	none	14/40
Herbicides, Acid Extractable	≤6°C	G	none	14/40
Oil and Grease/Mineral Oil and Grease/Waste Oil Content	≤6°C	G	none	28
Pesticides (NP, OP, OC)	≤6°C	G	none	14/40
Polychlorinated Biphenyls (PCBs)	≤6°C	G	none	unlimited
Polycyclic Aromatic Hydrocarbons (PAHs)	≤6°C	G	none	14/40
Resin Acids, Fatty Acids	≤6°C	G	none	14/40
TCLP - Volatile Organic Compounds	≤6°C	G	none	14/14
TCLP - Semi-Volatile Organic Compounds	≤6°C	G	none	14/40
Volatile Organic Compounds (VOC, BTEX, VH, THM)	≤6°C	G	none	7 (6)/40

LEGEND

P = plastic	Ster = sterilized	T = tissue cup
G = glass	Solv = solvent cleaned	B = baked
A = amber	Fc = foil-lined cap	P&T = purge and trap vials
W = wide mouth	R = acid rinsed	no req = no requirement

- ¹ A Director or an Environmental Management Act permit may specify alternate requirements.
- ² Refer to applicable BC Environmental Laboratory Manual methods for additional detail. Where differences exist between Lab Manual methods and this table, this table takes precedence.
- ³ Storage temperature applies to storage at the laboratory. For all tests where refrigeration at $\leq 6^{\circ}\text{C}$ is required at the laboratory, samples should be packed with ice or cold packs to maintain a temperature of $\leq 10^{\circ}\text{C}$ during transport to the laboratory. The storage of $\leq 8^{\circ}\text{C}$ for microbiological samples applies during storage at the laboratory and during transport to the laboratory. To prevent breakage, water samples stored in glass should not be frozen. Except where indicated by "do not freeze", test results need not be qualified for frozen samples.
- ⁴ Hold Times: Single values refer to hold time from sampling to analysis. Where 2 values are given, the first is hold time from sampling to extraction, and the second is hold time from extraction to analysis.
- ⁵ Samples received from remote locations more than 48 hours after collection must not be tested.
- ⁶ Methanol extraction or freezing must be initiated within 48 hours of arrival at lab, to a maximum of 7 days from sample collection. Alternatively, samples may be frozen in the field if extracted within 14 days of sampling, or may be methanol extracted in the field.
- ⁷ Samples collected for dissolved metals analysis must be filtered in the field as soon as possible after collection (preferably within 15 minutes). This is particularly important for groundwaters where exposure to atmospheric conditions can trigger redox reactions that cause certain metals to precipitate (particularly iron). If precipitation of iron oxides occurs, many other heavy metals may precipitate or co-precipitate, potentially causing substantially low bias for many metallic elements. In extreme cases, some elements may be 100% removed from solution due to precipitation or co-precipitation caused by delay of filtration. Samples collected for dissolved metals analysis must be field filtered and then preserved with HNO_3 .
- If not field-preserved, water samples collected for total metals analysis must be acidified at the lab in their original containers by addition of HNO_3 (within 14 days of sampling), then equilibrated at least 16 hours prior to sub-sampling or analysis (otherwise, qualify as "received unpreserved"). Not applicable to mercury.
- ⁸ Use only glass or PTFE containers to collect water samples for total or dissolved mercury. For total mercury, field-preserve with HCl or BrCl . Adding BrCl to original sample container at the laboratory within 28 days of sampling is an acceptable alternative for total mercury if samples are oxidized for 24 hours prior to sub-sampling or analysis. Samples collected for dissolved mercury analysis must be field filtered and then preserved with HCl or BrCl although BrCl is not recommended for use in the field for safety reasons.

Appendix 6 Generalized Flow Diagram of Groundwater Sampling Steps

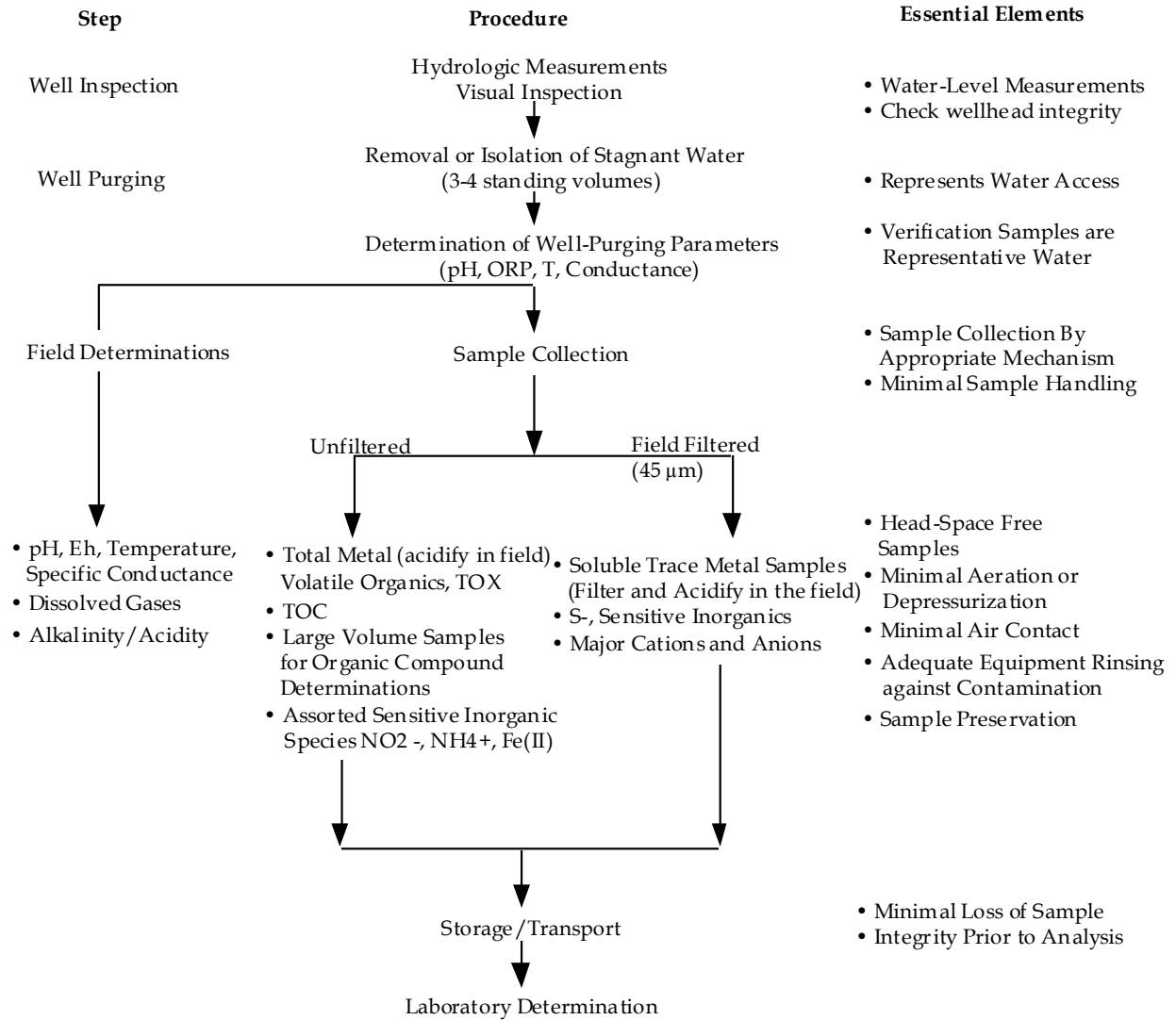

Filtration should be accomplished preferably with in-line filters and pump pressure or by N₂ pressure methods. Samples for dissolved gases or volatile organics should not be filtered. In instances where well development procedures do not allow for turbidity-free samples and may bias analytical results, split samples should be spiked with standards before filtration.

Both spiked samples and regular samples should be analyzed to determine recoveries from both types of handling. Assorted Field Blanks and Standards: as needed for good QA/QC.

(Modified Piteau 1990, Fig. 5.7)

EFFLUENT FLOW MEASUREMENT

©Her Majesty the Queen in
Right of the Province of British Columbia
2013
All Rights Reserved

NOTE: The section on Effluent Flow Measurement was prepared
for the Ministry by NovaTec Consultants Ltd.

Table of Contents

1. INTRODUCTION.....	320
2. OPEN CHANNEL FLOW	320
2.1 PRIMARY DEVICES (WEIRS AND FLUMES)	320
2.1.1 Weirs.....	322
2.1.1.2 Flow Conditions.....	322
2.1.1.3 Application.....	324
2.1.1.4 Common Weir Types.....	324
2.1.2 Flumes	332
2.1.2.1 Definition and Description.....	332
2.1.2.2 Flow Conditions.....	332
2.1.2.3 Application.....	333
2.1.2.4 Common Flume Types	333
2.1.3 Installation and Design of Primary Flow Measurement Devices	340
2.1.3.1 Weir Installation.....	340
2.1.3.2 Flume Installation	342
2.1.4 Calibration of Primary Flow Measurement Devices	342
2.1.4.1 Volumetric Method	342
2.1.4.2 Dilution (dye) Method	343
2.1.4.3 Point Method	343
2.1.5 Maintenance of Primary Flow Measurement Devices	343
2.2. SECONDARY MEASURING DEVICES (FLOW METERS).....	343
2.2.1 Floats.....	343
2.2.2 Electrical (Capacitance Probe).....	344
2.2.3 Ultrasonic Level Sensors.....	346
2.2.4 Bubblers.....	346
2.3 SELECTION CRITERIA FOR SECONDARY MEASURING DEVICES.....	347
2.4 INSTALLATION OF SECONDARY FLOW MEASUREMENT DEVICES..	347
2.5 CALIBRATION OF SECONDARY FLOW MEASUREMENT DEVICES	348
2.6 MAINTENANCE OF SECONDARY FLOW MEASUREMENT DEVICES...	348

3.	CLOSED CHANNEL FLOW MEASUREMENT	349
3.1	ORIFICE FLOW METER.....	349
3.2	VENTURI FLOW METER	350
3.3	ELECTROMAGNETIC FLOW METER	353
3.4	DOPPLER FLOW METER.....	354
3.5	PRESSURE TRANSDUCERS	354
3.5.1.	Selection of Pressure Transducers.....	355
3.6	Area Velocity.....	355
4.	FLOW RECORDERS.....	356
4.1	FLOW TRANSMITTERS.....	357
4.2	CHART RECORDERS AND DATA LOGGERS	357
4.2.1	Charts vs Data Loggers.....	358
4.2.2	Selection Criteria of Recorders and Data Loggers.....	358
5.	SOURCES OF FURTHER INFORMATION	359
6.	REVISION HISTORY	359
	APPENDIX 1 EFFLUENT FLOW MEASUREMENT CHECKLIST	360

1. Introduction

The accurate measurement of wastewater flows is critical to the successful performance of a wastewater treatment plant. Flow measurement is of interest from an operations perspective at various stages of the treatment process including process flow streams within the plant, and effluent leaving the plant. The primary factor in the selection of the measurement device is whether the wastewater or effluent is being transported under open channel (e.g. open trough or partially filled pipes) or under full pipe conditions.

2. Open Channel Flow

Open channel flow is defined as the flow in a conduit, in which the upper surface of the liquid is in contact with the atmosphere (free surface), such as in the case of an open trough, or a partially filled pipe (see Figure 1). Open channel flow measurement devices are traditionally the most common method of flow measurement in wastewater treatment plants but as the use of metering increases, this is changing. The flow in an open channel is measured using a combination of a primary device (a structure restricting flow and causing the liquid level to vary proportionately with flow), and a secondary device (which measures the variation in liquid level caused by the primary device) (Kirkpatrick and Shelley [1]).

2.1 Primary Devices (Weirs and Flumes)

Primary devices are calibrated restrictions (structures) which are inserted into the channel, and which cause the upstream liquid level to vary proportionately with channel flow. A secondary device is used to measure variations in the liquid level.

Wastewater systems typically use two broad categories of primary devices: 1) weirs, and 2) flumes (see Figure 2). The relationship between liquid depth and flow rate depends upon the shape and dimensions of the restriction (primary device), and is calculated using a known equation called the head/flow or stage/discharge relationship.

The selection of whether to use a weir or a flume as a primary measuring device is based on a number of factors, including:

- Installation cost;
- Upkeep and maintenance cost;
- Expected head loss;
- Site configuration;
- Location configuration (i.e. space availability, slop, channel size);
- Rate of expected flow;
- Wastewater characteristics (i.e. suspended solids).

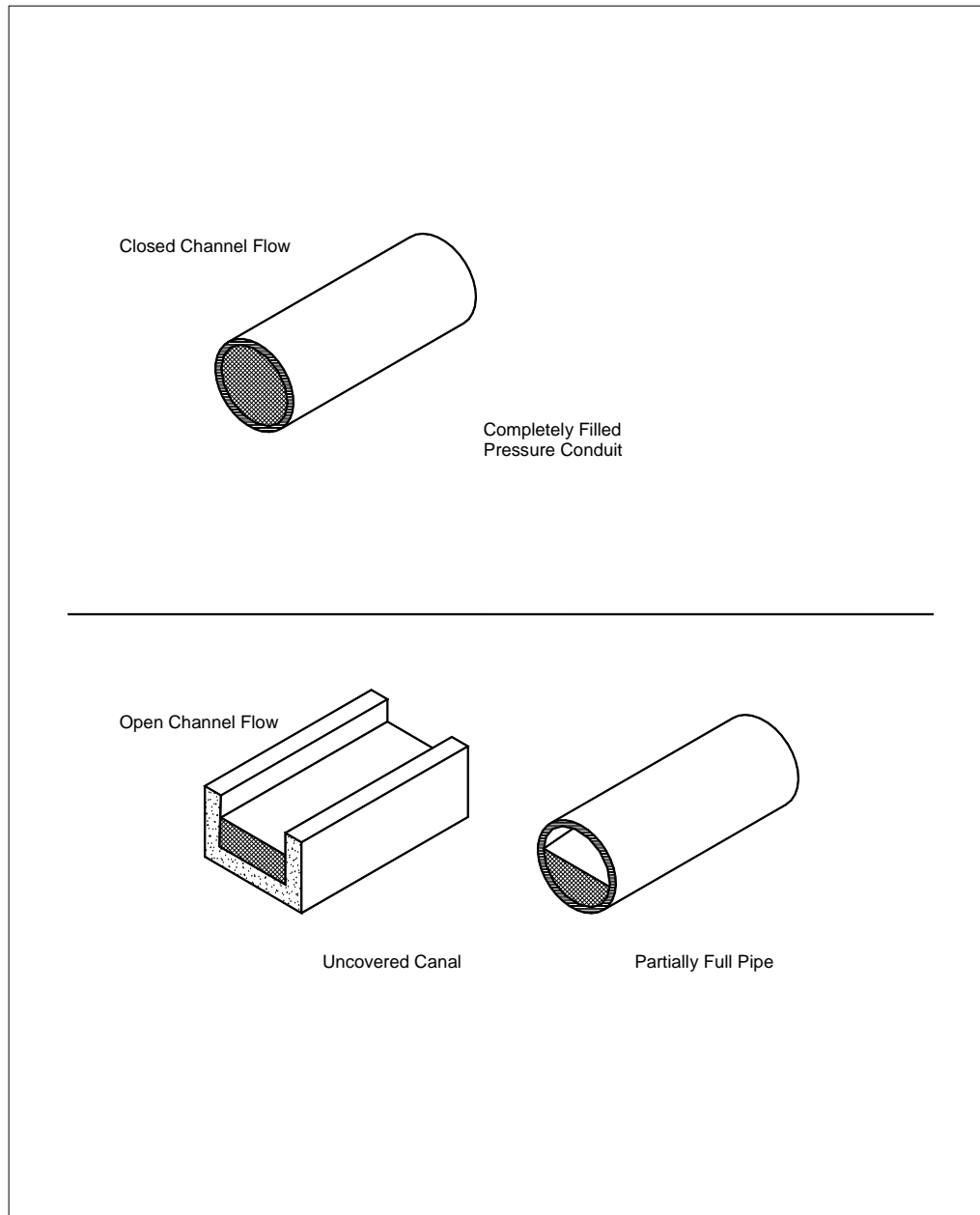

Figure 1. Closed Channel and Open Channel Flow

Measurement accuracy is generally not a factor in choosing between weirs and flumes as most types of weirs and flumes have a relative accuracy range of +/- 10% (Kirkpatrick and Shelley [1]).

The selection of the size of a primary device depends on the minimum and maximum flow rate expected for the location. The primary device must have a useful measurement range, which encompasses the minimum and maximum expected flow rates. It should be sized such that an appreciable change in liquid level occurs for the transition from the minimum to maximum flow.

A detailed discussion on the relative advantages and disadvantages of weirs and flumes can be found in the Channel Flow Measurement Handbook (Grant and Dawson [2]).

2.1.1 Weirs

Definitions and Description

A weir is a calibrated obstruction or dam built across an open channel over which the liquid flows, often through a specially shaped opening or notch (see Figure 2). Weirs are the simplest, least expensive, and most common form of primary measuring device. They are typically made of aluminum or fiberglass. Definitions for two related terms are:

1. Crest: the edge or surface over which the liquid passes;
2. Nappe: the stream of water leaving the crest.

2.1.1.2 Flow Conditions

There are two possible flow conditions through a weir.

1. **Free (critical) Flow Condition:** This condition occurs when the water surface downstream from the weir is far enough below the weir crest so that air flows freely below the nappe (the nappe is aerated), and only the head upstream of the weir is needed to determine the flow rate. The head of the weir is the vertical distance from the crest to the liquid surface in the upstream channel, and the measuring point should be upstream of the weir at a distance of at least three or four times the maximum head expected over the weir (see Figure 2).

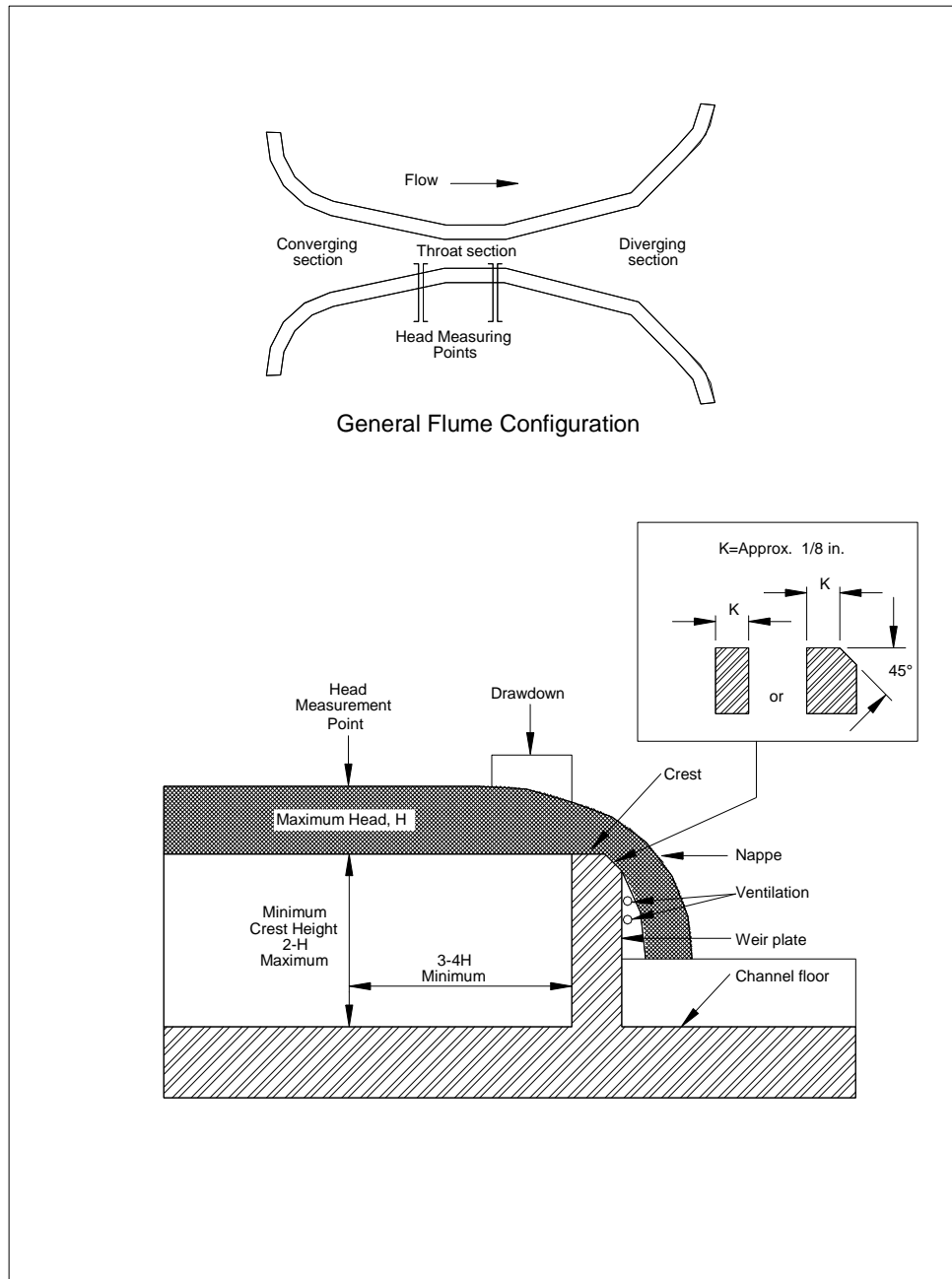

Figure 2. General Sharp-crested Weir Configuration

2. **Submerged (Subcritical) Flow Condition:** This condition occurs when the downstream water rises above the crest. Under submerged flow conditions the water depths upstream and downstream of the weir are needed to determine the flow rate. For wastewater applications weirs should be sized and installed to ensure that a free-flow condition is always maintained. Under free-flow conditions only one secondary device is required to measure liquid levels, located upstream of the weir.

2.1.1.3 Application

Weirs are well suited for measuring low flows, particularly where there is little head available. In addition to being used to measure flows, weirs are commonly used in wastewater treatment systems in secondary clarifiers to ensure uniform flow distribution along the effluent channel. Weirs are not generally considered suitable for raw wastewater (influent) flow measurement as solid materials can accumulate on the upstream side of the weir, which can disturb the conditions for accurate discharge measurement or even block the weir.

2.1.1.4 Common Weir Types

Weirs are classified according to the shape of the notch, and they can be sharp-crested or broad-crested (Pratt [3]). Sharp-crested triangular (V-notch), rectangular, and trapezoidal (Cipolletti) weirs are the most common type of primary measurement devices used in wastewater treatment plants (see Figure 3). Each notch shape has its own characteristic equation for determining the flow rate. The minimum and the maximum flow rates of each weir are given in standard tables (Grant and Dawson [2]).

V-notch (triangular) Weir

The V-notch weir consists of triangular notch cut in the channel which has its apex at the bottom, and the sides are set equally on either side of a vertical line from the apex (see Figure 4). The most commonly used angle sizes of the notch are 90, 60 and 45 degrees, although 120, 30, and 22½ degree weirs are sometimes used under special circumstances.

A V-notch weir has to fulfil all of the installation requirements shown in Figure 4 in order to accurately estimate the flow. V-notch weirs are particularly suited for low flows, and can be used for discharges with an order of magnitude difference in flow (i.e. a

range from 1 L/s to 10 L/s). The equation used to determine the discharge (head/flow) for a free-flowing V-notch weir is as follows (Grant and Dawson [2]):

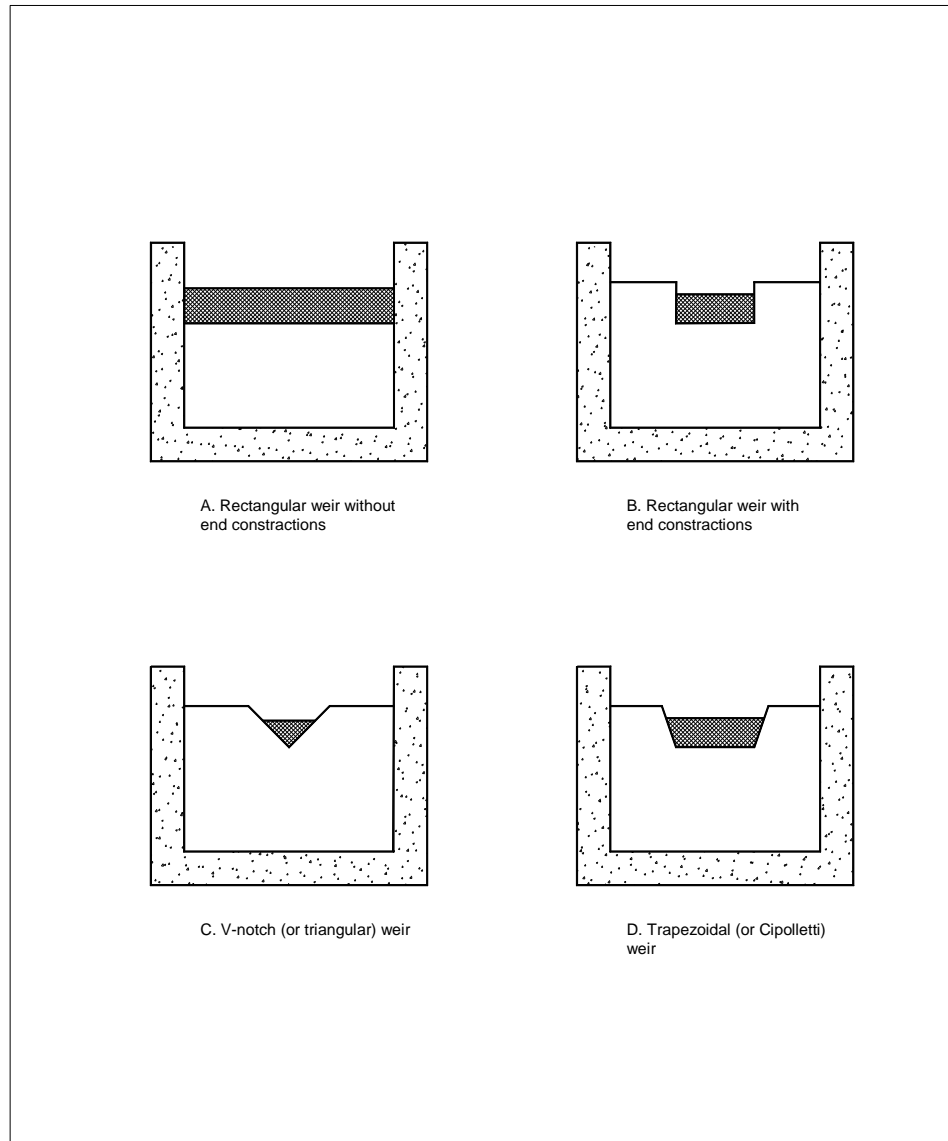

Figure 3. Various Sharp-crested Weir Profiles

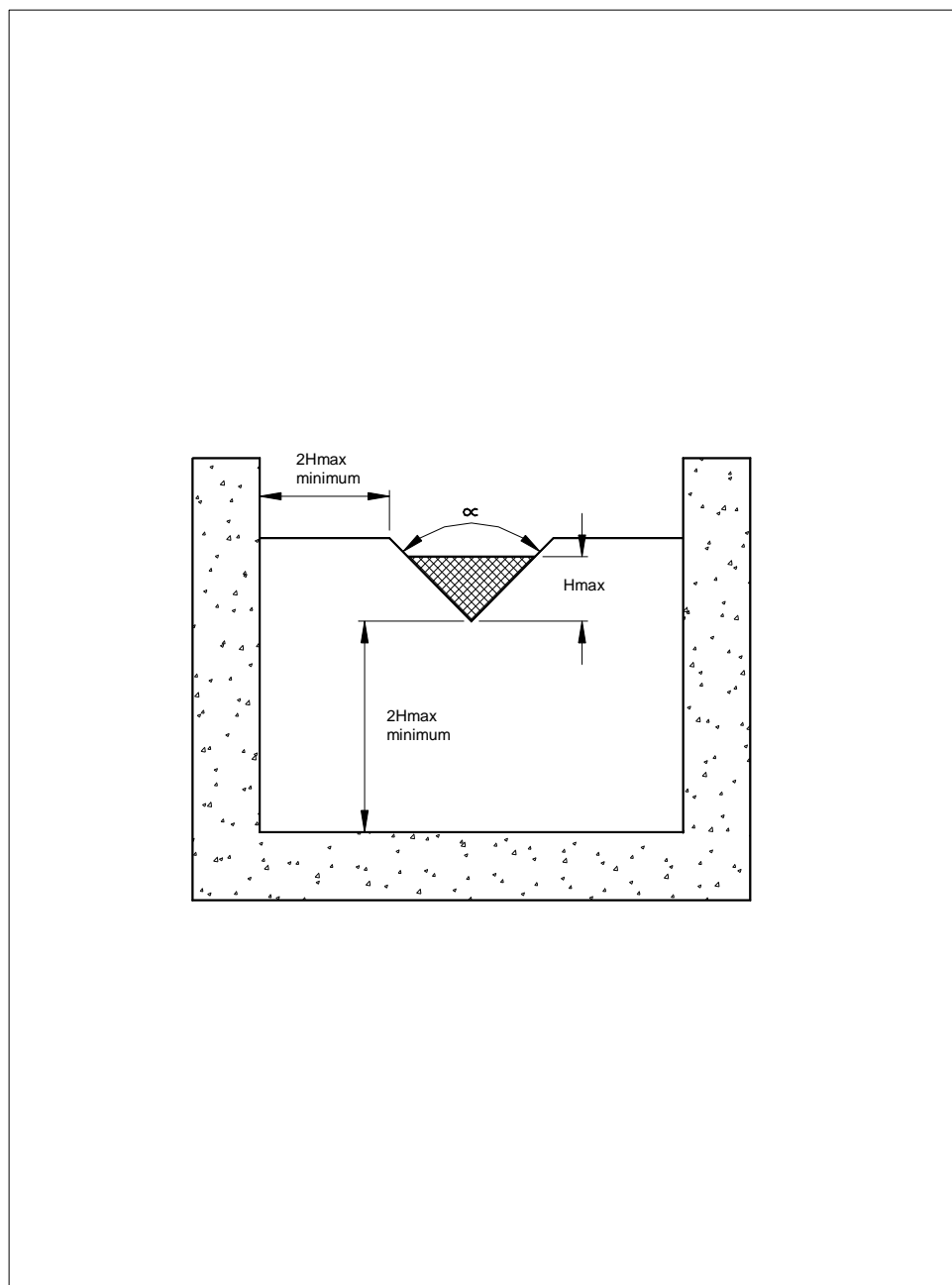

Figure 4. V-notch (triangular) Sharp-crested Weir

$$Q = K H^{2.5}$$

Where:

Q = flow rate

H = head on the weir

K = a constant which is a function of the angle of the weir and the unit of measurement

Rectangular (Contracted and Suppressed) Weir

The rectangular sharp-crested weir can be used in two different configurations:

1. *Rectangular Contracted Weir*: Consists of a rectangular notch cut in the channel to produce a box-like opening, where the horizontal distance from the end of the weir to the side walls of the channel are called the end contractions (see Figure 5a), and are used to:

- Reduce the channel width;
- Speed up the channel flow;
- Provide the needed ventilation as the flow passes over the weir.

2. *Suppressed Rectangular Weir*: When the end contractions are totally suppressed, and the channel's sides become weir's sides the weir is called a suppressed rectangular weir (see Figure 5b).

Experience has shown that when constructing a rectangular weir a crest length of 30 cm (12 inches) is the minimum that should be considered, and 15 cm (six inches) increments are used to increase the crest length up to 90 cm (36 inches). Beyond the 90 cm a 30 cm (12 inches) increment is used to suit a particular installation.

Installation requirements should be as shown in Figure 5b, and 5a. Special care often needs to be taken to ensure proper ventilation of the nappe - usually through the placement of vent pipes in the side walls to allow air to reach under the nappe.

The minimum head should be at least 5 cm (2 inches) to prevent the nappe from clinging to the crest, and generally the maximum head is recommended not to be more than one half the crest length.

The equation below is used to determine the discharges (head versus flow rate) of a free flowing rectangular weir with two end contractions:

$$Q = K (L-0.2H) H^{1.5}$$

$$Q = 1838 (L-0.2H) H^{1.5} \text{ (l/s), L (m)}$$

$$Q = 6618 (L-0.2H) H^{1.5} \text{ (m}^3\text{/h), L (m)}$$

Where:

Q= flow rate

H= head on the weir

L = crest length of the weir

K = constant dependent on measurement units

Trapezoidal (Cipolletti) Weir

A trapezoidal weir is a rectangular weir with an end contraction, which has its sides inclined outwardly, producing a trapezoidal opening as shown in Figure 6. When the sides are inclined in the ratio of four vertical to one horizontal the weir is known as Cipolletti weir. To be able to measure the flow rates accurately, trapezoidal weirs have to fulfill the installation requirements shown in Figure 6. The minimum head should be at least 5 cm (2 inches) to prevent the nappe from clinging, and the maximum head is recommended not to be more than one half the crest length. The discharge (head versus flow rate) equation of a free flowing Cipolletti weir is as follows:

$$Q = K L H^{1.5}$$

$$Q = 1859 L H^{1.5} \text{ (l/s), L (m)}$$

$$Q = 6692 L H^{1.5} \text{ (m}^3\text{/h), L (m)}$$

Where:

Q= flow rate

H = head on the weir

L = crest length of the weir

K = a constant dependent on the measurement units

Other Weirs

The most commonly used weir types in the wastewater flow measurements are the one discussed above. But there are other special profiles, and less-common types of primary devices classified as weirs, such as broad-crested weirs, and compound weirs, which are used in particular site configurations or to achieve a certain head/discharge relationship (see Figure 7).

The most common of these special designed devices is the proportional weir or Sutro weir. Please refer to Pratt [3] for more details on alternative weirs.

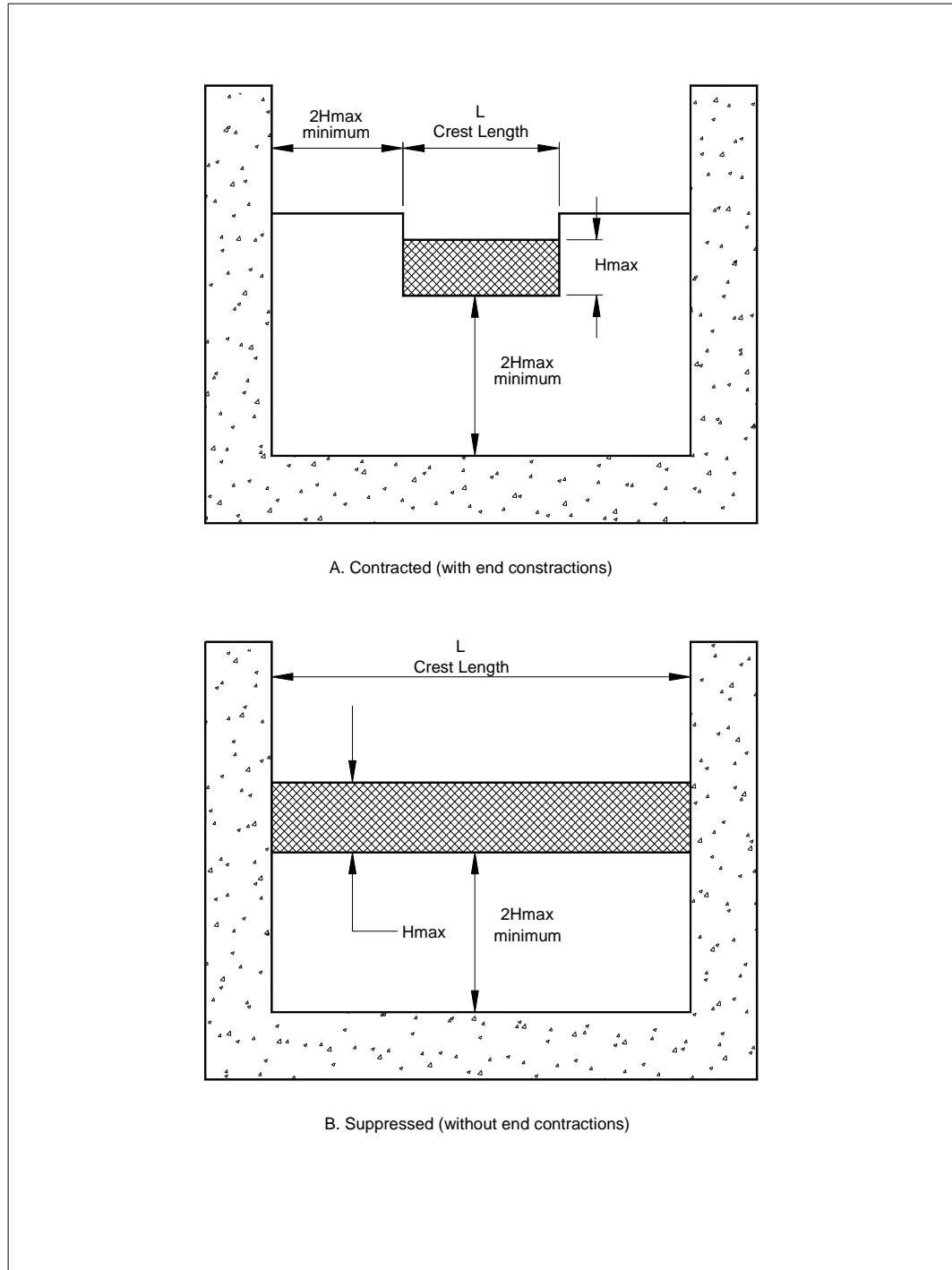

Figure 5. Rectangular Sharp-crested Weirs

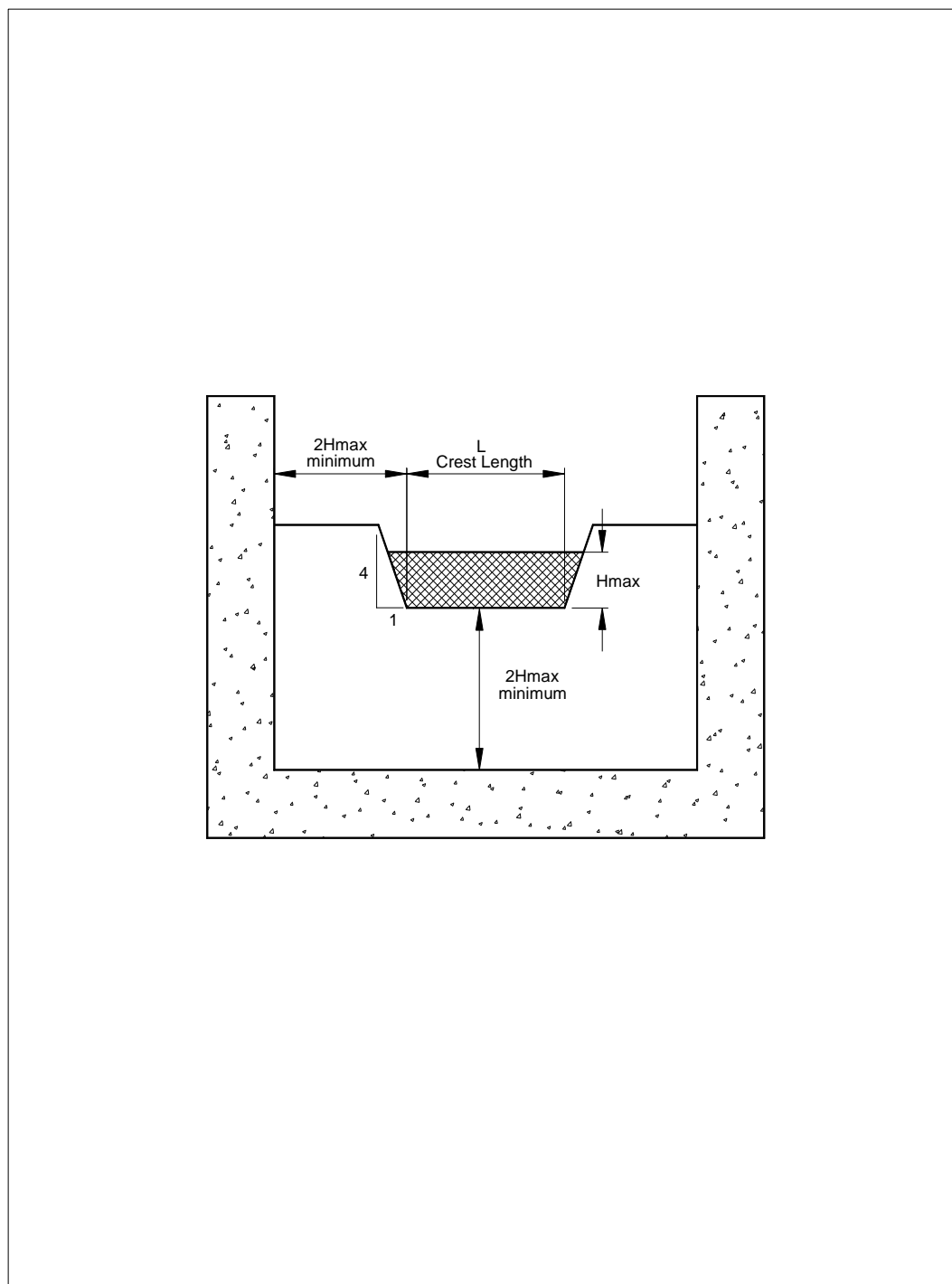

Figure 6. Trapezoidal (Cipolletti) Sharp-crest Weir

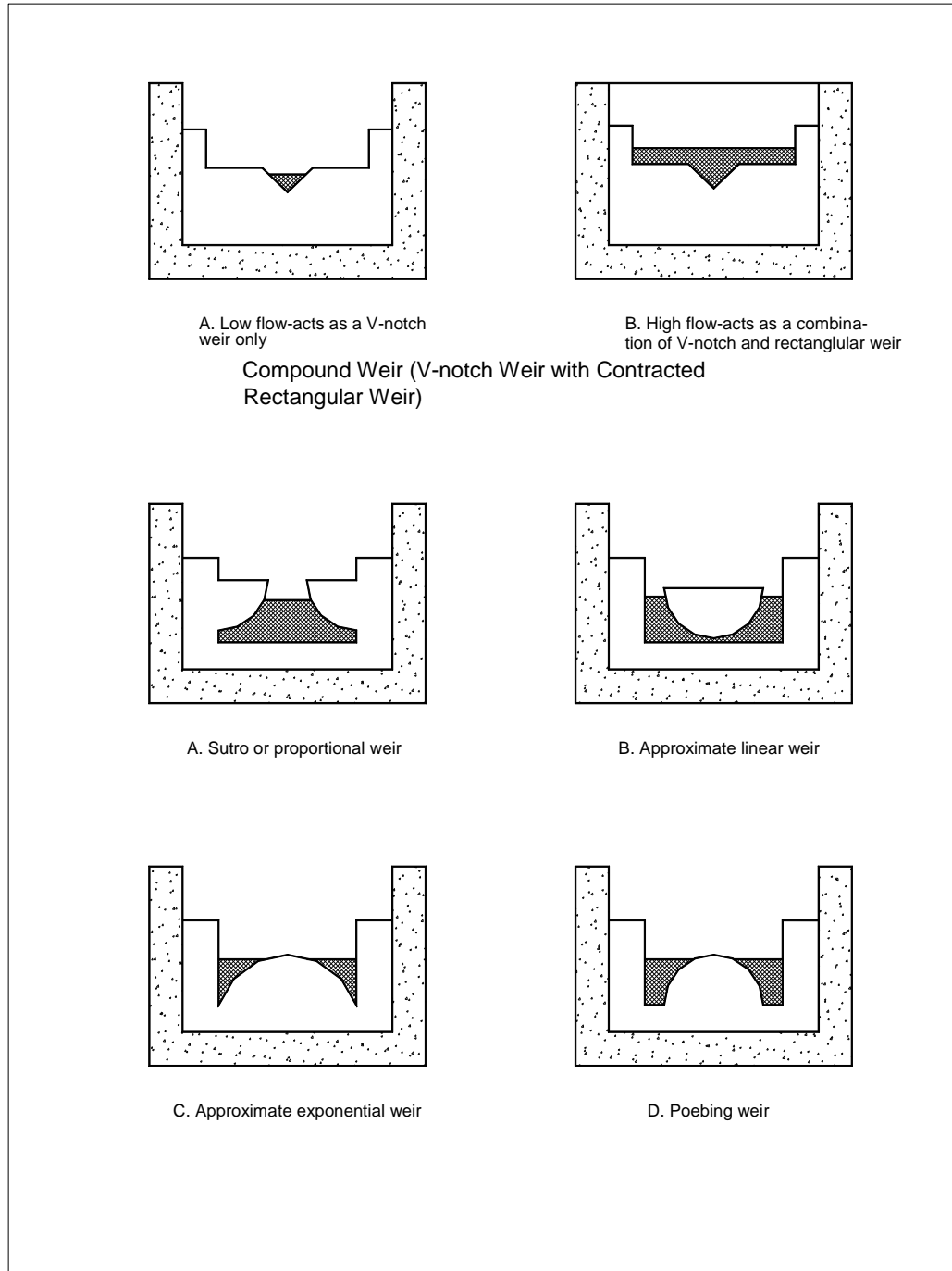

Figure 7. Special Sharp-crest Weir Profiles

2.1.2 Flumes

2.1.2.1 Definition and Description

Flumes are the second class of commonly used primary measuring devices. They are specially shaped channel restrictions, which change the channel area, and slope. This change increases the velocity, and the level of the liquid, flowing through the flume (see Figure 2). They can be made from various construction materials such as fiberglass, and concrete, and their structure is composed of three main components:

1. Converging section used to restrict the flow;
2. Throat section;
3. Diverging section used to ensure a free flow condition.

The flume should be installed to ensure it operates under a free-flow condition. The flow rate in the channel is determined by measuring the liquid level at a specified point in the flume. For more detail on various flume design approaches refer to Kirkpatrick and Shelley [1].

2.1.2.2 Flow Conditions

Flumes can be categorized into three main groups based on the flow-state through the flume:

1. Subcritical;
2. Critical;
3. Supercritical.

Similar to a weir, there are two flume discharge conditions, which can occur:

1. Free-flow condition, when there is insufficient backwater to reduce the flow rates. Under this condition only the upstream head is needed to determine the flow rate.
2. Submerged-flow condition, when backwater is high enough to reduce the discharge. Under this condition both the head upstream of the flume and in the throat are needed to determine the flow rate. The point at which the flow changes from free flow to submerged flow is called the submergency point.

It is expressed as a percentage, which is the ratio of downstream liquid depth/ upstream liquid depth and it varies from size to size being as low as 55% and as high as 80% through the range of throat sizes from 2.54 - 240 cm.

Flumes should be sized and installed to ensure that a free-flow condition is always maintained. Under free-flow conditions only one secondary device is required to measure liquid levels, located upstream of the flume.

2.1.2.3 Application

Flumes are usually used to measure flow in open channels where higher flows are expected, and are better suited for use with flows containing sediment or solids than weirs. Flumes are self-cleaning, and require less maintenance in comparison to weirs, but they still need to be cleaned specially when used with sewage flows where more sediments are expected.

2.1.2.4 Common Flume Types

Some of the commonly used flume types are:

Parshall Flume

Parshall flumes (see Figure 8) are primarily used for permanent installations. Their design and sizes are dictated by the throat width, which for wastewater applications is usually a minimum of 25 mm (one inch). The throat width and all other dimensions must be strictly followed so that standard discharge tables can be used (Grant and Dawson [2]). Parshall flumes in turbulent flows are typically equipped with an integral floatwell to house the secondary-measuring device, and to ensure a correct liquid level reading. They are designed in a way to be able to withstand a high degree of submergence without affecting the rate of flow, and to have a self-cleaning capability as shown in Figure 8.

The flow rate in the Parshall flume is determined by measuring the liquid level one third of the way into the converging section, and the discharge rates are determined using the following head versus flow relationship:

$$Q = K H^n$$

Where:

Q = flow rate

H = head measured at point Ha (Figure 8)

K = constant, function of throat width and measurement units

n = constant (function of throat width)

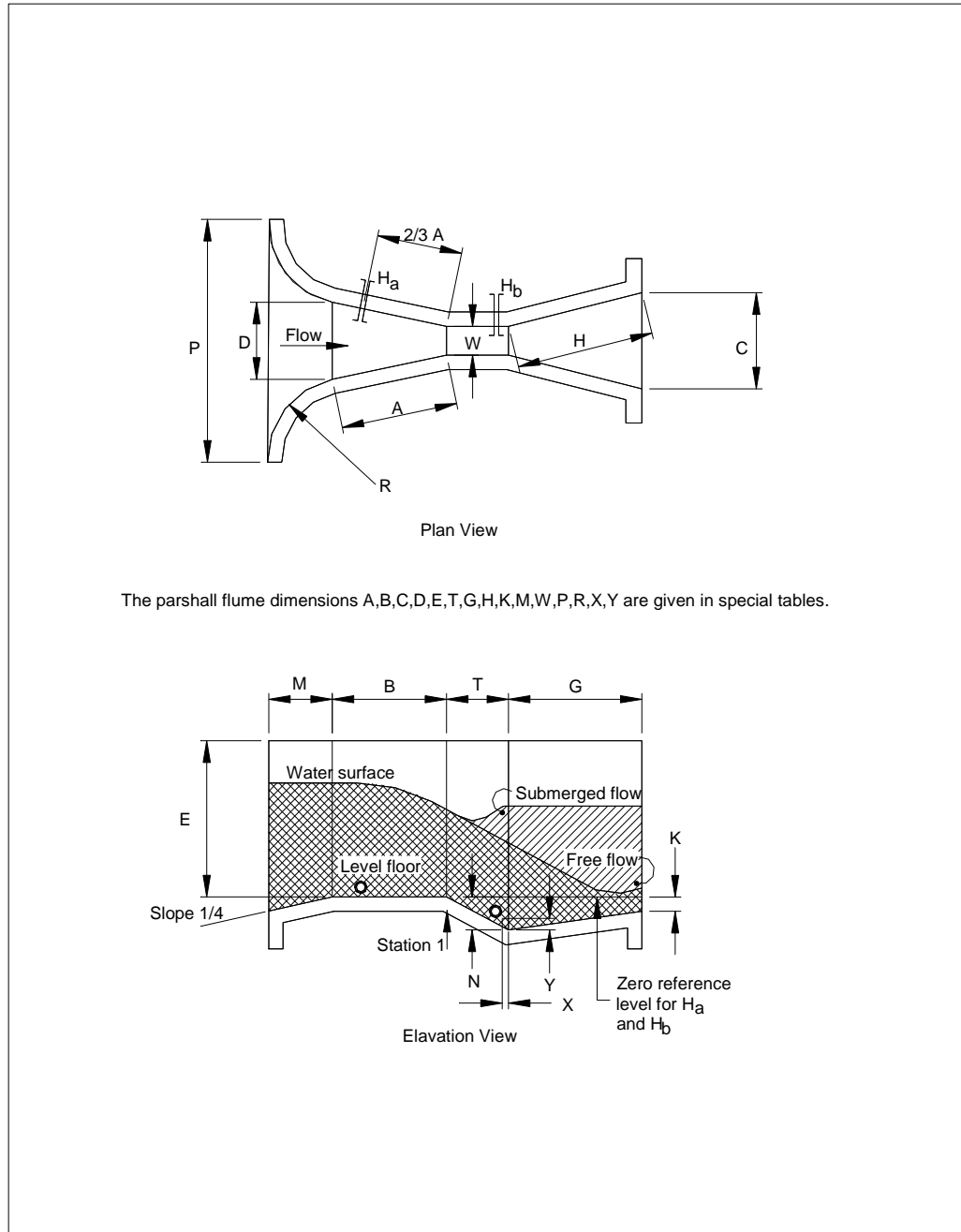

The parshall flume dimensions A,B,C,D,E,T,G,H,K,M,W,P,R,X,Y are given in special tables.

Figure 8. Parshall Flume

Palmer - Bowlus Flume

The Palmer-Bowlus flume also produce a high velocity critical-flow in the throat by constricting the flow through the flume. The Palmer-Bowlus flume was designed to be installed in an existing channel, and its measurement accuracy is less sensitive to upstream flow disturbances (e.g. turbulent flow conditions) than the Parshall flume. It is often used in manholes or open round or rectangular bottom channels, or in channels with excessive slope and/or turbulence (see Figure 9a). The flume sizes are designated by the size of the pipe or conduit into which they fit, and the volume of expected flow, not by the throat width as is the case with the Parshall flumes. Palmer-Bowlus flumes are available from various manufacturers to fit pipe sizes ranging from 10 to 100 cm (4 - 42 inches), and larger sizes can be specially ordered.

The flow rate through a Palmer-Bowlus flume is determined by measuring the liquid depth at a point one-half pipe diameter upstream from the flume throat, and the most popular and preferred design for circular pipes and conduits is the Palmer-Bowlus flume which has a trapezoidal throat (see Figure 9b).

The Palmer-Bowlus flume main advantages comparing to Parshall flume are:

- less energy loss;
- minimal restriction to flow;
- Easy installation in existing conduits.

Because of possible wide variation in Palmer-Bowlus design, and different manufacturers, it is very important to assure that the rating curve (head versus flow) being applied is the correct one for that particular flume. The rating curve should be the one provided by the manufacturer.

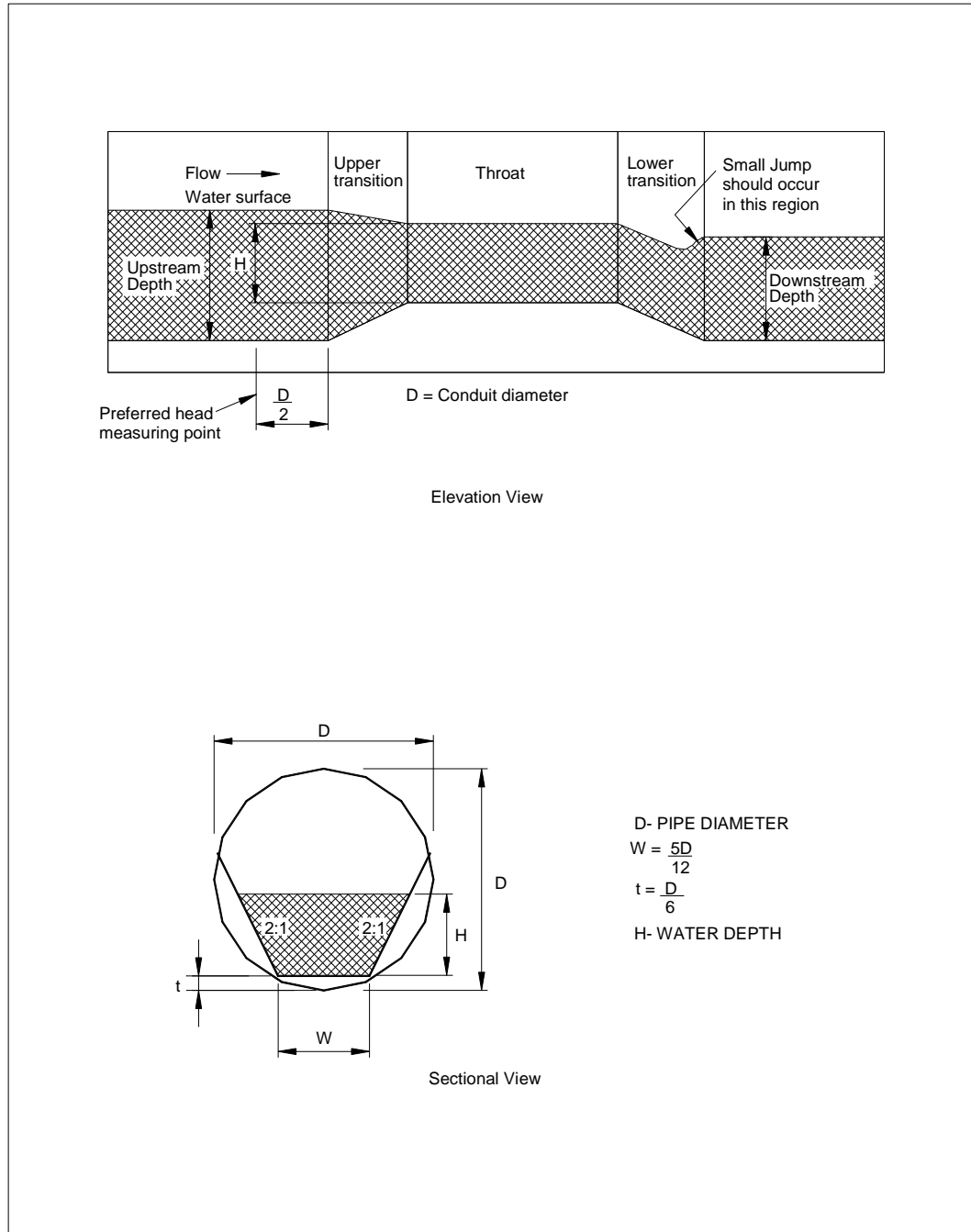

Figure 9A. Palmer-Bowlus Flow Measuring Flume

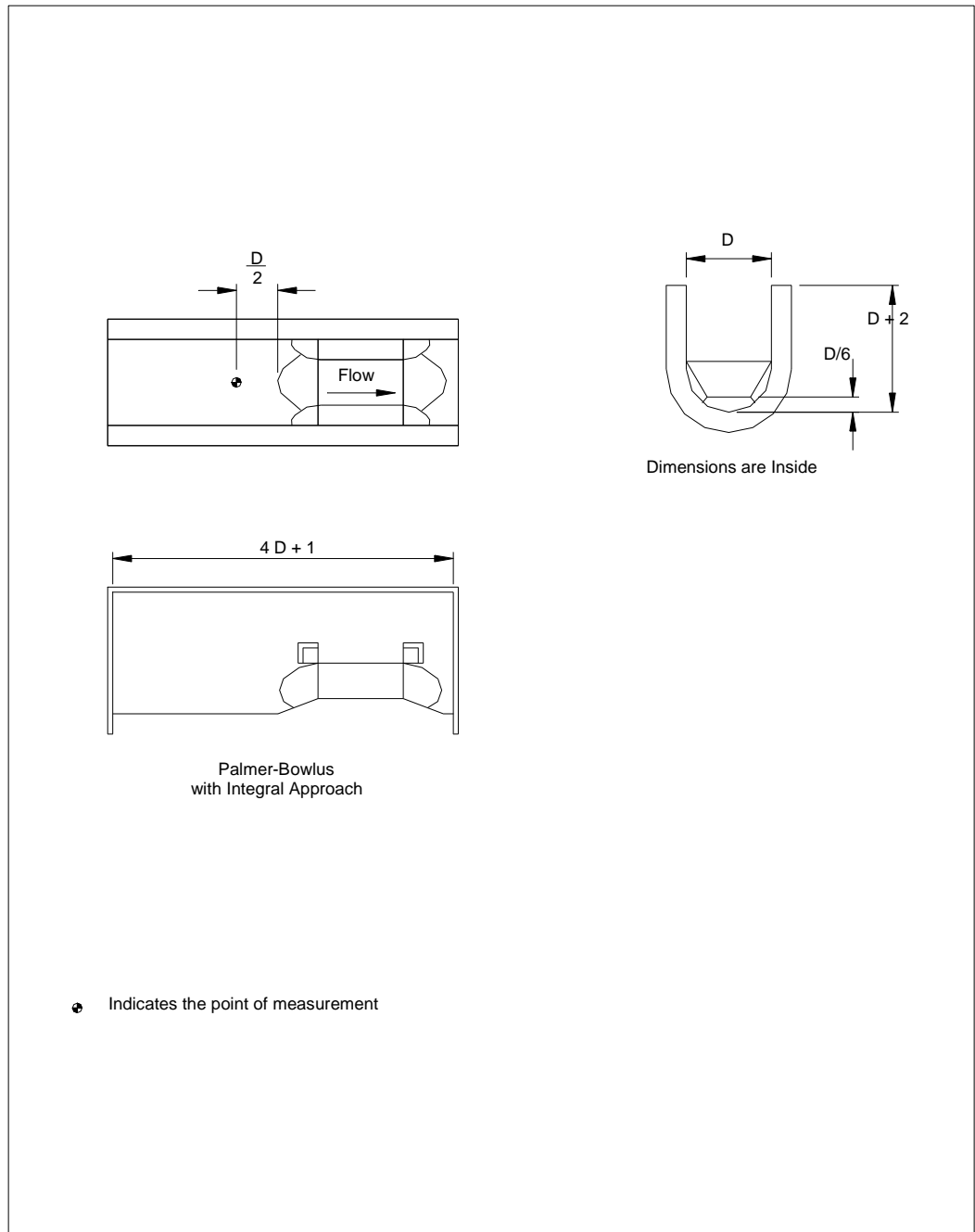

Figure 9B. Palmer-Bowlus Flow Measuring Flume

Other Flumes

There are a number of other types of flumes, which can find application in effluent flow measurement. These are usually purchased prefabricated from one of the many flume manufacturers to meet special design criteria or to solve a specific problem. Some common types are:

- Leopold-Lagco Flume: a proprietary flume manufactured by the F.B. Leopold Company (see Figure 10). They are mainly used in the measurement of sewer flows, and their sizes are designated by the size of the conduit in which they are to be installed and the expected range of flows. They are available to fit pipe sizes ranging from 10 - 183 mm (4 to 7.2 inches). They provide an accurate flow measurement when used on a minimum grade or grades up to 2%. The best location for the level measuring point is at a distance of 1/12 D or 25 mm (one inch) minimum upstream of the flume. The discharge equation is as follows:

$$Q = K D^{0.953} H^{1.547}$$

Where:

Q = flow rate

H = head

D = pipe diameter

K = constant function of units

HS, H, and HL flumes were developed by the U.S. Department of Agriculture (USDA). They are capable of monitoring flows that vary over wide ranges (100:1) with a high degree of accuracy. As per Grant and Dawson [2] the maximum flow rates range from:

2.4 - 23.2 L/s

8.6 - 83.6 m³/hr for HS flume

9.5 - 2380 L/s

34 - 8580 m³/hr for H flumes

586 - 3290 L/s

2110 - 11,800 m³/hr for HL flumes

When installing an H-type flume it is recommended that the approach channel is rectangular, having the same depth and width as the flume, and a length three to five times the depth of the flume.

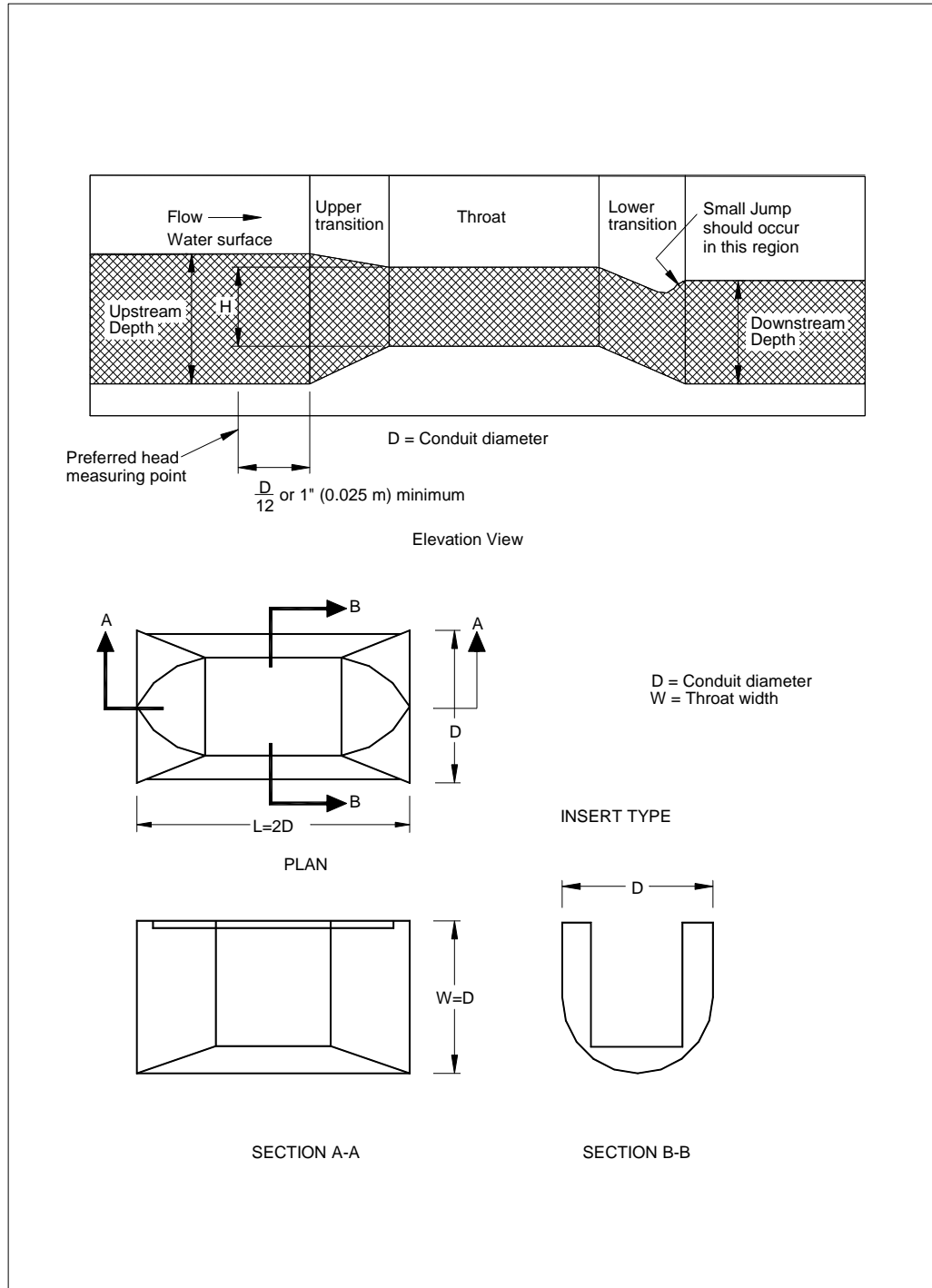

Figure 10. Leopold-Lagco Flume

Trapezoidal flumes have been used by the U.S. Department of Agriculture (USDA) to measure small flows. Its sloping sides permit a very wide range of measurable flow and cause a minimum backwater. Various trapezoidal flumes have been constructed to measure maximum flow rates ranging from 1-2,650,000 m³/hr (0.010 to 26,000 cfs).

- Cutthroat flumes were developed by Utah State University Water Resources Laboratory and as the name indicates the flume does not have a throat section (see Figure 11). The flume is a flat-bottomed device and its main advantage is extreme simplicity of form and construction. It is recommended that cutthroat flumes be used in channels where free and submerged flow conditions may be desired. For more detail on these types refer to Grant and Dawson [2].

2.1.3 Installation and Design of Primary Flow Measurement Devices

The various flow-monitoring methods have distinct advantages or disadvantages under different conditions and, therefore, specific installation requirements. Prior to the device installation a field inspection is recommended to investigate hydraulic conditions in the conduit such as, flow direction, obstructions, expected flow rates, presence of debris, and flow regime. The manufacturer's recommendations for installation always need to be followed.

2.1.3.1 Weir Installation

To ensure accurate discharges measurement, there are certain general design requirements that apply to all weir types:

- The upstream face of the weir should be smooth and perpendicular to the axis of the channel;
- The connection to the channel should be waterproof;
- The length of the weir or the notch angle must be accurately determined;
- The weir should be ventilated if necessary to prevent a vacuum from forming below the nappe;
- The height from the bottom of the channel should be at least 2 times the maximum expected head of the liquid above the crest;
- The approach section upstream of the weir should be straight for at least 20 times the maximum expected head of liquid. For more design requirements refer to Grant and Dawson [2];
- The weir should be made of a thin plate 3 - 6mm;

- (1/8 - 1/4 inch) thick with a straight edge or thicker with a downstream chamfered edge;
- The device for measuring the head should be placed upstream at a distance of at least three times the maximum expected head on the weir.

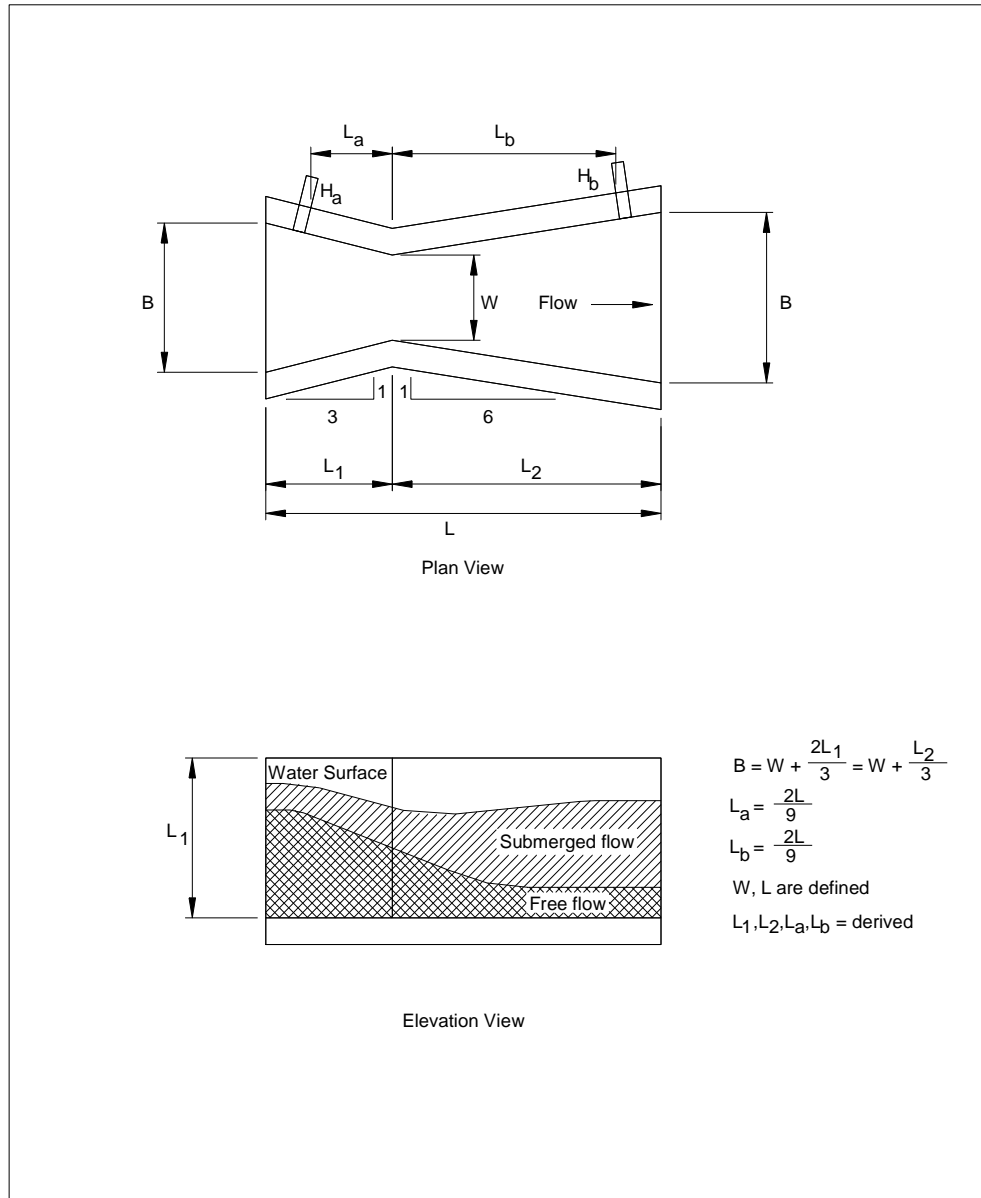

Figure 11. Dimensional Configuration of Rectangular Cutthroat Flume

2.1.3.2 Flume Installation

The following points need to be taken in consideration when selecting, and installing a particular type of flume:

- A flume should be located in a straight section of the open channel;
- The flume should be set on a solid foundation;
- The approaching flow velocity should be free of turbulence, and waves, and well distributed in the channel;
- The upstream banks should be high enough to sustain the increased liquid depth caused by the flume installation;
- If possible always install the flume to obtain a free flowing condition.

2.1.4 Calibration of Primary Flow Measurement Devices

Some form of calibration method must be provided for in every field installation. To calibrate the complete measuring system there are three main methods commonly used:

1. Volumetric flow measurement;
2. Dilution (dye);
3. Point velocity and depth measurement.

2.1.4.1 Volumetric Method

The volumetric method is considered to be one of the most accurate methods for obtaining liquid-flow relationships. This method is typically used for only small volumes of liquid, but can be applied to larger flows if suitably large enough basins are available. The volumetric method involves determining the amount of time to fill a tank or container of a known volume. The rate of flow is calculated by dividing the volume by the fill time.

The volumetric method requires only a sensor to monitor liquid level, or to determine when the tank volume is full. It can be applied to sewage pumping stations as a routine method of estimate sewage flows by recording the off-on times of the pumps through telemetry or SCADA systems. There is also a commercially available product, which uses this principal to estimate flow (Volumeter-Model 300 made by Marsh-McBirney, Inc.).

2.1.4.2 Dilution (dye) Method

This method measures the flow rate by determining the dilution of a tracer solution. The dye is continuously injected at a constant rate, from a distance far enough upstream to ensure the dye is uniformly concentrated through the cross section at the point of measurement. The dye concentration change is proportional to the change in flow rate.

2.1.4.3 Point Method

This method requires the collection of depth and velocity measurements at specific points across the channel cross section to determine the flow, which is equal to mean velocity x cross sectional flow area ($V \times A$). The Two-point method can be used to determine the mean velocity.

2.1.5 Maintenance of Primary Flow Measurement Devices

Proper function and accurate flow measurement are directly related to the level of maintenance of primary measuring devices.

A frequent inspection and maintenance of the devices is recommended on a bi-weekly basis to:

- Clean sediment and debris from the upstream channel;
- Check the primary and secondary devices zero-setting.

2.2. Secondary Measuring Devices (Flow Meters)

Secondary measuring devices are devices used to measure liquid level variations in conjunction with primary measuring devices (weir or flume). The liquid level is used to estimate the flow rate based on the known liquid-level flow-rate relationship of the primary measuring device.

2.2.1 Floats

Historically, floats have been the most commonly used secondary devices used for monitoring liquid level variations, because of their relatively low cost, and availability. However, this has changed in recent years due to the decreased cost, increased availability, and improved reliability of electronic measuring devices such as ultrasonic sensors.

Floats are suspended in a stilling well area, located to the side of the flume. The stilling well is connected to the channel by a slot or port, such that the liquid level in the stilling well is the same as the critical hydraulic level in the flume. The stilling well is required for a float system, as a float could not be placed in the flume channel without creating a hydraulic

disturbance, which would interfere with the flume hydraulics and measurement accuracy. The stilling well also prevents the float from being affected by any hydraulic surges.

The float is usually connected by a cable to chart recorder pulley, and as the float rises and falls, the pen on the chart recorder moves correspondingly. A movable weight can be attached to the cable, which keeps it taut (see Figure 12). The cable will cause the rotating member to be angularly positioned proportional to the level of the liquid in the primary device. When the float is used in a combination with an electronic relay the level is read electronically. A system of gears enables the chart recorder to be calibrated and record information in specific units (i.e. inches of liquid, flow in gallons, etc.).

Floats include moving parts, which are subject to wear, and are subject to build-up of grease and solids. Thus they require periodic maintenance and repair. The accuracy of floats used as level measuring devices ranges from 1.5 mm – 6 mm (0.005 ft - 0.020 ft) (Irwin [4]).

2.2.2 Electrical (Capacitance Probe)

The capacitance probe utilizes the electrical conductivity of the liquid to monitor variations in liquid level. Electrodes or probes are suspended vertically into the liquid being controlled, thus completing a circuit which actuates the control relay. The changing liquid level causes an electrical capacitance change, where the difference in capacitance indicates the depth of the liquid. Electrodes and holders should be selected according to the specific characteristics of the liquid involved, and the lengths required to monitor the potential range in liquid level. Electrode holders and electrodes are available for measuring liquid level in temperature up to 232 C0, and pressure of 13790 kpa pressure (MagneTek Controls [5]).

The changing liquid characteristics, or coatings of grease, hair, or solids can adversely affect the accuracy of the electrical system, and the plates are subject to damage by floating debris. Thus this method of measurement can be used to measure flow in raw sewage or in-process flows only if applied as a short-term installation. Capacitance probes are better suited to measuring effluent flows, which are less likely to contain materials which will interfere with measurement. Electrical type level measurement devices are available to measure the liquid level with 0.5 % to 1 % accuracy of full-scale level (Irwin [4]).

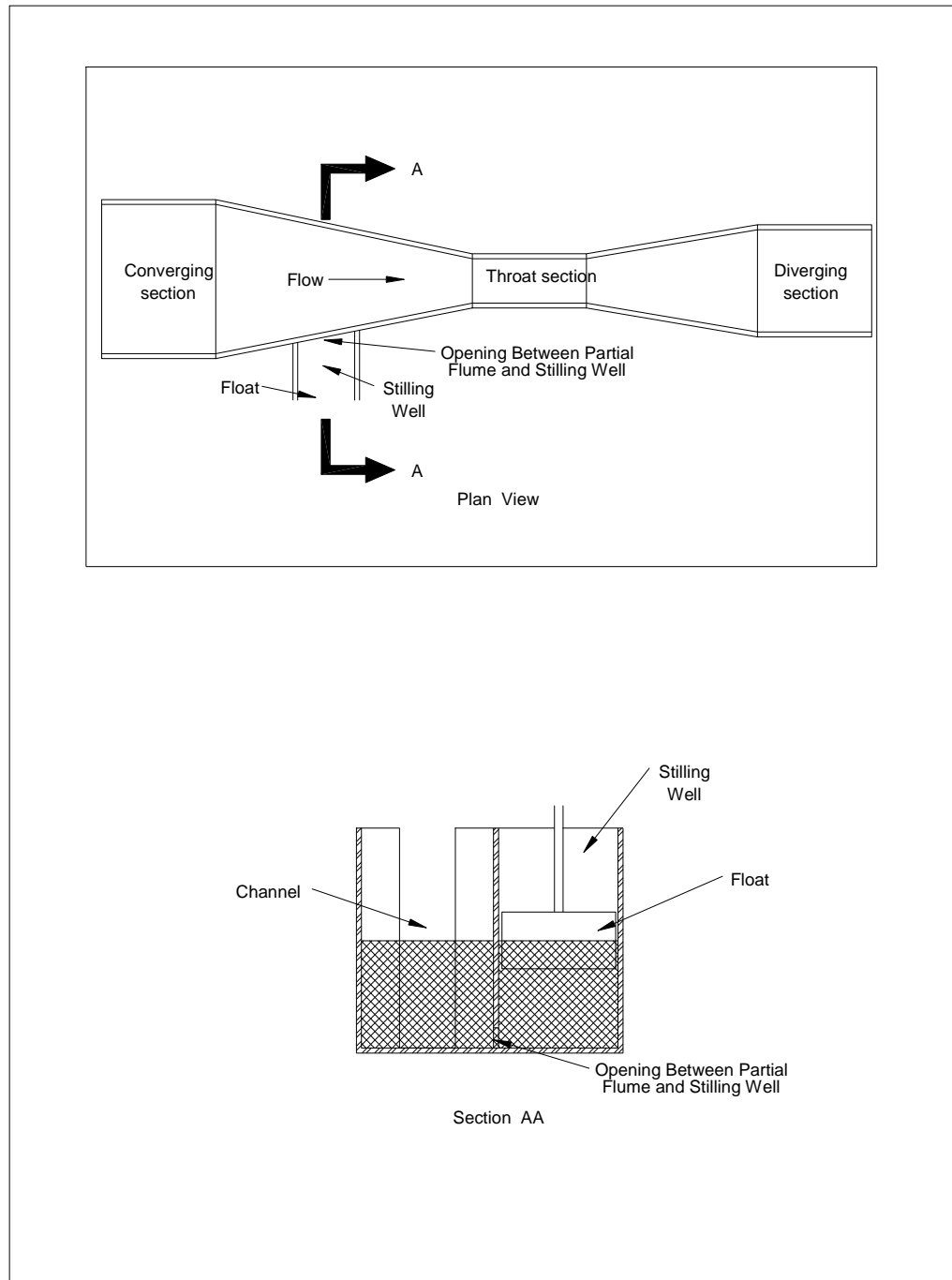

Figure 12. Float level measuring device

2.2.3 Ultrasonic Level Sensors

An ultrasonic sensor mounted above the flow stream transmits a sound pulse that is reflected by the surface of the liquid. The time required for a pulse to travel from the transmitter to the liquid surface and back to the receiver is used to determine the liquid level. Ultrasonic systems are available to monitor levels from a few centimeters and up to 61 meters (Milltronics Process Measurements [6]). There are various types of transducers used, and their selection depends on the material and application range to be monitored. The distance between the transducer and the transceiver depends on the type of the transducer used (available for distances up to 366 m [6]). They can operate under pressure up to 200 kPa, and temperature range -40C° to 150C° [6] with range of accuracy 0.25%-0.5%. The selection of the proper transducer is based on:

- Maximum level to be measured;
- Characteristics of the transducer (pressure, temperature, corrosivity, etc);
- Mounting configuration.

Since the ultrasonic level sensors are fixed above the flow stream, grease, suspended solids, silt, corrosive chemicals in the flow stream, and liquid temperature fluctuation do not affect the sensors. However, ultrasonic systems may be affected by wind, high humidity, air temperature, radio and electromagnetic waves, rain, shock waves, and floating foam and debris, and they are not suitable for use in very narrow channels.

2.2.4 Bubblers

Bubblers consist of an air tube, which is anchored in the flow stream at a fixed depth along the side-wall of a primary device (flumes or weirs). Bubbler flow meters use an air compressor to force a metered amount of air through a line submerged in the flow channel. The pressure needed to force the air bubbles out of the line corresponds to the hydraulic head of the liquid above the tube. Thus the pressure in the tube is proportional to the liquid level in the primary device, and can be measured with a mechanical pressure sensor or an electronic pressure transducer.

Some bubblers have a built in plotter, flow conversion equations, telemetry capabilities, and data storage (ISCO 3230). This allow them to provide and transmit a time based level or flow rates and total flow.

Bubblers are highly velocity sensitive, and readings may be greatly influenced by the non-vertical installation of the tube, disturbance of the tube by floating debris, suspended solids, and rapidly rising and falling head levels. Thus periodic maintenance (cleaning) is required. To prevent the building-up of potentially clogging solids some bubblers have an exclusive automatic bubble line purge.

The purge can be set to occur at selected time interval or can be activated manually. Usually special software is used to sense the rising heads and automatically increase the bubble rate to maintain the maximum accuracy.

2.3 Selection Criteria for Secondary Measuring Devices

The most important criteria to be considered in the selection of a secondary measuring device includes:

- Type of application; is the metering device appropriate for open or closed conduit flow?
- Proper sizing for range of depths to be measured; is the device appropriately sized for the range of flows that needs to be monitored?
- Fluid composition, does the device have the recommended minimum clear opening for the fluid being monitored, and is it compatible with the fluid?
- Accuracy and repeatability: is the stated accuracy of the component consistent with overall system accuracy?
- Installation requirements; is there enough length in front and behind of the device, and are measuring devices accessible for service?
- Ease of maintenance; how often the device needs to be cleaned, and are cleaning systems available?
- Operating environment; where necessary is the equipment resistant to moisture and corrosive gases?
- Head loss.

2.4 Installation of Secondary Flow Measurement Devices

Proper installation of secondary flow measurement devices is directly related to the amount of information collected regarding the location, characteristics of the liquid to be monitored, operating environment (temperature, gases, moisture...), and flow conditions.

The manufacturer's installation instructions should always be followed. The following recommendations should be taken in consideration when installing these devices:

- The upstream section should be cleared of debris and sediments (at least 15 diameters upstream from the sensor);

- The level sensor in an open channel should be housed in a stilling well;
- When applicable, it should be ensured that the sensors are installed centered and flat on the conduit bottom;
- If the flow velocity is greater than 1.5 m/s, better results may be obtained by mounting the sensor facing the downstream direction, if possible.

2.5 Calibration of Secondary Flow Measurement Devices

Level sensors are pre-calibrated at the factory or are calibrated by the distributor upon installation using the equipment available from the meter manufacturer. The calibration of the level sensors is simply checked by comparing the sensor reading to the tape measurement of the depth. In open channel systems a known depth of flow is simulated, then verified if the sensor read and totaled correctly for that depth. If any discrepancies are discovered, the manufacturer's instructions for re-calibration should be followed.

2.6 Maintenance of Secondary Flow Measurement Devices

Regular site inspection and maintenance is recommended on a weekly or bi-weekly basis. Frequency is dependent on type of instrument – ultrasonic level sensors tend to be relatively maintenance free. The inspection should include:

- Clean the sensor and the instrument enclosure;
- Remove sediment and debris from around the cable and sensor cables;
- Check the accuracy of the time display;
- Check the power availability;
- Compare the depth reading to a manual measurement of the depth, before and after clean-up, and if the difference in depth is greater than 5 cm (two inches) or 10% the effective range, the meter should be removed for re-calibration;
- Note any irregularities;
- When devices are used to measure raw wastewater a flushing system should be provided where appropriate. Self-cleaning electrodes are available for use with used with magnetic flow meters using either high frequency ultrasonic waves or heat;
- For long-term installations, complete maintenance is required every six months, and a record of all flow monitoring, cleaning, and maintenance activities must be kept. The maintenance record should describe the system condition before and after any work was undertaken.

The maintenance should include:

- Removal of sensors and cables for cleaning;
- Cleaning of the pipes upstream for at least 15 pipe diameters upstream of the sensor location.

3. Closed Channel Flow Measurement

Closed channel flow is flow in completely filled pressure conduit (pipes) (see Figure 1). There are three main methods used to measure the flow rates in closed conduits.

1. Insertion of an obstruction to create a predictable head loss or pressure difference.
2. Measurement of the effect of the moving fluid (momentum change, magnetic field shift, etc.).
3. Measurement of increment unit of fluid volume.

The most common devices used for flow measurement in closed channels are: Venturi meters, flow nozzles, Orifice meters, magnetic meters, Doppler meters, and Pitot tube flow meters. Not all these devices are suitable for specific waste-waters. These commercially available measuring devices use the Principle of Continuity, and one of several equations that define flow motion such as the energy equation or the momentum equation. Others use physical principals such as Faraday's law of electromagnetic induction, used in magnetic flow meter, and Ohm's law utilized in hot wire anemometers measuring the rate of cooling by flow of fluid past an electrically heated resistance wire.

The simplest way to measure pressure and pressure differential in a closed pipe is to use a vertical standpipe called a Piezometer tube connected to a tap on the pipe in which the pressure is to be measured. If the piezometer tube has a U-shape the instrument than is called a manometer. To produce uniform conditions in the closed pipe it is recommended that at least a length of 6 times the pipe diameter be straight in front of the measuring device (Simon and Korom [8]). A straight run of about 5 times the pipe diameter is desirable after the measuring device (Simon and Korom [8]). The most commonly used methods are described in the following sections.

3.1 Orifice Flow Meter

It should be noted that the orifice flow meter is not considered suitable for wastewater flow measurement, due to the solids content of the flow. An orifice is a cylindrical or prismatic opening through which fluid flows.

The size of the opening is accurately calculated and bored to produce the required differential pressure for the specified flow condition (see Figure 15). Usually pressures and differential pressures are determined using one of the above, discussed instruments. Most of commercially available orifice meters are supplied with a calibration chart.

Because of its simplicity, low cost, ease of installation, and high accuracy, orifice plates are commonly used to determine the flow rates based on the differential pressure readings, and in order to measure flow rates accurately it is necessary that the interior of the pipe be smooth and round. Two main types of orifices are available:

1. Thin plate orifice,
2. Sharp-edged orifice.

Orifices can be made of various materials with different corrosion-resistant characteristics and can be assembled in two ways:

1. The orifice is completely welded in place and cannot be removed. Commercially available orifices can support up to 4137 kpa pressure and 371 C° operating condition (Badger Meter [7]).
2. The orifice plate is retained in place with flanges.

Flow estimation is based on the following equation:

$$Q = KA\sqrt{(2gh)}$$

Where:

$$\begin{aligned} k &= \text{flow coefficient} \\ h &= h_1 - h_2 \text{ pressure head (m)} \\ g &= 9.81(\text{m/s}^2) \end{aligned}$$

3.2 Venturi Flow Meter

Venturi meters are used to measure the flow in closed conduits, and they consist of:

1. The inlet cone, where the diameter of the conduit is gradually reduced.
2. The throat or constricted section; in standard meters the throat has a size range of $1/5 D - 3/4 D$ the diameter of the pipe, and its length is equal to its diameter.
3. The outlet cone, in which the diameter increases gradually to that of the pipe in which the meter is inserted.

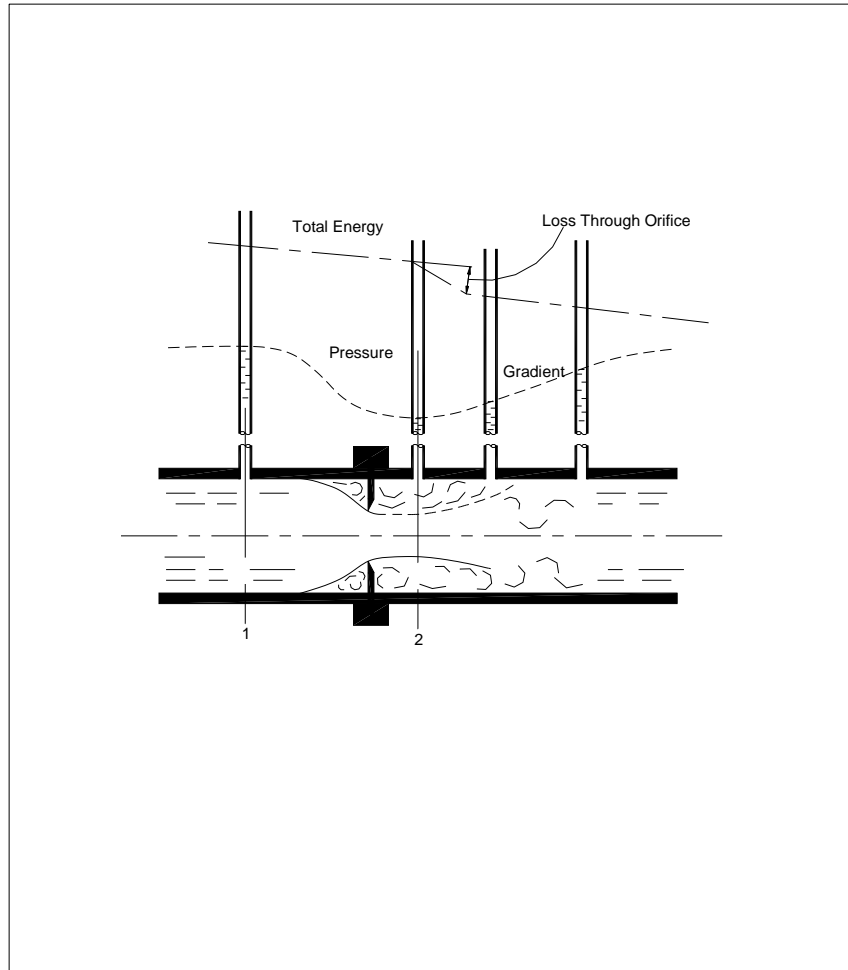

Figure 13. Continuity Equation

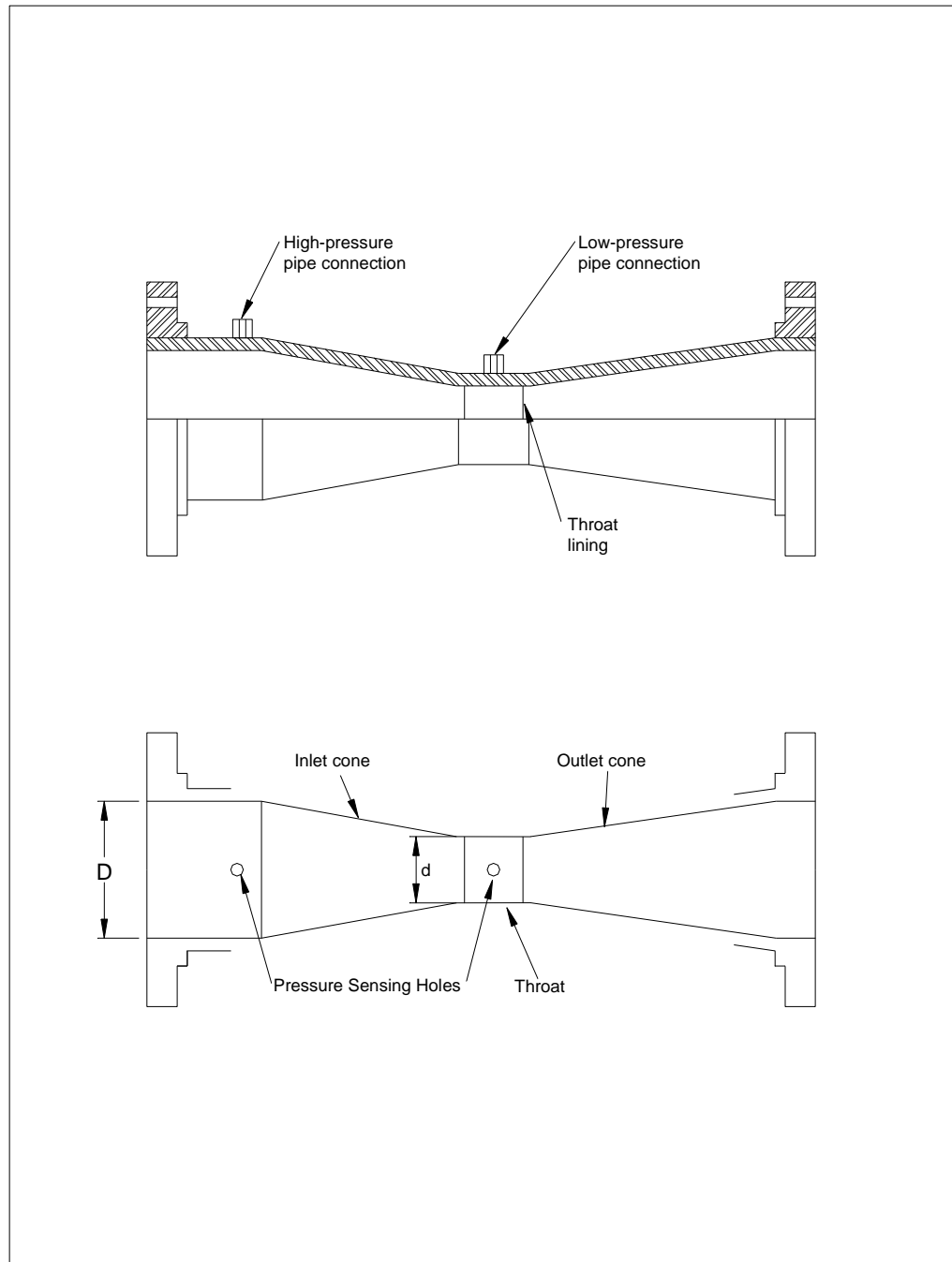

Figure 14. Typical Venturi meter

A Venturi meter operates on the same principle as the orifice but with a much smaller head loss (see Figure 14). The flow rates through the meter are determined based on the difference between pressures indicated at the inlet and at the throat of the meter, and the equation used to determine the discharge is:

$$Q = CA\sqrt{2gh}$$

Where:

A = Area at throat of meter (m²)

H = h₁ - h₂, pressure heads (m)

g = 9.81 m/s²

C = Coefficient of energy losses

Venturi meters need to be cleaned periodically to remove solids, which may clog them, and affect the accuracy of the measurement. A flushing system is necessary for good performance, to keep the pressure sensors from clogging.

3.3 Electromagnetic Flow Meter

The electromagnetic flow meter operation is based on Faraday's law, which simply states that a voltage is generated in any conductive liquid as the liquid moves through a magnetic field. This voltage is sensed by electrodes embedded in the sensor, and is transmitted to the meter. The voltage is proportional to the velocity of the conductive liquid (conductor).

Electrodes are made of various materials (e.g. stainless steel) depending on the fluid characteristics in which they are applied, and can be easily fouled by floating materials, oil, and grease, thus requiring frequent cleaning. The key disadvantages of electromagnetic flow meters are the high cost when used in large pipe diameters, high operational costs and maintenance, and their complex installation.

Electromagnetic flow meters for wastewater applications range in size from 15 - 2200 mm with a claimed accuracy in the range of +/- 0.15% under ideal conditions.

The following points should be taken into consideration when choosing and installing electromagnetic flow meters:

The meter and transmitter should be located a minimum of 6m (20ft) from EMI (Electro-Magnetic-Interference) generating machinery;

The installation should be downstream of a pump, and upstream of control valves (100 hp or larger);

The meter and the transmitter should not be installed after a double change in plane (i.e. elbows, or a tee and an elbow).

3.4 Doppler Flow Meter

A Doppler flow meter (a type of area-velocity meter) operates by emitting into the flow ultrasonic waves of known frequency and duration from a transmitter located either on the channel invert or on the outside of the conduit in the 3 or 9 o'clock position. Suspended particles and air bubbles in the flow reflect the emitted waves.

The sensor receives and detects the deflected frequencies, and processes them to determine the average velocity.

The frequencies are proportional to the velocity of the points in the liquid flow at which the reflection occurred. The measurement accuracy is a function of the percent sound reflectors (solids and bubbles), their sizes, distribution, and the flow meter design features. For the appropriate selection and installation of this type of flow meter the following points should be considered:

Sonic reflectors (i.e. suspended solids, etc.) representative of fluid velocity must be present in the liquid;

The pipe should have a uniform cross section without abrupt changes in direction for a minimum of 10 pipe diameters upstream and 5 diameters downstream;

Manufacturers' minimum distance requirements should be met;

If transducers are to be mounted on the outside, the pipe material should allow the penetration of the ultrasonic signal.

3.5 Pressure Transducers

Transducers are devices that produce an electrical signal proportional to some physical phenomenon (pressure, temperature, humidity, flow, etc.). The main element of the pressure transducer is the sensing element, consisting of a membrane (diaphragm) which is able to respond to the applied process pressure and static pressure. The diaphragm is deformed by the pressure differential applied on it, and the deflection is transmitted to a gauge or meter, either electrically or magnetically. The change in measured voltage flowing through the electric strain gauge is proportional to the pressure of the fluid on the diaphragm.

The diaphragm is usually made of stainless steel, copper or silicon. Stainless steel diaphragms are well suited for high pressures and have superior corrosion resistance. Silicone diaphragms have greater accuracy, but are limited to use with lower pressure transducers.

Pressure transducers can be classified as:

- Absolute pressure transducers; measure pressure in relation to zero pressure (a vacuum on one side of the diaphragm) (PSIA).
- Differential transducers; measure pressure difference between two points (PSID).
- Gage pressure transducers; a form of differential pressure measurement, which takes atmospheric pressure as a reference (PSIG).

3.5.1. Selection of Pressure Transducers

The following are the main considerations in selecting pressure transducers:

- The pressure requirements of the system, which means the normal working pressures should be below the maximum used range of the transducer. (As a guideline, select a transducer with a range of 125% of the normal working pressure and refer to the pressure strain and force (OMEGA Technologies Company [9]);
- Compatibility of the transducer with the fluid;
- The maximum system temperature should not exceed the stated maximum operating temperature of the transducer;
- Durability within the pressure environment.

Commercially available pressure transducers are able to measure pressures in a range of 0-2000 PSIG in operating temperatures (-55 - +125C°) with an accuracy range of * 0.1 - 1.5% (OMEGA Technologies Company [9]).

3.6 Area Velocity

The Area-Velocity method consists of measuring both cross-sectional area of a flow stream at a certain point, and the average velocity of the flow in that cross section. The Area-velocity method can be used either with open channel or closed channel flows. In addition to measuring flow under free conditions it can also be used to measure flow under submerged, full pipe, and surcharged flow conditions. This method does not require the installation of a weir or flume and it is used usually for temporary flow monitoring applications such as inflow and infiltration studies.

The flow rate is calculated by multiplying the area of the flow by its average velocity $Q=A \times V$ (Figure15). The Area-Velocity method requires two separate measurements, one to determine the flow depth and the other the average velocity of the section. This method can be implemented in two ways: 1) The depth and velocity are measured manually and used to determine the area and flow rates in a particular time. 2) An Area-Velocity flow meter used to measure the liquid level and velocity and automatically calculate the flow rate.

4. Flow Recorders

Flow recorders (applicable to both open channel and full pipe flow meters) can be distinguished based on the method by which flow data is managed and stored.

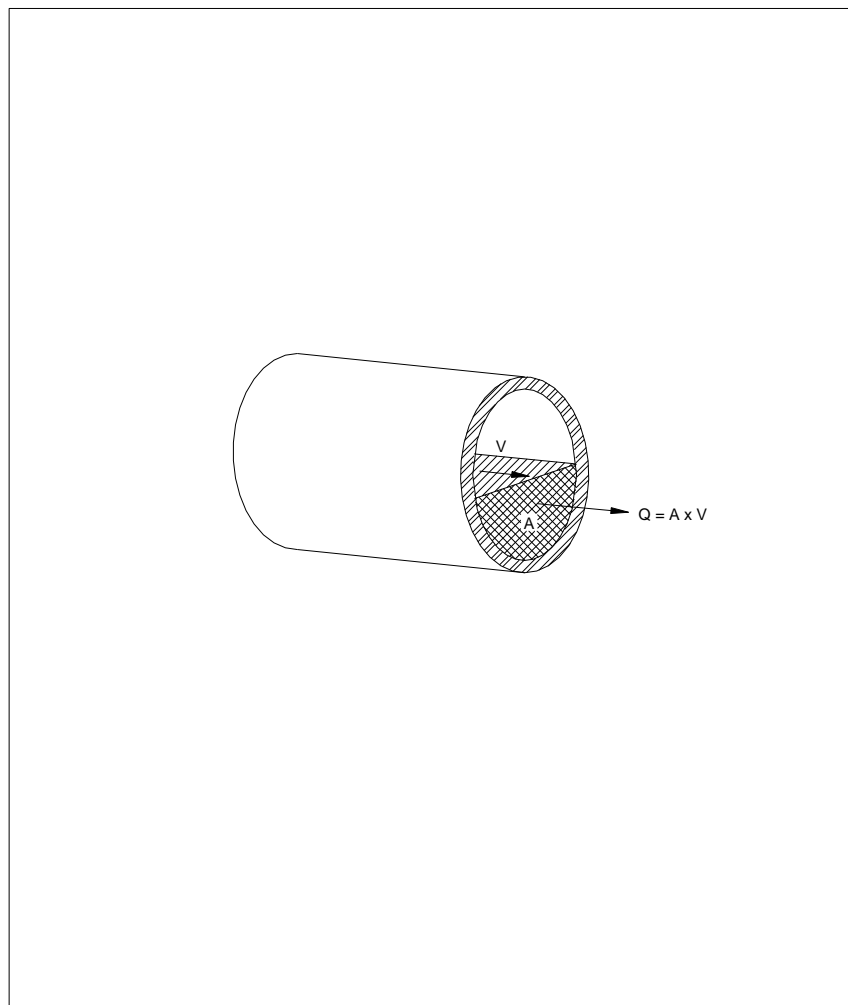

Figure 15. Area - Velocity Method (Continuity Equation)

4.1 Flow Transmitters

Flow transmitters are used to calculate the flow based on secondary device level information and the primary device flow equation, and then transfer the flow data to other recording instruments, and computers. These devices also usually include a digital display, which can be set to display both flow and liquid level information. Flow transmitters usually output an analog signal (e.g. 4 to 20 mA), but may also produce a digital output (e.g. RS-232 serial output). Most data recorders and display devices will accept an analog signal, but this should be confirmed with the manufacturer. Many transmitters also incorporate limited data logging features.

4.2 Chart Recorders and Data Loggers

Chart recorders offer immediate visual information, whereas data loggers usually allow the data to be stored in memory, and downloaded to a central computer for later data analysis.

Recorders and data loggers are used to record and store both analog and digital data by writing either an analog or digital trace, or actual numeric values, onto paper for a specific period of time. These devices can be programmed to take input directly from the secondary measuring device and convert the information to flow.

The resulting recording is a permanent analog and/or digital printout. Most of today's recorders are able to record multiple variables such as pH, temperature, flow, velocity, etc. There are many types of recorders such as:

- Flatbed recorder; used where portability is a major factor (e.g. laboratory, field, etc.).
- Vertical recorder; used where permanent installation is required
- (e.g. industrial applications).
- X-Y recorder; used where two input signals need to be compared.
- (e.g. recording temperature vs pressure instead of recording temperature vs time).
- Circular chart recorders; most often used in remote locations, computer rooms for a permanent record over a long time of period, generally use wider chart paper (up to 250mm). Their key advantage lies in the ability to readily view the flow records to assist in operating tasks without having to analyze the recorded data. Charts are available to record for periods of 24 hours, 7 days, 30 days and 4 months.

Most of today's recorders and data loggers use a 4-20 mA input circuit (industry standard) and can interface with other devices to record other parameters. Stored data can be downloaded to a computer through either a RS-232 serial port or via a standard or wireless modem. Depending on the type of input signal, recorders can have plug-in modules where the type of input signal can be changed by simply unplugging the old module and plugging in the new input module, or integrally selectable inputs where a selection of the desired input type for each channel is possible.

4.2.1 Charts vs Data Loggers

The major difference between a data logger and a recorder is the way the data is recorded, stored and analyzed. In addition to a chart's capability to offer immediate visual information, charts provide a continuous trend recording. Most recorders accept an input and compare it to the chart's full scale value, which makes it easy to visually analyse the data (e.g. if the recorder has 1 volt full scale, then an input of 0.5 volts will move the recording pen to 0.5/1 or 50% of the distance across the recording width). Given that most small wastewater treatment plants do not have a central computer station; the use of a chart recorder is still considered one of the best approaches in assisting the operator in daily operations.

Most data loggers usually store the data in their own built in memory, to be retrieved at a later time for further data analysis.

To retrieve and analyse the stored data, other external and peripheral equipment are required such as a standard or wireless modem, central computer and a printer if a hard copy is needed.

4.2.2 Selection Criteria of Recorders and Data Loggers

When choosing a recorder or a data logger the following should be taken into consideration:

- Determine the type or types of the input signals that need to be measured;
- Determine how many inputs need to be fed to the device at one time, this will determine the number of channels needed;
- Determine the type of chart needed based on the period and accuracy of the recording;
- Determine the type of recorder and data logger based on factors such as portability, permanent installation, application, data transfer, recording intervals, etc.

5. Sources of Further Information

1. Kirkpatrick, George A. and Shelley, Philip E. Sewer Flow Measurement – A State-of-the Art Assessment. EPA Environmental Protection Technology Series, EPA-600/2-75-027, 1975.
2. Grant, Douglas M. and Dawson, Brian D. “ISCO”. Open Channel Flow Measurement Handbook, Fifth Edition.
3. Pratt, E.A. “Another Proportional-Flow Weir: Sutro Weir” Engineering News, Vol. 72 No. 9 (August 27, 1914): 462-463.
4. Irwin, Lafayette K. “Proceedings of the Symposium on Flow Measurement in Open Channels and Closed Conduits.” Volume 1. Institute for Basic Standards, Washington.
5. MagneTek Controls. “Liquid Level Control and Gauging Systems”.
6. Milltronics Process Measurements. “Ultrasonic Transducers”.
7. Badger Meter. “Flow meters and Instrumentation”. Industrial Division.
8. Simon, Andrew L. and Korom, Scott F. “Hydraulics” (Fourth Edition). Prentice Hall.
9. OMEGA Technologies Company. “The pressure strain and force handbook”.

6. Revision History

- February 28, 2001: Re-publication. Figures enhanced by Bert Brazier. Appendix 1 added.
- March 2000: NovaTec replaced figures since CAD format was not compatible with Ministry software.
- 1999: Draft manual prepared by NovaTec Consultants Inc. under contract to the Ministry (NovaTec Project 1231.14). Method vetted and approved by BCLQAAC.

APPENDIX 1 Effluent Flow Measurement Checklist

A. General Information

- Type of flow measurement device: _____
- Make/model: _____
 - Date of installation: _____
 - Installation according to manufacturer's specification **Yes** **No**

 - Comments: (Attach manufacturer's instructions) _____

B. Measuring Devices

- | | Yes | No |
|---|------------|-----------|
| 1. Weirs | | |
| - Is the weir horizontal? (Use a level to check) | _____ | _____ |
| - Is the weir knife-edged? (For plates thicker than 3.2 mm) | _____ | _____ |
| - Is head measurement device located at a point located greater than 2.5 H upstream of the crest of the weir? | _____ | _____ |
| - Is the device free from hydraulic disturbance? | _____ | _____ |
| - Are there any leaks? | _____ | _____ |
| 2. Parshall Flumes | | |
| - Is the upstream flow head measured at a point located at 2/3 of the length along the converging section upstream of the throat (narrowed section) of the flume? | _____ | _____ |
| - Are there any leaks? | _____ | _____ |
| 3. Orifice, Venturi and Magnetic Flow Meters | Yes | No |
| - Is the meter installed in a section of pipe that ensures full-pipe flow? | _____ | _____ |
| - How was this verified? _____

_____ | | |

C. Maintenance

- | | Yes | No |
|--|------------|-----------|
| - Is the meter installed in a section of pipe that ensures full-pipe flow? | ___ | ___ |
| - How was this verified? _____

_____ | | |

D. Calibration

Frequency of calibration of measuring system: _____
(Should be at least annually)

- Method of calibration: _____
(Attach latest calibration calculations)
- Accuracy ± _____ %

- | | Yes | No |
|---|------------|-----------|
| - Is recorder service required regularly? | ___ | ___ |
| - Is gauge zeroed? | ___ | ___ |
| - Comments: _____

_____ | | |

Inspector: _____

Date: _____