

**ELECTRICAL MAINTENANCE SERVICE AGREEMENT
LOWER MAINLAND EAST ELECTRICAL SERVICE AREA**

THIS AGREEMENT dated for reference the 1st day of September, 2021

BETWEEN:

HER MAJESTY THE QUEEN IN RIGHT OF THE PROVINCE OF BRITISH COLUMBIA,
as represented by the Minister Responsible for the Transportation Act (the "Province")

AND:

@@ Name, having an office at
@@Address (the "Contractor")

TABLE OF CONTENTS

1.	DEFINITIONS.....	1
2.	REPRESENTATIONS AND WARRANTIES	7
3.	APPOINTMENT, TERM AND RENEWAL OF AGREEMENT	10
4.	LEGAL RELATIONSHIP – INDEPENDENT CONTRACTOR	12
5.	TAX VERIFICATION.....	12
6.	PRIME CONTRACTOR	12
7.	SERVICES & WARRANTY.....	13
8.	CHANGES TO INVENTORY WITHIN ELECTRICAL SERVICE AREA	13
9.	CHANGES TO ROUTINE MAINTENANCE SERVICES.....	14
10.	PROVINCIAL MATERIAL	16
11.	INSURANCE AND INDEMNITY	16
12.	BONDS.....	18
13.	CONTRACTOR'S COVENANTS	18
14.	ANNUAL PRICE AND FEES	21
15.	DAMAGE TO GOVERNMENT PROPERTY	23
16.	STOLEN WIRE.....	24
17.	ELECTRICAL PERMITS.....	25
18.	ASSIGNMENT, SUBCONTRACTING	25
19.	RECORDS AND REPORTS.....	26
20.	FINANCIAL AUDIT	29
21.	QUALITY	30
22.	DEFAULT AND REMEDIES	31
23.	DISPUTE RESOLUTION.....	33
24.	FORCE MAJEURE	33
25.	NOTICES.....	35
26.	JOINT AND SEVERAL LIABILITY AND GUARANTEE RE JOINT VENTURES.....	35
27.	MISCELLANEOUS	35
28.	INTERPRETATION	37
29.	COUNTERPARTS.....	39

LIST OF SCHEDULES

Schedule 1	Specifications
Schedule 2	Local Area Specifications
Schedule 3	Electrical Service Area (Map Reference)
Schedule 4	Inventory
Schedule 5	Fee
Schedule 6	Cost for Changes to Inventory
Schedule 7	Annual Adjustment Process
Schedule 8	Additional Services
Schedule 9	Prime Contractor Designation
Schedule 10	Dispute Resolution Protocol
Schedule 11	Equipment Fleet Operations Policy
Schedule 12	Repeater System
Schedule 13	Provincial Material List
Schedule 14	Bonds
Schedule 15	Insurance
Schedule 16	Insurance & Securities (Renewal Term)
Schedule 17	Privacy Protection
Schedule 18	Contractor Details
Schedule 19	Tax Verification

**ELECTRICAL MAINTENANCE SERVICE AGREEMENT
LOWER MAINLAND EAST ELECTRICAL SERVICE AREA**

THIS AGREEMENT dated for reference the 1st day of September, 2021.

BETWEEN:

HER MAJESTY THE QUEEN IN RIGHT OF THE PROVINCE OF BRITISH COLUMBIA, as represented by the Minister Responsible for the Transportation Act (the "Province")

AND:

@@ Name, having an office at (the "Contractor")

(together, "the Parties")

WHEREAS:

- A. The Province has agreed to appoint and retain the Contractor to provide certain electrical maintenance services; and
- B. The Contractor has agreed to provide such services for the Province on the terms of this Agreement.

NOW THEREFOR in consideration of the premises and the covenants, agreements, representations, warranties and payments hereinafter contained the Parties agree as follows:

1. DEFINITIONS

1.1 In this Agreement, unless the context otherwise requires:

- (a) **"Additional Services"** has the same meaning in Schedule 8 ("Additional Services");
- (b) **"Adjusted Annual Price"** means the annual sum payable by the Province to the Contractor, exclusive of GST and inclusive of all other applicable taxes, duties and other charges, in consideration for the provision of Routine Maintenance Services during a Contract Year subsequent to the First Contract Year, as may be amended from time to time in accordance with this Agreement including but not limited to changes to Services, changes to Inventory or through the Annual Adjustment Process;
- (c) **"Agreement"** or **"Electrical Maintenance Service Agreement"** means this agreement;
- (d) **"Anniversary Date"** means September 1, 2022 and each anniversary thereafter;
- (e) **"Annual Adjustment Process"** means the annual adjustment process described in Schedule 7 ("Annual Adjustment Process");
- (f) **"Annual Price"** means the price for the First Contract Year, the Base Annual Price, or the Adjusted Annual Price as the context requires. Expressed for a 365 day time period or 366 day time period for a leap year (exclusive of GST and inclusive of all other applicable taxes, duties and other charges) for a particular Contract Year;
- (g) **"Appropriation"** has the same in section 1 of the FAA;
- (h) **"Arbitration"** has the same meaning and procedure in Schedule 10 ("Dispute Resolution Protocol");
- (i) **"Base Annual Price"** means the price of \$@@ (exclusive of GST and inclusive of all other

applicable taxes, duties and other charges) submitted by the Contractor, pursuant to the Price Proposal inclusive of any changes pursuant to Section 8.6, and accepted by the Province for the provision of Routine Maintenance Services for 365 days of the Term or 366 days of the Term for a leap year;

- (j) **"Base Location"** means the locations within the Electrical Service Area in which the Contractor must have personnel presence capable of carrying out the Services required under the Specifications for each municipality listed herein. The base locations for the various electrical service areas are as follows:
- Vancouver Island Service Area - Greater Nanaimo Area and the Greater Victoria Area;
 - Lower Mainland West Service Area - Metro Vancouver Area
 - Lower Mainland East Service Area - Metro Vancouver or Fraser Valley Area
 - Southern Interior Service Area - Kamloops, Kelowna, and Nelson; and
 - Northern Region Service Area - Prince George, Terrace, and Fort St. John;
- (k) **"BCTFA"** means the British Columbia Transportation Financing Authority, an agent of the Province continued under the *Transportation Act*;
- (l) **"Bonds"** means the performance and the labour and material payment bonds in the format specified in Schedule 14 ("Bonds"), with the "Bond Amount" in each such bond being \$1,230,000;
- (m) **"Change Order"** means a written order by the Province requiring the Contractor to perform a change to Routine Maintenance Services pursuant to Article 9;
- (n) **"Claim"** means any order, demand, suit, action, prosecution, summons, commencement of legal proceedings, charge, investigation, petition or proceedings from any person or Government Authority, settlement discussions or alternative dispute resolution mechanisms and any termination, suspension, abandonment, discontinuance, appeal or review thereof;
- (o) **"CMC" or "Chargeable Maintenance Claim"** means Damage to Government Property Claim;
- (p) **"Commencement Date"** means September 1, 2021;
- (q) **"Contract Month"** means a calendar month;
- (r) **"Contract Year"** means a period of 12 consecutive months during the Term, commencing on the Commencement Date and continuing on each Anniversary Date for 12 consecutive calendar months thereafter to and including the Expiry Date;
- (s) **"Contractor"** means **@@Company (Partnership) Name**, its directors and officers, partners, agents, employees, contractors, successors and assigns;
- (t) **"Contractor's Quality Plan"** means the quality plan developed by the Contractor, and delivered pursuant to Section 18.1 of the RFP and as amended from time to time in accordance with Article 21;
- (u) **"Controlled Person(s)"** means the Contractor's representatives, employees, agents, directors, officers, management, shareholders, suppliers, Subcontractors (and their employees and representatives), hired equipment owners or operators (and their employees and representatives) and any other person or entity retained to perform the Services, along with the Contractor's partners and other joint venture members, if applicable;

- (v) **"Cost Plus Rates"** means the rates described in Schedule 8 ("Additional Services"), Appendix 1;
- (w) **"Cost Schedule"** means the schedule of costs with respect to a change(s) in Inventory, as set out in Schedule 6 ("Cost for Changes to Inventory");
- (x) **"CVSA"** means the *Commercial Vehicles Safety Alliance*;
- (y) **"Daily Cost"** means in respect of a particular Contract Year, the Annual Price for that Contract Year divided by the total number of days in that Contract Year (representing the per diem costs to the Province of the Contractor providing the Routine Maintenance Services during that Contract Year);
- (z) **"Damage to Government Property"** means damage to the electrical infrastructure caused by motor vehicles, acts of vandalism, theft, weather events or other acts of God, or other acts of a third party;
- (aa) **"Damage to Government Property Claim"** the claim process for recovering the cost of repairing Damage to Government Property. For clarity, incidences of Stolen Wire do not form part of Damage to Government Property or damage to government property claims;
- (bb) **"Dispute Resolution Protocol"** means the dispute resolution protocol attached as Schedule 10 ("Dispute Resolution Protocol");
- (cc) **"DriveBC"** means the traveler information system website at <http://www.drivebc.ca>
- (dd) **"Electrical Service Area"** means the area described in Schedule 3 ("Electrical Service Area (Map Reference)");
- (ee) **"Equipment Fleet Operations Policy"** means the standard for the lighting and markings of the Contractor's equipment fleets as described in Schedule 11 ("Equipment Fleet Operations Policy");
- (ff) **"Event of Default"** means any event described in Section 22.1;
- (gg) **"Expiry Date"** means August 31, 2026, or August 31, 2031 of the renewal term, as the case may be;
- (hh) **"FAA"** means the *Financial Administration Act*, R.S.B.C. 1996, c.138;
- (ii) **"Fee Schedule"** means the schedule of fees for the provision of Services attached as Schedule 5 ("Fee Schedule");
- (jj) **"First Contract Year"** means September 1, 2021 to August 31, 2022;
- (kk) **"Force Majeure"** means:
 - (i) acts of God, wars (declared or undeclared), revolutions, riots, insurrections, lockouts, or strikes (including illegal work stoppages) by third parties including lockouts or strikes by or of the Contractor's or a Controlled Person's employees, provided that any such event is a major disabling event or circumstance in relation to the normal operations of the party directly affected as a whole, which is beyond the reasonable control of that party and results in a material delay, interruption or failure by that party in carrying out its duties, covenants or obligations under this Agreement, provided always that lack of money, financing or credit to resolve such contingencies will not be deemed an event of Force Majeure; and

- (ii) for the purposes of Section 24.2, the failure by the Contractor to obtain or maintain in force commercial general liability insurance as described in Article 11, provided that:
 - (A) the Contractor has used its best efforts to obtain the insurance;
 - (B) the Contractor's failure to retain the insurance, that is in place, is not due to the Contractor's breach of the terms of an existing insurance contract placed in compliance with Article 11;
 - (C) the Contractor's failure to obtain the insurance does not occur as a result of the Contractor's lack of money, financing or credit or due to the Contractor's performance record under this Agreement; and
 - (D) the Province and the Contractor have not resolved the issue of the Contractor's failure to obtain insurance in a manner that is acceptable to both parties.
- (ll) **"Government Authority"** means a federal, provincial, regional, municipal or local government or subdivision thereof, including an entity or person exercising executive, legislative, regulatory or administrative functions of, or pertaining to, any such government or subdivision;
- (mm) **"GPS Coordinates"** means the expression of latitude and longitude in decimal degrees to six decimal places of precision;
- (nn) **"Government Property"** means government property, whether Inventory or otherwise;
- (oo) **"GST"** means the Goods and Services Tax imposed under the *Excise Tax Act*, R.S. 1985 c. E-15 as amended from time to time, and the regulations prescribed thereunder;
- (pp) **"Hardening"** means the installation of steel plate junction boxes, the burial of Teck cables, or any other method to help prevent or reduce the risk of further wire or battery theft as pre-approved by the Province;
- (qq) **"Highway Maintenance Contractor"** means the person who has entered into a contract with the Province to provide highway maintenance services to the Province in the relevant Highway Maintenance Service Area;
- (rr) **"Highway Maintenance Service Area"** means one of the Ministry's service areas for highway maintenance falling wholly or partly within the Electrical Service Area;
- (ss) **"Highways"** means all highways, as defined in the *Transportation Act*, S.B.C. 2004, c.44, within the Electrical Service Area that are under the administration of the Province, or highways that are by arrangement maintained by the Province, and includes:
 - (i) all ancillary works, excavations, embankments and improvements reasonably related to the operation of the highways;
 - (ii) all licenses, rights of way and easements ancillary to highways existing as of the date of this Agreement as determined by reference to the records of the Province; and
 - (iii) any highways that are vested in any Municipality pursuant to the *Local Government Act*, R.S.B.C. 1996 c.323 and *Community Charter*, S.B.C. 2003, c.26, at the discretion of the Province and on written notice from the Province to the Contractor.

- (tt) **"Inventory"** means all of the number and type of electrical devices contained within the Electrical Service Area as set out in Schedule 4 ("Inventory") and as may be revised from time to time in accordance with the provisions of this Agreement;
- (uu) **"LED"** means light emitting diode;
- (vv) **"LED Cap"** has the same meaning in Section 14.10;
- (ww) **"Local Area Specifications"** means those specifications in Schedule 2 ("Local Area Specifications") for Routine Maintenance Services as may be amended by the Province from time to time by written notice to the Contractor;
- (xx) **"Maintenance Contractor(s)"** means both the electrical maintenance contractors and the Highway Maintenance Contractors or one of them as the context requires;
- (yy) **"Ministry" OR "Minister"** means the Province;
- (zz) **"Ministry Representative"** means the Province's representative, as notified in writing to the Contractor from time to time;
- (aaa) **"MVAR"** means the *Motor Vehicle Act Regulations*, B.C. Reg. 26/58;
- (bbb) **"Non-Conformance Report"** means those reports issued in writing by the Province which document the Contractor's failure to comply with the Contractor's covenants in this Agreement;
- (ccc) **"NSC"** means the *National Safety Code* as defined in British Columbia MVAR Division 37;
- (ddd) **"OHS Regulation"** means the British Columbia Regulation 296/97 entitled *"Occupational Health and Safety Regulation"*, as it may be amended from time to time;
- (eee) **"Price Adjustment Factor"** has the same meaning in Schedule 7 ("Annual Adjustment Process");
- (fff) **"Prime Contractor"** means the "prime contractor" as defined in the *Workers Compensation Act*, R.S.B.C. 1996, c.492;
- (ggg) **"Proposal"** means the proposal to perform the Services delivered by the Contractor to the Province in response to the RFP;
- (hhh) **"Province"** means Her Majesty the Queen in right of the Province of British Columbia, as represented by the Minister of Transportation and Infrastructure, her agents, servants, employees and contractors;
- (iii) **"Provincial Material"** means all materials, equipment, components, supplies, tools, manuals, databases and reports that are provided by or on behalf of the Province to the Contractor prior to or during the Term as listed in Schedule 13 ("Provincial Material List") and as updated by the Contractor as described in Article 10, and Provincial Material will remain at all times the property of the Province;
- (jjj) **"Provincial Quality Plan"** means the Electrical Quality Plan Manual available on the Province's website;
- (kkk) **"Repeater System"** means the repeater system described in Schedule 12 ("Repeater System");
- (III) **"Recovered Amount(s)"** means amount(s) recovered by the Province in respect of a Damage to Government Property Claim respecting Damage to Government Property as referred to in Article 15;

- (mmm) **"Revised Daily Cost"** means in respect of a particular Contract Year, the revised daily cost to the Province of the Contractor providing the Routine Maintenance Services during that Contract Year as calculated from time to time by the Province pursuant to Article 8;
- (nnn) **"RFP"** means the document package titled "Electrical Maintenance Service Agreement for Lower Mainland East Electrical Service Area – Request for Proposals # ELEC-SALME-R3 and published by the Province (for the Services for this Electrical Service Area) on the electronic procurement system maintained by the Province (BC Bid);
- (ooo) **"Routine Maintenance Services"** means those routine electrical maintenance services described as such in Schedule 1 ("Specifications") and Schedule 2 ("Local Area Specifications") which will be provided with respect to the Inventory and all work except Additional Services;
- (ppp) **"Safety Program"** means an occupational health and safety program in compliance with the requirements of and as certified by the Workers Compensation Board;
- (qqq) **"Services"** means the provision of all labour, materials and equipment for the purpose of providing the electrical maintenance services described as such in the Specifications in Schedule 1 ("Specifications") and Schedule 2 ("Local Area Specifications") as those maintenance services may be changed from time to time in accordance with Article 9, and includes Additional Services and Routine Maintenance Services;
- (rrr) **"Specifications"** means those specifications in Schedule 1 ("Specifications") and Schedule 2 ("Local Area Specifications") for Routine Maintenance Services as may be amended by the Province from time to time by written notice to the Contractor;
- (sss) **"Stolen Wire"** means wire stolen by third parties from the electrical infrastructure;
- (ttt) **"Subcontractor(s)"** means the Contractor's subcontractors and sub-subcontractors and their servants, employees, agents, management, shareholders, directors, officers and suppliers;
- (uuu) **"Tax Verification Letter"** means a letter issued by the Province of British Columbia's Ministry of Finance verifying that the Contractor meets its applicable B.C. corporate income tax filing obligations and provincial sales tax (PST) filing and payment obligations;
- (vvv) **"Term"** means a period of five (5) years and one renewal period of a further five (5) years at the Province's discretion, as described in Section 3.4 and subject to earlier termination pursuant to Article 22;
- (www) **"TMCBC"** means the Transportation Management Centre of British Columbia;
- (xxx) **"UPS"** means Uninterruptible Power Supply;
- (yyy) **"Valid"** means that the Tax Verification Letter's period of validity, as indicated on the Tax Verification Letter, has not ended.
- (zzz) **"Wire Theft Cap"** has the same meaning in Article 16;
- (aaaa) **"Work Plan"** means a work plan for upgrading aging Inventory set out in Sections 14.11 - 14.14;
- (bbbb) **"Workers Compensation Act"** means the *Workers Compensation Act*, R.S.B.C. 1996, c. 492, as amended from time to time, and the regulations prescribed thereunder; and
- (cccc) **"Working Day"** and **"Work Day"** means any day which is not a Saturday, a Sunday or a day on which Provincial government offices are closed in British Columbia.

2. REPRESENTATIONS AND WARRANTIES

2.1 The Contractor represents and warrants to the Province, with the knowledge and intent that the Province shall rely thereon in entering into this Agreement, that on the execution of this Agreement and at all times thereafter during the Term that:

- (a) it is an entity, duly organized and validly existing under the laws of British Columbia, Canada, or under the laws of any other province or state in which case the Contractor is registered extra-provincially in British Columbia;
- (b) it is in good standing with respect to the filing of annual reports according to the records of the Office of the Registrar of Companies in British Columbia, Canada, if applicable;
- (c) it has the full authority, power and capacity to enter into and carry out the transactions contemplated by, and to observe, perform and comply with the terms of this Agreement and all other documents, instruments and agreements required to be executed and delivered by the Contractor pursuant to or in connection with this Agreement;
- (d) all necessary proceedings and actions have been taken and done, and approvals obtained, to authorize the execution and delivery by the Contractor of this Agreement and all of the other documents, instruments or agreements referred to in subsection 2.1(c);
- (e) this Agreement and all of the other documents, instruments or agreements referred to in subsection 2.1(c) have been legally and properly executed by the Contractor and are valid, subsisting and legally binding upon and enforceable against the Contractor in accordance with their respective terms;
- (f) all information, statements, documents and reports furnished or submitted to the Province in connection with this Agreement and all of the other documents, instruments or agreements referred to in subsection 2.1(c) are true, accurate and correct in all respects and remain correct and accurate in all respects and do not omit any information required to make such statements, representations and information not misleading when taken as a whole;
- (g) it has no knowledge of any fact that might, or might be foreseen to, materially adversely affect its properties, assets, condition (financial or otherwise), business operations or its ability to fulfill its obligations under this Agreement and all of the other documents, instruments or agreements referred to in subsection 2.1(c) including its obligations to observe, perform and comply with the terms and conditions thereof;
- (h) the execution and delivery of this Agreement and all of the other documents, instruments or agreements referred to in subsection 2.1(c), the observance, performance and compliance with the terms and conditions thereof, and the consummation of the transactions contemplated thereunder, do not and shall not conflict with, result in a breach of, constitute a default under, accelerate or permit the acceleration of any indebtedness or performance under, or require any consent, authorization or approval under (whether with notice or lapse of time or both):
 - (i) any statute, regulation or bylaw (including, but not limited to, those of Canada or the Province of British Columbia) applicable to or binding on it;
 - (ii) its constating documents (including, but not limited to, any memorandum, notice of articles, articles or bylaws); or
 - (iii) any contract, instrument or agreement to which it is a party or any other document which is binding upon it or any of its assets, including, but not limited to, any terms,

provisions or conditions of, any indenture, mortgage, deed of trust, agreement, security agreement, license, franchise, certificate, consent, permit, authority, judgment, decree, order, rule or regulation of any court or administrative body;

- (i) the authorized share capital of the Contractor, if applicable, is as disclosed in Schedule 18 ("Contractor Details");
- (j) the effective control and the direct, indirect legal or beneficial ownership of all of the authorized, issued and outstanding equity securities or other equity interests of the Contractor are as disclosed in Schedule 18 ("Contractor Details");
- (k) there are no agreements, options or rights of any kind held by any person with respect to any of the voting shares of the Contractor, if applicable, except as disclosed in Schedule 18 ("Contractor Details");
- (l) the Contractor has good safekeeping, marketable title to and possession of all the Contractor's assets, free and clear of all liens, charges or encumbrances except those disclosed in Schedule 18 ("Contractor Details");
- (m) all information completed in Schedule 18 ("Contractor Details") is true and accurate;
- (n) the Contractor is not a party to, and to its knowledge is not threatened with, any litigation or claim that would materially affect its undertaking or financial condition or its ability to fulfil its obligations under this Agreement or any of the other documents, instruments or agreements referred to in subsection 2.1(c), including to observe, perform and comply with the terms thereof;
- (o) there are no liabilities of the Contractor, contingent or otherwise, that are not disclosed or reflected in Schedule 18 ("Contractor Details") herein except those incurred in the ordinary course of its business;
- (p) if the Contractor is a partnership, then the identification of all of the partners of the partnership and their respective interests in the partnership are as disclosed in Schedule 18 ("Contractor Details");
- (q) if the Contractor is a joint venture member, then the identification of all of the joint venture members and each joint venture member's respective interests in the joint venture are as disclosed in Schedule 18 ("Contractor Details");
- (r) if the Contractor is a partnership or a joint venture member and if any of the partners or joint venture members are corporate entities, then:
 - (i) a separate Schedule 18 ("Contractor Details") for each partner or joint venture member discloses the details set forth in subsections 2.1(i) - 2.1(o) of each such partner or joint venture member; and
 - (ii) the representations and warranties required under the other subsections of this Section 2.1 with respect to a Contractor which is a partnership or joint venture member are true for each corporate partner or joint venture member;
- (s) the Contractor has filed all tax, corporate information and other returns, required to be filed by the laws of British Columbia, Canada and any other jurisdiction where the Contractor is required to file such returns, and has complied with all workers compensation legislation and other similar legislation to which it may be subject and has paid all taxes, fees and assessments calculated to be due by the Contractor under those laws;

- (t) no act or proceeding has been taken by or against the Contractor in connection with the dissolution, liquidation, winding up, bankruptcy or reorganization of the Contractor or for the appointment of a trustee, receiver, manager or other administrator of the Contractor or any of its properties or assets nor, to the knowledge of the Contractor, is any such act or proceeding threatened. The Contractor has not sought protection under the *Bankruptcy and Insolvency Act* (Canada) R.S.C. 1985, c. B-3, the *Companies' Creditors Arrangement Act* (Canada) R.S.C. 1985, c.C-36 or other similar legislation;
- (u) the Contractor is not in breach of any statute, regulation or bylaw applicable to the Contractor or its operations or to its performance of its obligations under this Agreement or any of the other documents, instruments or agreements referred to in subsection 2.1(c), including its observance, performance and compliance with the terms thereof;
- (v) the Contractor holds all permits, licenses, consents and authorities issued by any federal, provincial, regional or municipal government or an agency of any of them or by any third parties that are required for the execution by the Contractor of this Agreement and all of the other documents, instruments or agreements referred to in subsection 2.1(c) or the observance, performance and compliance with the terms and conditions thereof or that are necessary in connection with the operations of the Contractor;
- (w) it has no knowledge of any untrue or incorrect representation or assurance, whether verbal or written, given by the Contractor, or any Controlled Persons, to the Province in connection with this Agreement or any of the other documents, instruments or agreements referred to in subsection 2.1(c);
- (x) it has and shall maintain at all times sufficient qualified, trained and experienced staff, and the necessary labour, facilities wherein no less than one maintenance facility shall be in the Service Area, financial, insurance, bonding and security arrangements, materials, appropriate equipment and subcontracting agreements and hired equipment contracts in place and available to fully observe, comply with and perform this Agreement (and any of the other documents, instruments or agreements referred to in subsection 2.1(c)), including the Services and to ensure and enable such observance, compliance and performance of this Agreement (and any other documents, instruments or agreements referred to in subsection 2.1(c)).
- (y) it has independently reviewed, inspected, examined and assessed and is knowledgeable of and has satisfied itself, including by obtaining all necessary information and documentation and professional advice as to:
 - (i) all labour relations issues related to this Agreement;
 - (ii) Highways and their surroundings and conditions, and all existing Inventory and works including works carried out or to be carried out by third parties including other governmental agencies, contractors of the Province and local governments in the Electrical Service Area in, on, over or under such Highways and the Services including all conditions, constraints, restrictions, requirements, factors, contingencies and risks relating or necessary to affecting or that may affect the provision of the Services under and in accordance with this Agreement (or any of the other documents, instruments or agreements referred to in subsection 2.1(c));
 - (iii) the terms of this Agreement (and any of the other documents, instruments or agreements referred to in subsection 2.1(c)), including all notices and instructions issued in connection with the foregoing, if any; and

- (iv) the risks, factors, contingencies, requirements and all other circumstances and conditions, legal and otherwise, which may affect this Agreement (or any of the other documents, instruments or agreements referred to in subsection 2.1(c)), including the Services, and the observance, performance and compliance with the terms and conditions thereof;
 - (z) it has all necessary workers compensation coverage, to cover the performance of the Contractor's obligations under this Agreement;
 - (aa) it is not currently subject to any charge, conviction, ticket, notice of defect or non-compliance, work order, pollution abatement order, pollution prevention order, remediation order or any other order or proceeding under any environmental laws that might reasonably be expected to have a material adverse effect on the performance by the Contractor of its obligations under this Agreement (or any of the other documents, instruments or agreements referred to in subsection 2.1(c));
 - (bb) it has received from the Province and reviewed this Agreement and all Schedules thereto, including but not limited to Schedule 1 ("Specifications");
 - (cc) if more than one person enters into this Agreement as the Contractor, then those persons will be obligated jointly and severally under this Agreement; and
 - (dd) a senior officer of the Contractor will certify and forward to the Province, on each Anniversary Date, that all representations and warranties of the Contractor in this Agreement remain true and correct as if made on the date of such certificate, and that the Contractor is not in default under this Agreement.
- 2.2 All representations, warranties, covenants and agreements made in this Agreement and all certificates and other documents delivered by, or on behalf of, the Contractor are material and will conclusively be deemed to have been relied upon by the Province, notwithstanding any prior or subsequent investigation by the Province.
- 2.3 All statements contained in any certificate or other document delivered by or on behalf of the Contractor to the Province under this Agreement or in connection with any of the transactions contemplated by this Agreement shall be deemed to be representations and warranties of the Contractor under this Agreement.
- 2.4 The provisions of Sections 2.1 - 2.3 will continue in full force and effect notwithstanding the fulfillment by the Contractor of any or all of its obligations under this Agreement or the payment by the Province to the Contractor of any or all of the monies that the Province becomes liable to pay to the Contractor pursuant to this Agreement.

3. APPOINTMENT, TERM AND RENEWAL OF AGREEMENT

- 3.1 The Province retains the Contractor to provide the Services in accordance with the terms of this Agreement.
- 3.2 The Contractor will provide the Services to the Province during the term of this Agreement which term will, notwithstanding the date of execution and delivery of this Agreement, be deemed to commence on the Commencement Date and will end on the Expiry Date or such date of earlier termination as may be established in accordance with Article 22 or any other termination provisions of this Agreement, subject to the possible renewal of the Agreement pursuant to the terms set out in Section 3.4.

- 3.3 The Province's obligations under this Agreement are subject to the following conditions precedent:
- (a) the Contractor fulfilling all obligations which it is required to fulfill under the RFP prior to the Commencement Date despite the Contractor's execution of the Agreement;
 - (b) the Contractor's fulfillment of its obligations included in Section 11.1 and Schedule 15 ("Insurance") on or before the 30th day prior to the Commencement Date; and
 - (c) the Contractor providing written confirmation, no earlier than 90 days but no later than the 30th day prior to the Commencement Date, in a form satisfactory to the Province, that all of the representations and warranties included in Article 2 are true and accurate as of the date of the confirmation.

The foregoing conditions precedent will be satisfied by the Contractor, on written notice to the Province, or waived by the Province, on written notice to the Contractor, to be received on the dates specified for performance, failing which this Agreement will be terminated without prejudice to the rights and remedies of the Province under the RFP process and this Agreement, at law and in equity.

The foregoing conditions precedent are included for the sole benefit of the Province and may be unilaterally waived by the Province at any time prior to the dates specified for satisfaction of the conditions.

- 3.4 The Province will be entitled in its sole discretion to elect to renew the Agreement for a further five (5) Contract Years, such that the Expiry Date will then become five (5) Contract Years after the original Expiry Date. If the Province elects to renew the Agreement, the following provisions will apply:
- (a) the Province will give the Contractor notice of the Province's election to renew the Agreement no later than 12 months prior to the original Expiry Date set out in this Agreement;
 - (b) the Contractor must no later than 10 months prior to the original Expiry Date provide the Province with the following documents as a condition precedent of the renewal, failing which the Province will have the option of revoking the notice of renewal with the result that the Term of the Agreement will end on the original Expiry Date:
 - (i) a consent of surety in the form attached in Schedule 16 ("Insurance & Securities (Renewal Term)"); and
 - (ii) an undertaking to provide liability insurance in the form attached in Schedule 16 ("Insurance & Securities (Renewal Term)") (with the Province notifying the Contractor of the amount of insurance to be set out in the undertaking no later than 12 months prior to the original Expiry Date);
 - (c) the consent of surety by an alternate surety for the renewal term of this Agreement, and the undertaking to provide liability insurance documents to be submitted by the Contractor under subsection 3.4(b) shall be in the same format as set out in Schedule 16 ("Insurance & Securities (Renewal Term)"). The only changes between the former undertaking to provide liability insurance and the updated undertaking to provide liability insurance replacing it, shall be that coverage is to be provided to and including the new Expiry Date, in the amounts set out in the Province's notice of its election to renew, and possibly the name of the issuing insurer. In the event the Bonds are extended pursuant to their terms the evidence of said extension must be satisfactory to the Province, in its sole discretion;
 - (d) the foregoing condition precedents set out in Sections 3.4(b) and 3.4(c) are included for the sole benefit of the Province and may be unilaterally waived by the Province at any time prior to the dates specified for satisfaction of the conditions; and

- (e) subject to the satisfaction of the condition precedents in Sections 3.4(b) and 3.4(c) above or the waiver of same by the Province and the Province not terminating the Agreement prior to or on the original Expiry Date for an Event of Default, the Term of the Agreement will be extended for a further 5 Contract Years to and including August 31, 2031 and all the terms and conditions of the Agreement will continue to apply during this renewal [but for any further right of renewal] with any necessary changes as if the original Expiry Date had been the same as the Expiry Date of the renewal.

Notwithstanding the foregoing, the Province shall be under no obligation to renew, extend or renegotiate the terms of this Agreement following its termination or expiration.

4. LEGAL RELATIONSHIP – INDEPENDENT CONTRACTOR

- 4.1 The Contractor is an independent contractor and not the servant, employee, partner or agent of the Province unless otherwise specified in Sections 7.3 and 14.8.
- 4.2 The Contractor will not, in any manner whatsoever, commit or purport to commit the Province to the payment of any money to any person.
- 4.3 The Province may, from time to time, give such instructions to the Contractor as the Province considers necessary in connection with provision of the Services, which instructions the Contractor will comply with, but the Contractor will not be subject to the control of the Province with respect to the manner in which such instructions are carried out.
- 4.4 No partnership, joint venture or agency will be created or will be deemed to be created by this Agreement or any action of the Parties under this Agreement as between the Province and the Contractor.

5. TAX VERIFICATION

- 5.1 Any terms set out in the attached Schedule 19 apply to this Agreement

6. PRIME CONTRACTOR

- 6.1 The Contractor is the Prime Contractor in connection with the provision of the Services and this Agreement, and will, no later than 15 days after the Commencement Date, deliver to the Province:
 - (a) written notice of the name of the person appointed by the Contractor who will discharge the responsibilities of a “qualified coordinator” as described in the OHS Regulation and the Workers Compensation Act, for the Contractor; and
 - (b) a copy of the Safety Program.
- 6.2 Notwithstanding Section 6.1, the Contractor will not be designated as the Prime Contractor in the event the Services being rendered by the Contractor are within the limits of construction of an ongoing highway construction improvement project, in which case the construction contractor is designated by the Province as the Prime Contractor and the reporting protocol as between the Contractor, the construction contractor and the Province is set forth in Schedule 9 (“Prime Contractor Designation”).
- 6.3 The Province may, from time to time;
 - (a) on prior written notice to the Contractor, appoint a contractor other than the Contractor as the Prime Contractor in connection with works and activities that may be undertaken and

performed at any location or locations in the Electrical Service Area, for a period of time, and such works and activities, location(s), and period(s) of time will be specified and defined by the Province in the written notice; and

- (b) on conclusion of the works and activities referenced in Subsection (a), deliver written notice to the Contractor of the conclusion of such works and activities and, upon receipt of such notice the Contractor will resume the responsibilities of the Prime Contractor in connection with the Services and the Agreement at the applicable location.

7. SERVICES & WARRANTY

7.1 The Contractor will provide the Services to the Province, on or in respect of all Highways and Inventory within the Electrical Service Area, in accordance with the terms and conditions of this Agreement.

7.2 The Contractor will perform:

- (a) the Routine Maintenance Services in accordance with this Agreement; and
- (b) the Additional Services in accordance with this Agreement.

7.3 Any materials, equipment or improvements installed or deposited on the Highways by the Contractor during the Term as part of the Services, including any such items used in the repair or replacement of the Inventory, will immediately become the sole property of the Province and BCTFA and the Contractor will, at the request of the Province, assign or transfer to the Province any warranties available with respect to the same with accompanying documents and records. Notwithstanding Section 4.1, the Contractor will act on behalf of the Province with respect to warranty claims arising during the Term from Routine Maintenance Services performed by the Contractor unless the warranties have been assigned or transferred to the Province at its request. The Contractor is required by Section 14.8 to perform warranty work on Routine Maintenance Services as it arises.

7.4 Notwithstanding any other provision of the Agreement or the termination of the Agreement, the Contractor warrants to the Province for a period of 365 days following the actual completion date of any Services, whether Routine Maintenance Services or Additional Services, that the work is free from any defect resulting from the labour and/or material, if any, supplied by the Contractor as part of the Services and such warranty will survive the termination of this Agreement. The Contractor will, upon notification by the Ministry Representative during the Term, promptly and diligently remedy any defects that are warranted by the Contractor, to the satisfaction of the Ministry Representative. No additional compensation will be payable to the Contractor for remedying such defects.

8. CHANGES TO INVENTORY WITHIN ELECTRICAL SERVICE AREA

8.1 The Province may, in its sole discretion, for any purpose including but not limited to the transfer of the operation of a portion of the Highway to a third party, on one day's written notice to the Contractor to increase or decrease the level and/or types of Inventory within the Electrical Service Area, and the Contractor will perform the Services required with respect to the changed level or types of Inventory.

8.2 For the purposes of Section 8.1, where the Province has not provided the notice to the Contractor to amend the Inventory, notice will be deemed to have been given when a final inspection report by the Contractor of a new electrical installation is submitted to the Province.

8.3 In the event there is a change to Inventory pursuant to Section 8.1, the Annual Price will be adjusted if the cumulative net change in the Daily Cost for the then current Contract Year (determined in accordance with Section 8.4 and Schedule 6 ("Cost for Changes to Inventory") exceeds 2%, positive

or negative, as calculated by the Province in accordance with Section 8.5. In such case, the fees payable pursuant to Section 14.1 and that portion of the Annual Price attributable to the remainder of that Contract Year, will be adjusted by the change in Daily Cost determined by the Province under Section 8.5, from the effective date of the latest change made pursuant to Section 8.1 to the end of that Contract Year.

8.4 If the fees payable to the Contractor under Section 14.1 for a particular Contract Year are adjusted pursuant to Section 8.3, then the Contractor will not be entitled to any additional compensation in any form whatsoever, nor will the compensation payable hereunder be reduced, as a result of the changes referred to in any further notice delivered under Section 8.1 during that Contract Year unless the cumulative net change in the Revised Daily Cost for that Contract Year exceeds 2%, positive or negative, as determined by the Province in accordance with Section 8.5, and in each such case, the fees payable pursuant to Section 14.1 and that portion of the Annual Price attributable to the remainder of that Contract Year, will be adjusted by the change in the Revised Daily Cost determined by the Province under Section 8.5, from the effective date of the latest change made pursuant to Section 8.1 to the end of that Contract Year.

8.5 The Province will:

- (a) on or before the effective date of each notice delivered under Section 8.1, complete the calculations in Schedule 6 ("Cost for Changes to Inventory");
- (b) on or before the effective date of a change in compensation under Section 8.3 or 8.4, calculate a Revised Daily Cost in accordance with Schedule 6 ("Cost for Changes to Inventory"); and
- (c) provide copies of the calculations to the Contractor forthwith.

8.6 In the event there are changes to Inventory between the RFP closing date and the Commencement Date (whether such changes are an increase or decrease in Inventory), such changes will be reflected in a 30 day written notice from the Province to the Contractor and the Province will adjust the Annual Price for the First Contract Year pursuant to the calculations in Schedule 6 ("Cost for Changes to Inventory"). Furthermore, as a consequence of such changes in Inventory, the Province may in that notice also adjust the Insurance limits in Article 11 and Schedule 15 ("Insurance").

8.7 The calculations of the Province under this Article 8 will be final and binding on the parties.

8.8 The Contractor will be limited to the compensation adjustments as specified in this Article, and the Contractor will not have any other remedies either in contract under this Agreement or for claims for damages in tort with respect to any notices issued under Section 8.1.

9. CHANGES TO ROUTINE MAINTENANCE SERVICES

9.1 In order to promote and enhance public safety and efficiency, the Contractor will:

- (a) in consultation with the Province, continually review and re-evaluate the Routine Maintenance Services, including the methods, means, product and technology for providing the Routine Maintenance Services, and in conducting that review will take into account changing technology in the electrical services maintenance industry, changing methods, means, technology economic and environmental conditions and changing public requirements;
- (b) advise the Province if the Contractor considers that any part of the Routine Maintenance Services, including the methods, means, product and technology, should be changed in a material way, and submit the proposed change to the Province for its consideration; and

- (c) reasonably co-operate with the Province in tests to accommodate the new technology, methods, means and product of providing the Routine Maintenance Services.
- 9.2 The Province may, in its discretion and by delivering a Change Order to the Contractor, direct the Contractor to vary, amend or modify the Routine Maintenance Services, or any part thereof, whether as a result of reviews or proposals under Section 9.1 or on the Province's own initiative. The Change Order will specify the date by which the change is to be implemented by the Contractor.
- 9.3 When implementing the Change Order in Section 9.2, in the event there is an impact to the net costs in material, equipment and labour, the Contractor will obtain the best value for money when procuring any work, services, supplies, materials or equipment and will hold itself to a standard for the procurement that is no less than good industry practice.
- 9.4 The Parties acknowledge that not all Change Orders will include a net cost change to the Annual Price.
- 9.5 As a consequence of the Change Order, the Contractor will at its cost prepare and deliver to the Province a report within 30 days of the Contractor receiving the Change Order that includes:
- (a) the net amount of all cost changes (positive or negative), if any, in material, equipment and labour reasonably required to accommodate and implement the Change Order in a cost effective manner and provide overall value to the Province; and
 - (b) sufficient relevant information to enable the Province to properly evaluate the compensation adjustment, if any, relating to the Change Order including:
 - (i) the timing for implementing the compensation adjustment;
 - (ii) the estimated net amount of any cost savings to be realized;
 - (iii) a detailed summary of the prices, costs and charges used to calculate the compensation adjustment including supporting calculations; and
 - (iv) the calculation in (iii) above will be for a Contract Year that is comprised of a 365 day period.
- 9.6 If the Province agrees to the compensation adjustment and if such adjustment is effective for a portion of the Contract Year, the Province may at its discretion pay a prorated portion of the compensation adjustment for the remainder of that Contract Year. The full value of the compensation will be included in the next Annual Adjustment Process.
- 9.7 If the Province does not agree to the compensation adjustment to the Annual Price as identified in the Contractor's report pursuant to Section 9.5, then the Province will provide the Contractor with a written notice no less than 30 days from the delivery of the change report that:
- (a) cancels the Change Order;
 - (b) directs the Contractor to proceed with the Change Order with the compensation adjustment to be determined in accordance with the Dispute Resolution Protocol and the dispute will not affect the timely delivery of the change; or
 - (c) directs the Contractor to prepare an amended report based on an amended Change Order that will accompany the notice, and thereafter the Parties will follow the procedure set out in Sections 9.5 and 9.7(a) and (b) for that amended Change Order. For clarity, if the Parties do not agree to the compensation adjustment to the amended Change Order, the Province may then cancel the Change Order pursuant to Section 9.7(a) or invoke the Dispute Resolution Protocol pursuant to Section 9.7(b).

9.8 The Parties agree that the determination of the compensation adjustment pursuant to the Dispute Resolution Protocol is binding and is the only relief and compensation to which the Contractor will be entitled in respect of a Change Order and the Contractor will have no other claims or remedies either in contract or for damages in tort under or in connection with this Agreement or any notices issued under this Article 9.

9.9 The Contractor will not receive the compensation adjustment while the Dispute Resolution Protocol is in process and the Province will make any payment adjustments to the Annual Price or Adjusted Annual Price (as the case may be) based on the determination of the Arbitrator.

10. PROVINCIAL MATERIAL

10.1 The Province will supply the Contractor with the Provincial Material as detailed in Schedule 13 ("Provincial Material List") prior to or on the Commencement Date and the Contractor will accept it on an "as is" basis and acknowledges that the Province has made no representations or warranties with respect to its condition. The Provincial Material will, at all times, remain the exclusive property of the Province and the Province may, in its sole discretion, as applicable, transfer ownership of the same, or any part thereof, to the Contractor. At the expiry or termination of this Agreement, the Contractor will return all Provincial Material to the Province including but not limited to all manuals and reports (including any electronic and hard copies made by the Contractor), to the Province which has not been so transferred to the Contractor. The Provincial Material will be returned by the Contractor in the same condition it was given to the Contractor, in working order. If any part of the Provincial Material is lost, damaged or reaches its end-of-life before the expiry of this Agreement, that material will be replaced by the Contractor with the same product or with a comparable product to the Province's satisfaction.

10.2 The Contractor may reuse removed or recovered Inventory only with the written consent of the Province.

11. INSURANCE AND INDEMNITY

11.1 The Contractor shall obtain at its sole cost and expense, and maintain in good standing during the Term, insurance in such amounts, in such form of policy, containing such terms and against such risks, all as may be acceptable to the Province from time to time, acting reasonably. Without limiting the generality of the foregoing, the terms of such insurance shall meet the insurance requirements described in Schedule 15 ("Insurance") and placed with an insurer or insurers acceptable to the Province.

11.2 The Contractor will submit evidence of coverage in accordance with Section 2 of Schedule 15 ("Insurance") and the Contractor will, upon the request of the Province made at any time or times, submit to the Province evidence, satisfactory to the Province, that the insurance remains in force and effect. Evidence of the extension or the renewal of such insurance policy shall be delivered or caused to be delivered to the Province by the Contractor in accordance with subsection 3.4(b). Delivery of the evidence of insurance and its extension or its renewal as required by the terms of this Agreement in no way releases the Contractor of its obligations pursuant to insurance requirements in this Agreement and does not operate as a waiver by the Province of any of its rights.

11.3 If notice of cancellation or material change is given in accordance with Section 6 of Schedule 15 ("Insurance") the Contractor's obligations under Section 11.1 will continue in effect.

11.4 If any policy of insurance contains a co-insurance clause, the Contractor shall maintain or cause to be maintained in force a sufficient amount of such insurance to meet the requirements of any such co-insurance clause so as to prevent the Province, or the Contractor from being a co-insurer under the terms of such policy or policies to the amount insured in the event of loss, less any deductibles.

- 11.5 The Contractor will provide 30 days' written notice to the Province of any expiry, non-renewal, lapse, refusal to extend by the insurer, cancellation or any material change of the insurance policy or policies required by the Contractor pursuant to this Article.
- 11.6 The Contractor will, at the request of the Province, in the Province's sole discretion, secure insurance to replace the insurance coverage provided in compliance with Section 11.1 with new coverage terms or increased policy limits, as specified by the Province.
- 11.7 The Province may, in its discretion, review the insurance requirements stipulated by this Article and Schedule 15 ("Insurance") and the Contractor will cooperate as required to implement any changes arising from this review.
- 11.8 The Contractor shall, at the request of the Province, provide all information, including loss history information that may be requested from time to time.
- 11.9 The Contractor shall, upon the demand of the Province, deliver underwriting information and pertinent details of the claims history, including the details of the occurrence or accident and final disposition of any such occurrence or accident, in relation to the commercial general liability "all risks" insurance policies to be maintained pursuant to this Agreement.
- 11.10 Without limiting the generality of subsection 13.1(e), within the time period specified by the Province in any written demand, the Contractor shall provide the Province with information and supporting documentation to the satisfaction of the Province that the annual insurance premium amounts are true and correct or reflect or are commensurate with available reasonable market rates, and as verified by the statutory declaration of any director, officer, or employee of the Contractor or any representative of the Contractor's insurer or insurers, of:
- (a) the true and correct premium cost of the commercial general liability insurance required by section 11.1 and Schedule 15 ("Insurance") of this Agreement (excluding the premium for any sudden and accidental pollution liability portion of such coverage), for the current, previous or subsequent Contract Year;
 - (b) the availability or otherwise of alternative market-based quotes that may be obtained, including on a competitive basis, for the annual premium at the renewal or replacement of such insurance, to maintain such renewed or replacement insurance in force; and
 - (c) the Insurance Premium Quote or any subsequent annual insurance premium amounts delivered pursuant to Subsection 11.10(a) is true and correct competitively established, market premium amounts.
- 11.11 Without limiting any rights, powers and remedies existing available to the Province under this Agreement, any other agreement, at law or in equity, if the Province is not satisfied with any information and documentation delivered by, or on behalf of, the Contractor pursuant to section 11.10, the Province may, in its sole discretion, deliver notice in writing to the Contractor, requiring the Contractor to use its best efforts to obtain the requisite insurance from an alternative insurer or insurers, on a competitive basis, at more competitive rates, or at rates that more closely reflect or are commensurate with available reasonable market rates, and upon receipt of such request, the Contractor shall use its best efforts to obtain such insurance on such basis and at such rates as set out above.
- 11.12 The Contractor will indemnify and save harmless the Province from and against all Claims, liabilities, demands, losses, damages, costs and expenses, legal defence costs and expenses, fines, penalties, assessments and levies made against or incurred, suffered or sustained by the Province at any time or times (whether before or after the expiration or sooner termination of this Agreement) where the

same or any of them are based upon or arise out of or from anything done or omitted to be done by the Contractor and its Subcontractors or any of them pursuant to this Agreement including, without limitation, any Claim against the Province for failure to supervise or inspect the work which is performed by the Contractor pursuant to this Agreement which indemnity will survive the expiration or sooner termination of this Agreement.

11.13 Notwithstanding the provisions of the *Limitation Act*, S.B.C. 2012, c.13 the time for the Province to bring a claim for contribution or indemnity begins to run on the date on which the Province is called upon to make a payment in respect of a claim to which this indemnity may apply.

11.14 The Contractor will be responsible for compliance with all conditions and regulations under the *Workers Compensation Act*, and for all assessments and levies which may be made thereunder.

12. BONDS

12.1 The Contractor will obtain and maintain the Bonds in full force and effect during the Term subject to the provisions of this Article 12 and in the form of Schedule 14 ("Bonds").

12.2 The Bonds will both be issued by one surety company created and existing under the laws of Canada and duly authorized to transact the business of suretyship in Canada and the Bonds will be delivered by the Contractor to the Province prior to or on execution of this Agreement.

12.3 No later than six months before the date of renewal, if applicable, the Contractor will deliver to the Province the amendment and extension agreements executed by the Contractor and the surety in the forms provided in Schedule 14 ("Bonds").

12.4 Notwithstanding Section 12.3, if the Contractor selects an alternate surety company, that surety company must be acceptable to the Province at the Province's discretion, and the bonds must be in the form provided in Schedule 14 ("Bonds") with the same penal amount, etc.

12.5 In the event of a renewal of the Agreement pursuant to Section 3.4, the provisions of Sections 12.1 – 12.4 will apply, *mutatis mutandis*, to the renewal period.

13. CONTRACTOR'S COVENANTS

13.1 The Contractor will:

- (a) observe, abide by and comply with all laws, by-laws, orders, directions, rules and regulations of any competent Government Authority or branch or agency thereof directly or indirectly applicable to the Contractor under this Agreement, or the Services to be performed under this Agreement including but not limited to local municipal bylaws, the *Motor Vehicle Act and Regulations*, the *Workers Compensation Act* and the *OHS Regulation*, the *Safety Standards Act* and the *Electrical Safety Regulation B.C. Reg 100/2004*, the *Transportation Act*, and the *Canadian Electrical Code*, whether directly or indirectly applicable to the Contractor or this Agreement, including by ensuring that the provision of and performance of the Services, complies with all such laws, by-laws, orders, directions, rules and regulations;
- (b) ensure that the representations and warranties set forth in Article 2 are true and correct at all times during the Term and provide evidence to that effect to the Province on the written request of the Province;
- (c) maintain its corporate existence and carry on and conduct its business in a proper business-like manner in accordance with good business practice and keep or cause to be kept proper books of account in accordance with generally accepted accounting principles or international financial reporting standards, whichever is applicable to the Contractor, applied on a consistent basis;

- (d) not commit any act of bankruptcy, become an insolvent person or otherwise cease to function as a going concern, make an assignment for the benefit of its creditors, adopt any plan in connection with (or otherwise permit) the dissolution, liquidation, winding up, bankruptcy or reorganization of the Contractor, or attempt to avail itself of any applicable law relating to insolvent debtors;
- (e) within 15 days of the delivery of a written demand from the Province, provide the Province with such information and documents with respect to the affairs of the Contractor as the Province may reasonably request;
- (f) punctually pay as they become due all accounts, expenses, wages, salaries, taxes, levies, rates, fees, contributions and assessments required to be paid by it on any of its undertaking in connection to this Agreement;
- (g) observe, perform and comply with each covenant and agreement on its part contained in this Agreement;
- (h) provide and maintain all financial management and technical expertise necessary for the Contractor to carry out its obligations under this Agreement;
- (i) co-operate with the Province, the Highway Maintenance Contractor and any other contractors providing services to the Province in the Electrical Service Area and in areas adjacent to the Electrical Service Area to ensure that the Contractor provides the Services in a manner that is compatible with the services provided by the Province and these third parties. This cooperation includes but is not limited to lock-out procedures;
- (j) apply its best efforts and will work in close cooperation and harmony with the Province and will meet or exceed the Specifications and performance time frames included in the Specifications, free of Deficiencies (as defined in Schedule 1 ("Specifications")) and through competent staff, all to the satisfaction of the Province;
- (k) continually train its staff:
 - (i) in the safe operation of electrical maintenance services equipment and facilities to the satisfaction of the Province including but not limited to ensuring that during the first Contract Year any of the Contractor's staff working on traffic signal equipment are IMSA (International Municipal Signal Association) Traffic Signal Level 1 certified, and that during the remainder of the Term of the Agreement any such staff are IMSA Traffic Signal Level 2 certified; and
 - (ii) for new technology, changing methods and changing means for providing the Routine Maintenance Services;
- (l) provide and maintain at all times sufficient staff, facilities wherein no less than one maintenance facility shall be in the Service Area, materials, appropriate equipment within the Electrical Service Area and approved subcontract agreements in place and available to it as required to fully perform the Services, and in no event will the level of resources deployed in the field and ready to respond be less than what is required to supply the Additional and Routine Maintenance Services;
- (m) ensure that all Operational Vehicles and Equipment (as that term is defined in Schedule 11 ("Equipment Fleet Operations Policy")) meet all requirements of Schedule 11 ("Equipment Fleet Operations Policy"), and such other policy directives of the Province delivered to the Contractor from time to time;

- (n) with respect to the Contractor, any Subcontractors and any hired equipment operators involved in the performance of Services, ensure that:
 - (i) such persons maintain a minimum NSC safety rating of "satisfactory" or "satisfactory unaudited"; and
 - (ii) such persons and their drivers comply with the requirements of section 37.12 of the MVAR;
- (o) with respect to the Contractor, ensure that, if at least 10% of the vehicles operating under the Contractor's NSC certificate number are subject to a CVSA inspection, the results of such inspections shall not be greater than a 20% out of service (OOS) rate for mechanical safety violations over any 12 month period;
- (p) notwithstanding any limitation in the OHS Regulation which would exempt the Contractor from the requirement to initiate and at all times maintain an occupational health and safety program, initiate and at all time maintain the Safety Program in connection with the Services and this Agreement, and ensure that the Safety Program:
 - (i) is designed to prevent injuries and occupational diseases within the contemplation of the *Workers Compensation Act* and the *OHS Regulation*;
 - (ii) provides for the establishment and maintenance of a system or process to ensure compliance with the *Workers Compensation Act* and the *OHS Regulation* in respect of the Services and this Agreement; and
 - (iii) satisfies the requirements of an occupational health and safety program under the *Workers Compensation Act* and the *OHS Regulation*;
- (q) subject to Article 6, discharge the responsibilities of the Prime Contractor under the *Workers Compensation Act* and the *OHS Regulation*, in connection with the Services and this Agreement;
- (r) upon receipt of the Province's written notice under Article 6.3, cooperate in good faith with the contractor appointed the Prime Contractor for the location and the period of time described in the Province's notice, including the coordination of health and safety activities;
- (s) perform all of the Contractor's obligations included in the Specifications;
- (t) no later than 30 days prior to the Commencement Date, provide to the Province all of the Contractor information specified in Schedule 18 ("Contractor Details") with respect to a corporate Contractor, a Contractor that is a partnership and each corporate partner of a Contractor that is a partnership, and a Contractor that is a joint venture, and each joint venture member;
- (u) no later than 30 days prior to the Commencement Date, provide to the Province an executed Privacy Protection Schedule in the format specified in Schedule 17 ("Privacy Protection");
- (v) provide a toll-free telephone number which the public can use to contact the Contractor, and which will be manned or monitored by the Contractor 24 hours a day, seven days a week;
- (w) at all times promptly address, investigate and perform corrective maintenance as required, arising from Services complaints from members of the public, regulatory agencies, police authorities, local governments and the province of British Columbia and track same for the purpose of identifying trends and informing the Province of those trends;

- (x) submit its traffic management plan, to the standards of the Traffic Management Guidelines, to the local District Manager of Transportation (DMT) for preapproval prior to the commencement of Services in which there will be a road or lane closure and upload an update(s) to DriveBC;
- (y) contact and accept direction of the Ministry's local avalanche technician prior to commencing Services in an avalanche zone where the hazard is posted as "low" or greater;
- (z) provide accurate infrastructure locates to third parties as part of the Contractor's Routine Maintenance Services and the Contractor will also confirm the infrastructure locates prior to commencement of its own work;
- (aa) create and maintain an inventory of all electrical inventory in the Electrical Service Area, in compliance with the reporting requirements set out in Article 19; and
- (bb) no later than 30 days upon completion and prior to payment of invoice, provide record drawings of modifications or amendments to Inventory for both Routine Maintenance Services, and for Additional Services in hardcopy to the Ministry Representative listed at Section 25.1 and Electrical Engineering at TRAN.ElectricalandITSDrawings@gov.bc.ca (or such other email addresses that the Province may notify the Contractor in writing from time to time). For clarity, these record drawings need not be signed and sealed by a professional engineer

14. ANNUAL PRICE AND FEES

- 14.1** In consideration of the Contractor providing the Routine Maintenance Services and performing all other obligations of the Contractor under this Agreement, the Province will, subject to the terms of this Agreement including Section 22.2 and Article 24, pay to the Contractor the Annual Price corresponding to each Contract Year in the manner set out in Part 1 of Schedule 5 ("Fee").
- 14.2** Except as specifically provided in this Article 14, the sums described in Section 14.1 constitute the maximum amounts payable to the Contractor for its performance of the Routine Maintenance Services and the Contractor will not be entitled to any additional compensation for its performance whether or not the work actually undertaken by the Contractor is described in this Agreement and without limiting the generality of the foregoing, the Contractor will not be entitled to any compensation in a Contract Year beyond the Annual Price for that Contract Year unless the Annual Price is adjusted by the Province during that Contract Year in accordance with this Agreement.
- 14.3** In consideration of the Contractor providing Additional Services, the Province will pay the Contractor in accordance with Schedule 8 ("Additional Services").
- 14.4** Notwithstanding any other provision of this Agreement, the payment of money by the Province to the Contractor under this Agreement is subject to:
- (a) there being sufficient monies available in an Appropriation to enable the Province, in any fiscal year or part thereof when any payment of money by the Province to the Contractor falls due under this Agreement, to make that payment; and
 - (b) Treasury Board, as defined in the FAA, not having controlled or limited, under the FAA, expenditure under any Appropriation referred to in Subsection (a) of this section.
- 14.5** All sums due and owing by the Contractor to the Province under this Agreement will be set off by the Province during the Term.

- 14.6 All payments made under this Agreement, net of sums set off as provided under Section 14.5, will be paid by electronic fund transfer to the appropriate party.
- 14.7 Concurrent with each setoff payment, the Province will deliver to the Contractor an accounting of the sums due and owing by the Parties to the date of the payment.
- 14.8 The Contractor will be required as part of its Routine Maintenance Services to repair or replace any item of Inventory which:
- (a) was installed by a party other than the Contractor and/or on which an installer, manufacturer and/or supplier's warranty exists; and
 - (b) has to be repaired or replaced within a warranty period provided by that installer, manufacturer and/or supplier, and the Province may:
 - (i) pursue a Claim against the installer, manufacturer and/or supplier and if successful, will reimburse the Contractor any such recovered amount, minus all reasonable expenses incurred in making the Claim; or
 - (ii) direct the Contractor to act on behalf of the Province with respect to warranties and Claims thereof (including but not limited to LED lights and battery warranties) and if successful, the Contractor will retain any such recovered amount;
- and the Contractor will not make or purport to make on its own behalf or on behalf of the Province any Claim whatsoever against such installer, manufacturer and/or supplier as a result of such defect, and assigns to the Province all of its rights to make any such Claim unless the Province and the Contractor confirm in writing that the Contractor will act on behalf of the Province in the making and the pursuit of a particular Claim.
- 14.9 If the Contractor is directed by the Province as part of Routine Maintenance Services to replace any Inventory item with an item of a different type and costing more to replace than the replacement item required under the Specification, then the Province will pay the Contractor the difference between such material and equipment costs with no markup for overhead and profit.
- 14.10 If the Contractor is required as part of Routine Maintenance Services to replace more than 100 failed LED signal head light sources in a Contract Year (the "LED Cap") then, the Province will at its discretion either supply the Contractor with the additional signal head light source LEDs or reimburse the Contractor for the direct cost of purchasing same (with no markup for profit or overhead) always subject to the signal head light source LEDs below the LED Cap not having failed due to vandalism or breakage. In addition, the Contractor must present the Province with the invoices concerning the purchase of same as part of the next monthly report. For greater certainty, the labour and equipment to replace all failed signal head light source LEDs (above and below the LED Cap) are included in Routine Maintenance and are therefore not subject to additional compensation.
- 14.11 Included in the Annual Price is a sum for work to replace or upgrade aging items of Inventory in the Electrical Service Area (such sum inclusive of all labour, equipment and materials but for the replacement of HID lighting Inventory for which the sum shall only include materials costs). This sum for the First Contract Year is \$310,000 and this sum is subject to the provisions of Schedule 7 ("Annual Adjustment Process"). The value of the work completed under the Work Plan will be credited using a value as agreed to by both Parties or as determined by the Province by utilizing the Cost Plus Rates in Schedule 8 ("Additional Services"). ***[Note to draft: amend to accord with the Price Proposal and delete this note]***

- 14.12 In the event this Agreement is renewed for a further five (5) Contract Years, the Province will apply the cumulative Price Adjustment Factor described in Schedule 7 ("Annual Adjustment Process") to that \$310,000 in Section 14.11, for the sum that will become the new value for work to replace or upgrade aging items of Inventory for the renewal term. Except for mathematical error by the Province in applying the cumulative Price Adjustment Factor, the Contractor cannot dispute the new value of Inventory upgrades and the Parties will be bound to the amendment. *[Note to draft: amend to accord with the Price Proposal and delete this note]*
- 14.13 Each Contract Year, the Contractor will deliver to the Province a Work Plan, pursuant to the form provided by the Province, for upgrading aging Inventory satisfactory to the Province:
- (a) that includes a detailed description of the items of Inventory to be upgraded, the location, and anticipated completion date, including: *[Note to draft: amend (a) to accord with Price Proposal and delete this note]*
 - (i) all HID lighting Inventory will be replaced with LED technology over the course of the first five Contract Years in such annual increments as determined by the Contractor];
 - (ii) the replacement with LED technology in (i) above is expected to be approximately 5,000 lighting Inventory as of the First Contract Year Inventory.
 - (b) by no later than 30 days after the Commencement Date, for the First Contract Year; and
 - (c) each year thereafter on or before an Anniversary Date, for the Contractor Year commencing on that Anniversary Date.
- 14.14 When the Work Plan is submitted by the Contractor to the Ministry Representative for approval, the Ministry Representative will, as soon as reasonably practicable, and in any event not later than 5 Working Days after receiving the proposed Work Plan, advise the Contractor whether the plan is satisfactory to the Province and, if not satisfactory, in what respects it is not satisfactory. The Province will consider, without limitation, the prioritization of the work and costs in evaluating the Contractor's Work Plan for approval. If the Contractor does not deliver the Work Plan by the applicable date as specified herein, the Province may impose on the Contractor a Work Plan by delivering to the Contractor a copy of the Work Plan as prepared by the Province.
- 14.15 In the event the work is not completed in accordance with the Work Plan, for clarity the Province will consider such event an Event of Default.

15. DAMAGE TO GOVERNMENT PROPERTY

Damage to Government Property Invoice

- 15.1 The Contractor is responsible for all costs to repair Damage to Government Property except for the cost of materials over \$2,000.00 per incident. The Contractor will submit an invoice to the Province for the cost of materials that exceed \$2,000.00.
- 15.2 At the Province's discretion, in the event the Contractor fails to submit an invoice within 30 days of completion of the repair to Damage to Government Property, the Contractor may no longer be entitled to reimbursement for the cost of materials that exceed \$2,000.00 from the Province pursuant to Section 15.1.

Damage to Government Property Claim

- 15.3 The Contractor must submit to the Province a Damage to Government Property Claim for all Damage to Government Property. The Damage to Government Property Claim must include all costs incurred

by the Contractor and the Province to repair the damage and must be accompanied by supporting documentation, including any documentation required by a third party's insurer for the Province's Damage to Government Property Claim to proceed. Subject to Sections 15.1 and 15.5, the Province shall reimburse the Contractor for any of the Contractor's costs if the Province is satisfied that:

- (a) the Contractor's costs have been solely and properly incurred for the purpose of repairing or restoring Government Property damaged by persons other than the Contractor or the Controlled Persons; and
- (b) all such repairs or restorations of Damage to Government Property damages by persons other than the Contractor or the Controlled Persons have been repaired or restored in accordance with this Agreement.

15.4 For certainty:

- (a) GPS Coordinates will be used to determine and describe the location; Subcontractors are not considered third parties for this purpose; and
- (b) a Damage to Government Property claim is not applicable to instances of Stolen Wire.

15.5 If the Province has made a successful Damage to Government Property Claim and has recovered an amount against a third party (insurer or the responsible party) for damage to Inventory or other Government Property (the "Recovered Amount"), and where that damage was repaired or replaced by the Contractor as part of Routine Maintenance Services, the Province will give the Recovered Amount to the Contractor minus all reasonable expenses incurred by the Province in making the Damage to Property Claim. In no event will the Province reimburse the Contractor an amount in excess of that net Recovered Amount, and in the event the Province (whether by its own forces or by its contractor) also performed some of the repair or replacement, the Province may also allocate the net Recovered Amount proportionately between itself and the Contractor, based on the expenses incurred by each party to repair or restore the Inventory or other Government Property. This Section 15.5 will survive the expiry or termination of this Agreement.

15.6 The Contractor will not make or purport to make on its own behalf or on behalf of the Province any Damage to Government Property Claim whatsoever for damage to Inventory or other Government Property except to claim to the Province for the Recovered Amount under the terms and conditions of Section 15.5, and the Contractor hereby assigns to the Province all of its rights to make a Claim with respect to damage to Inventory or other Government Property. The Contractor agrees that the decision to make a Claim and all decisions respecting the conduct of a Claim will be within the Province's sole discretion.

15.7 The Contractor will co-operate with the Province and its legal counsel and professional advisors in any and all investigations, settlements and judicial determinations of any Claims made against the Province or the Contractor and any Damage to Government Property Claims relating directly or indirectly to this Agreement and will cause the Subcontractors to be similarly bound.

16. **STOLEN WIRE**

16.1 If the cost of work associated with the replacement of Stolen Wire and Hardening is less than \$30,000 for a Contract Year (the "Wire Theft Cap"), then the work is part of Routine Maintenance Services and will be carried out by the Contractor without additional compensation. The value of this work below the Wire Theft Cap is calculated pursuant to the Cost Plus Rates in Schedule 8 ("Additional Services").

- 16.2 If the cost of work associated with the replacement of Stolen Wire and Hardening is equal to or greater than the Wire Theft Cap for that Contract Year, the Province will elect either to:
- (a) whether by its own forces or by another contractor, perform the work, with this election being made on a case by case basis and for each incident of Stolen Wire in that Contract Year; or
 - (b) have the Contractor replace the Stolen Wire and perform Hardening.
- 16.3 If the Province elects the Contractor to do the work exceeding the Wire Theft Cap, the Province will pay the Contractor for the replacement of Stolen Wire and Hardening in accordance with the Cost Plus Rates in Schedule 8 ("Additional Services").
- 16.4 At the Province's discretion, in the event the Contractor fails to submit a claim for reimbursement within 30 days of completion of this work to replace the Stolen Wire and perform Hardening pursuant to Section 16.2(b), the Contractor may no longer be entitled to reimbursement from the Province pursuant to Section 16.3 and if the Wire Theft Cap is reached part way through a particular month, then the Contractor will include that information in its monthly written report and provide supporting invoices for that portion of the work that exceed the Wire Theft Cap.
- 16.5 In the event this Agreement is renewed for a further five (5) Contract Years, the Province will apply the cumulative Price Adjustment Factor in Schedule 7 ("Annual Adjustment Process") to that \$30,000 sum and that value will become the new Wire Theft Cap. Except for mathematical error by the Province in applying the cumulative Price Adjustment Factor, the Contractor cannot dispute the amendment of the new Wire Theft Cap and the Parties hereto will be bound to the amendment.
- 16.6 All incidents of Stolen Wire must be reported to the police by the Contractor.
- 16.7 The Contractor will keep accurate and up to date accounts on its replacement of Stolen Wire and Hardening and will provide that information to the Province in its monthly reports along with supporting invoices, when applicable. (The locations will be described with GPS Coordinates. for the purposes of reporting and payment.)
- 16.8 For certainty, Subcontractors are not considered third parties for this purpose and this Article 16 is not applicable to Damage to Government Property.

17. ELECTRICAL PERMITS

- 17.1 Any cost increases over and above the amount of \$2,000.00 per Contract Year in the fees charged to the Contractor for obtaining annual electrical permit(s) for performing the Services within the Electrical Service Area will be reimbursed to the Contractor by the Province. In the event the Contractor determines that such fees are likely to exceed \$2,000.00, then the Contractor will notify the Ministry before incurring such fees to provide the Ministry with an opportunity of addressing the matter with the appropriate regulatory authority before the fees are incurred by the Contractor.

18. ASSIGNMENT, SUBCONTRACTING

- 18.1 The Contractor will not without the prior written consent of the Province assign, either directly or indirectly, this Agreement or any right of the Contractor under this Agreement and the Contractor will reimburse the Province forthwith on demand the Province's administrative and other costs, including legal costs, in respect of the assignment of this Agreement.
- 18.2 The following events will be deemed to be an assignment of the Contractor's rights and obligations under this Agreement:
- (a) if the Contractor is a corporation but none of its shares are traded on any public stock

exchange or in any public stock market, any transaction, amalgamation, arrangement, reorganization, joint venture, trust or other agreement which will result in a direct or indirect change of control of such corporation or direct or indirect change of ownership of the business during the Term; or

- (b) if the Contractor is a partnership, the cessation, other than through death, at any time during the Term by any person who at the time of the execution of this Agreement owns a partner's interest, or such ownership, or a material change in the ownership, in the opinion of the Province, of such partner's interest.

- 18.3 The Province may, in its sole discretion, assign this Agreement or any right or obligation under this Agreement to any corporation or agency of the Province of British Columbia and, with the prior written consent of the Contractor to any other person provided that such corporation or agency of the Province of British Columbia or other person agrees in writing to be bound by the terms of this Agreement and perform all obligations of the Province under this Agreement prior to such assignment taking place. The Province will promptly notify the Contractor of any such assignment and provide a copy of the written agreement of the assignee confirming that it is bound by the terms of, and will perform all of the obligations of the Province under this Agreement.
- 18.4 The Contractor may subcontract any obligation of the Contractor under this Agreement to any person except if the Province has notified the Contractor that the Province's written consent is to be obtained prior to any such subcontracting by the Contractor.
- 18.5 The appointment of Subcontractors by the Contractor will not relieve the Contractor of its responsibility to perform and comply with all terms of this Agreement, or for the quality of work, materials and services provided by it.
- 18.6 The Contractor will at all times be held fully responsible to the Province for the acts and omissions of its Subcontractors, Controlled Persons and persons employed by them and no subcontract entered into by the Contractor will impose any obligation or liability upon the Province to any such Subcontractor, Controlled Person or any of its employees.
- 18.7 The Contractor will cause every Controlled Person and Subcontractor to be bound by the terms of this Agreement so far as they apply to the Services to be performed by each Subcontractor.
- 18.8 Nothing in this Agreement will create any contractual relationship between the Province and a Subcontractor or Controlled Person of the Contractor.
- 18.9 The Contractor will use its best efforts to co-operate with the Province, and any other interested parties to effect a full or partial assignment of the Province's rights and obligations under this Agreement, and a reasonable transition in performance of the Services as a result of any assignment, expiration or termination of this Agreement and this obligation will survive such expiration, termination or assignment.

19. RECORDS AND REPORTS

19.1 The Contractor will:

- (a) establish and maintain at a location within British Columbia accurate books of account and records (including supporting documents) to the satisfaction of the Province;
- (b) give written particulars of the location within British Columbia, referred to in Section 19.1(a), to the Province, not later than 30 days after the Commencement Date, or give written particulars of any new location within British Columbia within 30 days of any change of location;

- (c) permit the Province, its employees, servants, contractors and agents, at any time or times during normal business hours, to copy or audit, or both, any or all of the books of account and records (including supporting documents) referred to in Section 19.1(a);
 - (d) establish, maintain and comply with a work reporting system (including a computerized maintenance management system) satisfactory to the Province; and
 - (e) maintain the Inventory list that is initially provided to the Contractor by the Province prior to the Commencement Date of this Agreement. The Contractor will verify that the list is correct and will be responsible for updating the list when Inventory increases or decreases as appropriate.
 - (f) provide to the Ministry Representative no later than the Anniversary date of each Contract Year, a current inventory spreadsheet of all Inventory with electrical service panels and all Inventory that is solar powered in the Electrical Service Area, which must meet the following requirements:
 - (i) locations must be identified by the GPS Coordinates of each service panel and solar powered site with a breakdown of the infrastructure connected thereto; and
 - (ii) notwithstanding the annual requirement set out in this Section 19.1(f), the Contractor will have up to the first two Contract Years of the Term in which to submit that Inventory spreadsheet referenced in this Section 19.1(f) with GPS coordinates, with a minimum of 50% of that report to be submitted in the First Contract Year and no less than the whole of that report to be submitted in the second Contract Year;
 - (g) provide to the Province by no later than 30 days after the Commencement Date, for the First Contract Year, and each year thereafter on or before the Anniversary Date of each Contract Year, waste management plan(s), detailing the items to be disposed of and the location of such disposal, and, if reclamation is required in connection with such disposal, the reclamation procedures to be carried out in connection therewith; provided that:
 - (i) if the waste management plan(s) require no revision or amendment, the Contractor shall provide to the Province a nil report; and
 - (ii) if, within the current Contract Year, there is a change (which for certainty, includes, but is not limited to, an addition or deletion) to the waste management plan(s), the Contractor shall provide a revised or amended waste management plan(s) to the Province as soon as reasonably practicable within the current Contract Year;
 - (h) provide to the Ministry Representative no later than the Anniversary date of each Contract Year, a report regarding implementation of staff training pursuant to Section 13.1(k);
 - (i) provide a senior officer's or director's certified replacement for Schedule 18 ("Contractor Details") no later than the 10th Working Day following the preceding month in which a change occurred to the Contractor's details provided in Schedule 18 ("Contractor Details").
- 19.2** No later than the 10th Working Day following the preceding month, the Contractor will submit monthly written reports to the Province on the scheduled and the completed Services (unless otherwise identified in this Section 19.2) for the Contractor's activities as follows:
- (a) work identified, scheduled and completed by the Contractor for Routine Maintenance Services including work activity for each specification in Schedule 1 ("Specifications") and Schedule 2 ("Local Area Specifications");

- (b) written summaries of Additional Services which include scheduled and performed Additional Services itemized according to the Work Order as appropriate and pursuant to Schedule 8 ("Additional Services") and identified as to work location (highway #, intersection location, GPS Coordinates);
 - (c) a statement of account for:
 - (i) the replacement of all LED signal head lights, below and exceeding the LED Cap. Details should include date, location, specific signal head type, size, and colour;
 - (ii) the cost of the materials for Damage to Government Property exceeding \$2,000.00 per incident;
 - (iii) the cost of replacement of Stolen Wire and Hardening, below and exceeding the Wire Theft Cap. Details should include incident description, police file number, date, location, GPS Coordinates, and scope of repair;
 - (iv) the fees for annual electrical permits exceeding \$2,000 per Contract Year; and
 - (v) the cost and details for the collection of the controller volume and measure of effectiveness (MOE) logs that is:
 - (A) included as Routine Maintenance Services pursuant to Specification E-110 Section 2.1(f) of Schedule 1 ("Specifications"); and
 - (B) included as Guaranteed Additional Services when the 60% threshold of the pedestrian and traffic signal Inventory total per year is exceeded pursuant to Section 1.1(d)(iii) of Schedule 8 ("Additional Services");
 - (d) an updated Inventory list referenced in Section 19.1(e) above;
 - (e) an updated summary of Damage to Government Property Claims; and
 - (f) Work Plan progress.
- 19.3** The Contractor will, no later than the 30th Working Day after the Anniversary Date, provide to the Province a summary of the prior Contract Year that will include:
- (a) all matters referenced in Section 19.2;
 - (b) a report of all railway pre-emption and railway advance warning sign systems as jointly tested and inspected with the applicable railway authority;
 - (c) a summary of warranty work and items replaced under warranty (including, but not limited to, such items as LED signal head light sources, UPS units and batteries, electronic message signs and equipment); and
 - (d) an updated Provincial Material list.
- 19.4** The Contractor will, on or before the Anniversary Date of each Contract Year, provide to the Province:
- (a) the completed Inventory Change Detail form attached as Appendix 4 to Schedule 7 ("Annual Adjustment Process"); and
 - (b) the completed Insurance Premium Adjustment Form attached as Appendix 5 to Schedule 7 ("Annual Adjustment Process"), as originally signed by an authorized representative of the Insurer, on or before the Anniversary Date of each Contract Year, in respect of the commercial general liability insurance described in Article 11 (excluding any Sudden and Accidental pollution liability coverage), of the total amount payable, as the annual premium to maintain such renewal or replacement insurance in force for the duration of the subsequent Contract Year.

- 19.5** The Contractor will from time to time and such time(s) the Province may specify (unless otherwise identified in this Section 19.5):
- (a) deliver to the Province as required by the Province any or all records and reports demonstrating or relating to the compliance of the Contractor with the laws, by-laws, orders, directions, rules and regulations referenced in Section 13.1(a); and
 - (b) allow the Province full access to the records related to the Contractor's Quality Plan.
- 19.6** The Contractor will promptly return or provide to the Province at the expiry or the earlier termination of this Agreement without the need for the Province to make the request, all complete and accurate documentation including but not limited to reports/documents on the following items and matters in the appropriate Microsoft Office, Excel or Adobe Acrobat standard, including:
- (a) a summary report of all Damage to Government Property Claims for reimbursement made by the Contractor in Section 15.3 for the Term;
 - (b) all traffic signal record (the "TSR") forms;
 - (c) the conflict monitor testing schedule;
 - (d) the UPS testing schedule;
 - (e) the UPS testing results;
 - (f) the re-lamp schedule for all high intensity discharge lighting;
 - (g) the most current joint Contractor/railway authority joint testing and inspection reports;
 - (h) traffic controller programming data;
 - (i) an updated Inventory spreadsheet;
 - (j) any and all manuals, findings, data, specifications, drawings, working papers, reports, documents and other materials whether complete or incomplete that have been prepared by the Contractor; and
 - (k) an updated Provincial Material list.
- 19.7** The Province exclusively owns all property rights, including intellectual property rights and copyright, in all reports, manuals, findings, data, drawings, working papers, summaries and documents provided to the Province by or on behalf of the Contractor, whether complete or not, pursuant to Sections 19.1(e), (f), (h), and (i), 19.2, 19.3, 19.4(a), 19.5 and 19.6 to the Province (for the purpose of this Section 19.7, the "Documents"). Upon the Province's request, the Contractor must deliver to the Province documents satisfactory to the Province that irrevocably waive in the Province's favour any moral rights which the Contractor (or employees of the Contractor) or a Subcontractor (or employees of a Subcontractor) may have in the Documents and that confirm the vesting in the Province of the copyright in the Documents. This provision will survive the expiration or earlier termination of this Agreement.

20. FINANCIAL AUDIT

- 20.1** The Province may, in its sole discretion, conduct a financial and accounting audit of the Contractor, including the right to inspect and take copies of the books and records of the Contractor upon reasonable notice and at reasonable times.
- 20.2** The Contractor will fully co-operate with the Province in conducting an audit under this Article 20.

- 20.3 The Contractor will, upon the request of the Province, provide to the Province a copy of the audited (or if unavailable, unaudited) financial statements of the Contractor.
- 20.4 The Contractor will prepare such financial information, reports or statements relating to the Contractor's financial condition and accounting records as the Province may request and will deliver the same to the Province at such time(s) as the Province may specify.

21. QUALITY

- 21.1 The Contractor is responsible for the quality of the Services in accordance with this Agreement, the Specifications and the Contractor's Quality Plan.
- 21.2 The Contractor will prepare the Contractor's Quality Plan for the Services in accordance with the criteria set forth in Section 21.9 and provide the Contractor's Quality Plan to the Ministry Representative in accordance with the RFP Section 18.1.
- 21.3 Acceptance of the Contractor's Quality Plan by the Province in no way will release the Contractor from its obligation to perform all of the terms, covenants and conditions of this Agreement, including but not limited to the Specifications, all of which are expressly reserved by the Province and that if there is any conflict between the Contractor's Quality Plan, or any part thereof, and any term of this Agreement including the Specifications, the terms of this Agreement will prevail.
- 21.4 The Contractor will implement, maintain and conform to the Contractor's Quality Plan throughout the Term.
- 21.5 The Contractor is responsible for continually monitoring the effectiveness of, maintaining, and revising the Contractor's Quality Plan throughout the Term and will submit any resulting amendments to the Ministry Representative for acceptance.
- 21.6 The Contractor will assign the responsibility of implementing the Contractor's Quality Plan to one person who has the competency and proven capability, and who will work directly with the Ministry Representative on matters related to quality and will fully co-operate in all of the Province's monitoring and auditing activities as described in the Provincial Quality Plan.
- 21.7 The Province may audit the Contractor's Quality Plan and conduct monitoring, auditing and performance testing, at times and in a manner determined by the Ministry Representative, in order to ensure conformance with the Specifications, the terms of this Agreement, and the Contractor's Quality Plan through review of the Contractor's work activities and performance results and to verify the effectiveness of the Contractor's processes, procedures, methods, documentation, and records.
- 21.8 The Province may issue and deliver to the Contractor a Non-Conformance Report (the "NCR") if the results of the Province's monitoring or auditing activities indicate the Contractor is failing to conform to the terms of this Agreement.
- 21.9 The Contractor's Quality Plan will require, without limitation:
- (a) the documentation of all processes for all Routine Maintenance Services in detail;
 - (b) the documentation of the Contractor's processes to ensure quality control and quality assurance;
 - (c) an internal non-conformance process to be initiated by the Contractor when materials products or Services fail to meet the terms and conditions of this Agreement that, without limitation, includes the following:
 - (i) the methods used to determine the extent, location and quantity of the non-conforming material, product or Service;

- (ii) the methods used to resolve an incident or incidents of non-conforming materials, products or Services, whether they be replacement, rectification or a request to the Province to accept the non-conformance;
 - (iii) how the root cause leading to the non-conformance will be identified and analyzed;
 - (iv) the method or methods to ensure all similar incidents are prevented in the future;
 - (v) the method or methods used to determine the effectiveness of corrective and preventive measures; and
 - (vi) how the non-conformances and their resolution will be communicated within the Contractor's organization;
- (d) or the Contractor may request in writing to the Province that the non-conforming materials, products or Services be accepted by the Province.

22. DEFAULT AND REMEDIES

22.1 Any of the following events will constitute an Event of Default whether the event is voluntary, involuntary or results from the operation of law or any judgment or order of any court or administrative or government body:

- (a) the Contractor fails to observe, perform or comply with any provision of this Agreement;
- (b) the Contractor's failure to remedy a non-conformance set out in a Non-Conformance Report within the time specified in the Non-Conformance Report or any audit report;
- (c) any representation or warranty made by the Contractor in this Agreement is materially untrue or incorrect;
- (d) any information, statement, document, certificate or report furnished or submitted by or on behalf of the Contractor to the Province pursuant to this Agreement is materially untrue or incorrect;
- (e) the Contractor fails to deliver to the Province notice that there has occurred or is continuing a default under this Agreement, and which specifies the particulars of the default;
- (f) there is any action or proceeding, pending or threatened against the Contractor, which would, in the reasonable opinion of the Province, have a material adverse effect upon the ability of the Contractor to fulfill its obligations under this Agreement;
- (g) a floating charge granted by the Contractor crystallizes or becomes enforceable or any other action is taken to enforce any charge granted by the Contractor;
- (h) an order is made, a resolution is passed or a petition is filed, for the liquidation or winding up of the Contractor;
- (i) a change occurs with respect to any of the properties, assets, condition (financial or otherwise), business or operations of the Contractor which, in the reasonable opinion of the Province, materially adversely affects the ability of the Contractor to fulfill any of its obligations under this Agreement;
- (j) the Contractor becomes insolvent, commits an act of bankruptcy, makes an assignment for the benefit of its creditors or otherwise acknowledges its insolvency;
- (k) a bankruptcy petition is filed or presented against, or a proposal under the *Bankruptcy and Insolvency Act* (Canada) is made by, the Contractor;

- (l) a compromise or arrangement is proposed in respect of the Contractor under the *Companies' Creditors Arrangement Act* (Canada);
- (m) a receiver or receiver-manager of any property of the Contractor is appointed;
- (n) the Contractor permits any sum, which is not disputed to be due by it, to remain unpaid after legal proceedings have been commenced to enforce payment thereof;
- (o) the Contractor ceases, in the reasonable opinion of the Province, to carry on business as a going concern;
- (p) the Contractor, without the prior written approval of the Province, assigns, sells or in any manner disposes of or encumbers all or any of its interest in, or rights acquired under, this Agreement;
- (q) without the prior written consent of the Province, the direct or indirect legal or beneficial ownership and effective control of the Contractor changes from that represented in Schedule 18 ("Contractor Details");
- (r) any action is taken to enforce any security interest, charge or encumbrance granted, created or issued by the Contractor; and
- (s) the failure of the Contractor to comply with the requirements of Article 12.

22.2 On the happening of an Event of Default, or at any time thereafter, the Province's Regional Director may deliver written notice to the Contractor specifying the Event of Default and the Province may, at its option, elect to do any one or more of the following:

- (a) pursue any remedy available to the Province at law or in equity including any remedy available to it under the Bonds;
- (b) retain as a holdback from any payment due to the Contractor pursuant to Part 1 of Schedule 5 ("Fee");
 - (i) if the Event of Default is a failure to perform Additional Services in accordance with this Agreement, an amount equal to twice the value of that work not performed, as determined by the Province in the Province's sole discretion; or
 - (ii) if the Event of Default is a failure to perform Routine Maintenance Services in accordance with this Agreement, an amount equal to twice the value of the Routine Maintenance Services not performed, such value to be determined by the Province in the Province's sole discretion;
- (c) take all actions in its own name or in the name of the Contractor that may reasonably be required to cure the Event of Default in which case all payments, costs and expenses incurred will be payable by the Contractor to the Province on demand and set off against any sums owing by the Province to the Contractor, present or future, including any amount retained as a holdback under this Article;
- (d) require the Contractor to cure the Event of Default within a time period specified in the notice;
- (e) if an Event of Default with respect to which an amount has been retained as a holdback under this Article 22;
 - (i) has been cured by the Contractor to the satisfaction of the Province within a time period specified by the Province, then the Province may pay the amount retained to the Contractor; or

- (ii) is not curable or has not been cured by the Contractor to the satisfaction of the Province within a time period specified by the Province then the Province may keep the amount retained as a reduction of fees otherwise payable to the Contractor; and
 - (iii) the holdback, as determined according to this Section 22.2 and Schedule 5 ("Fee") or Schedule 8 ("Additional Services"), as the case may be, is an appropriate estimate of the losses and damages incurred by the Province arising from the Contractor's default, after taking into account, without limitation, the Province's increased administration costs, the costs of hiring an alternate Contractor to perform the Additional Services or Routine Maintenance Services, the delays in the performance of those Services and the costs associated with traffic closures or delays, if any, which resulted from the Event of Default;
- (f) waive the Event of Default;
 - (g) terminate this Agreement, subject to the expiration of any time period specified by Section 22.2 (d); and
 - (h) if the Event of Default is as described in Section 22.1(s), terminate this Agreement effective on the fourth Anniversary Date with respect to the failure of the Contractor to satisfy the requirements of Sections 12.3 and 12.4 and pursue the remedy provided for in the Bonds without a requirement by the Province to provide any notice.
- 22.3 The rights, powers and remedies conferred on the Province under this Agreement are not intended to be exclusive and each will be cumulative and in addition to and not in substitution for every other right, power and remedy existing or available to the Province under this Agreement, any other agreement, at law or in equity and the exercise by the Province of any right, power or remedy will not preclude the simultaneous or later exercise by the Province of any other right, power or remedy.
- 22.4 No failure or delay on the part of either party to complain of an act or failure of the other party or to declare such other party in default, irrespective of how long such act or failure to act will continue, will constitute a waiver by such party of its rights under this Agreement.
- 22.5 No interest will be payable by the Province on any amount retained as a holdback in accordance with this Article and Schedule 5 ("Fee") and or Schedule 8 ("Additional Services").
- 23. DISPUTE RESOLUTION**
- 23.1 Upon a dispute arising out of or in connection with any provision of this Agreement, either party may invoke the Dispute Resolution Protocol in Schedule 10 ("Dispute Resolution Protocol") by written notice to the other in order to attempt to resolve the dispute.
- 23.2 The Parties will confirm in writing any election by them to follow the Dispute Resolution Protocol in respect of a particular dispute and upon any such election being made, unless otherwise agreed by the parties, the Dispute Resolution Protocol will be binding on them in respect of that dispute.
- 24. FORCE MAJEURE**
- 24.1 If an event of Force Majeure is likely to occur, the party directly affected will notify the other party immediately, and will use its best efforts to remove, curtail or contain the cause of the delay, interruption or failure and to resume with the least possible delay performance of its duties, covenants and obligations under this Agreement.

- 24.2** If an event of Force Majeure does occur and if the party directly affected by the event of Force Majeure is the Contractor, then:
- (a)** the Province will not be obliged to pay to the Contractor any amount during the period of Force Majeure, nor will any payment obligation accrue for that period. Notwithstanding the foregoing, the Province will pay the Contractor for those items of Routine Maintenance Services that were performed in accordance with (b) below, although in no circumstances will payment for those items performed ever be more than the equal monthly installments pursuant to Schedule 5 ("Fee");
 - (b)** during the time period while the event of Force Majeure continues the Province will pay monthly fees to the Contractor for the direct costs incurred by the Contractor (excluding overhead costs) in performing items of Routine Maintenance Services calculated in accordance with Schedule 8 ("Additional Services"), such fees to be paid in arrears on the payment dates set out in Schedule 5 ("Fee") provided that the Contractor submits its written statement of account in respect of the fees claimed, including supporting invoices evidencing the Contractor's direct costs; and
 - (c)** during the event of Force Majeure, and subject to Schedule 8 ("Additional Services") Section 3.4, the Contractor will not be required to perform Additional Services, unless the Province or a Government Authority deems it to be an essential service.
- 24.3** If either party is aware or is made aware, through its dealings with the insurance industry or the electrical maintenance services industry, that an event of Force Majeure is likely to occur then that party will notify the other party and both Parties will enter into good faith negotiations with a view to entering into a mutually acceptable agreement that will prevent the event of Force Majeure from occurring.
- 24.4** If either party is aware or is made aware, through its dealings with the insurance industry or the electrical maintenance services industry, that an event of Force Majeure described in Section 1.1 has occurred, then that party will notify the other party immediately.
- 24.5** If the party giving notice under Section 24.1 and 24.4 is the Contractor, then the Province will as soon as reasonably practicable, notify the Contractor whether or not the Province is satisfied, in the Province's sole discretion, that the matter described in the notice constitutes an event of Force Majeure described in Section 1.1, and the Province's notice will be final and binding.
- 24.6** If the party giving notice under Sections 24.1 and 24.4 is the Province, or if the Province has notified the Contractor under Section 24.4 that the matter described in the Contractor's notice constitutes an event of Force Majeure described in Section 1.1, then the Contractor will enter into good faith negotiations with the Province with a view to resolve the event of Force Majeure and to resume, with the least possible delay, the performance of this Agreement, and notwithstanding the provisions of Section 24.2(b), the Province will not be obliged to make any payments to the Contractor in connection with this Agreement during the period that such event of Force Majeure is continuing.

25. NOTICES

25.1 Any notices hereunder will be in writing and may be given or made by personal delivery, email or courier to the party to whom it is to be given or made, or by mailing in Canada with postage prepaid addressed:

(a) if to the Province:

Ministry of Transportation and Infrastructure

Suite 310 – 1500 Woolridge Street

Coquitlam, BC V3K 0B8

Email Address: Maziar.Kazemi@gov.bc.ca

Attention: Maziar Kazemi

and

Ministry of Transportation and Infrastructure

Email: TRAN.ElectricalandITSDrawings@gov.bc.ca

Attention: Electrical & ITS Engineering

(b) if to the Contractor:

@@Company Name

@@Address

Email Address: @@

Attention: @@

or such other contact and address as may be notified in writing by either party to the other from time to time during the Term;

and any such notice if e-mailed is deemed to have been given, made and received when the e-mail is capable of being retrieved by the addressee, and if mailed in Canada is deemed given to and received by the addressee on the third Working Day after the mailing of the same except in the event of disruption of postal services in Canada in which case any such notice will be deemed given to and received by the addressee when actually delivered to the particular address set out above.

26. JOINT AND SEVERAL LIABILITY AND GUARANTEE RE JOINT VENTURES

26.1 If the Contractor is a joint venture member, each joint venture member comprising the joint venture:

(a) shall be jointly and severally liable for,

(b) shall cause the performance of and compliance with, and

(c) hereby unconditionally and irrevocably guarantees,

the representations, warranties, covenants, obligations and agreements of the Contractor that are made, given or incurred by the Contractor, or to which the Contractor is otherwise subject, under, pursuant to, or as a result of or arising from this Agreement notwithstanding the nature of the legal relationship between the respective joint venture members.

27. MISCELLANEOUS

27.1 Any public announcement relating to the award or entry into this Agreement, as well as media relations that require a collaborative effort between the Parties under this Agreement and between the Parties and government agencies and other organizations shall be arranged by the Province in consultation with the Contractor.

- 27.2 The Contractor will treat as confidential and will not, without the prior written consent of the Province, publish, release, or disclose, or permit to be published, released or disclosed either before or after the expiration or sooner termination of this Agreement, any information, supplied to, obtained by, or which comes to the knowledge of the Contractor as a result of this Agreement, except insofar as such publication, release or disclosure is required by law or is necessary to enable the Contractor to fulfill the obligations of the Contractor under this Agreement.
- 27.3 The Contractor will not, during the Term, perform a service for or provide advice to any person, firm or corporation or other legal entity where the performance of the service or the provision of the advice may or does, in the reasonable opinion of the Province, give rise to a conflict of interest between the obligations of the Contractor to the Province under this Agreement and the obligations of the Contractor to such other person, firm or corporation or other legal entity.
- 27.4 This Agreement constitutes the entire agreement between the Parties in respect of the subject matter of this Agreement and no understandings, representations, contracts, or agreements, oral or otherwise, exist between the Parties with respect to the subject matter of this Agreement except as expressly set out in this Agreement. The Contractor agrees that in entering into this Agreement the Contractor has not and does not rely upon any previous representation of the Province, or of servants, employees, agents, or representatives of the Province, whether expressed or implied, or upon any inducement or agreement of any kind or nature. All prior understandings, negotiations, representations, contracts or agreements are hereby canceled.
- 27.5 Upon the request of the other, each party will make, do, execute or deliver to each other any other reasonable documents, instruments and assurances and do any other reasonable acts required to carry out the true intent and meaning of this Agreement.
- 27.6 Neither the Province nor the Contractor will take advantage of any apparent discrepancy, ambiguity, error, or omission in this Agreement and will notify the other party forthwith following the detection of anything it suspects may be an ambiguity, discrepancy, error, or omission.
- 27.7 Public disclosure of this Agreement and any documents or other records pertaining to this Agreement or those agreements which are in the custody or under the control of the Province, will be governed by the *Freedom of Information and Protection of Privacy Act*, R.S.B.C. 1996, c.165.
- 27.8 Time will be of the essence of this Agreement.
- 27.9 All provisions of this Agreement in favour of the Province and all rights and remedies of the Province, either at law or in equity, will survive the expiration or sooner termination of this Agreement.
- 27.10 This Agreement will enure to the benefit of and be binding upon the Province and its assigns and Contractor and its successors and permitted assigns.
- 27.11 No waiver by either party of a breach or default by the other party in the observance, performance or compliance of any of its obligations under this Agreement will be effective unless it is in writing and no such waiver will be deemed or construed to be a waiver of any other breach or default and failure or delay on the part of either party to complain of an act or failure of the other party or to declare such other party in default, irrespective of how long such failure or delay continues, will not constitute a waiver by such party of any of its rights against the other party.
- 27.12 If any provision of this Agreement or the application thereof to any person or circumstance is invalid or unenforceable to any extent, the remainder of this Agreement and the application of such provision to any other person or circumstance will not be affected or impaired thereby and will be valid and enforceable to the extent permitted by law.
- 27.13 This Agreement may only be amended by a further written agreement executed by both parties.

- 27.14 The Contractor will use its best efforts to adopt electronic modes of communication and transfer of information in formats and through modes of communication specified by the Province.
- 28. INTERPRETATION**
- 28.1 A reference in this Agreement:
- (a) to a statute whether or not that statute has been defined, means a statute of the Province of British Columbia unless otherwise stated and includes every amendment to it, every regulation made under it and any enactment passed in substitution therefore or in replacement thereof; and
 - (b) to any other agreement between the Parties means that other agreement as it may be amended from time to time by the Parties.
- 28.2 Unless the context otherwise requires, any reference to "this Agreement" means this instrument, all of the Schedules attached to it and all documents, manuals or publications referenced in the Schedules and any reference in this Agreement to any article, section, subsection or paragraph by number is a reference to the appropriate article, section, subsection or paragraph in this Agreement.
- 28.3 The headings or captions in this Agreement are inserted for convenience only and do not form a part of this Agreement and in no way define, limit, alter or enlarge the scope or meaning of any provision of this Agreement.
- 28.4 In this Agreement, "person" includes a corporation, firm, association and any other legal entity and wherever the singular or masculine is used it will be construed as if the plural, the feminine or the neuter, and wherever the plural or the feminine or the neuter is used it will be construed as the singular or masculine, as the case may be, had been used where the context or the Parties so require.
- 28.5 Each Schedule attached to this Agreement is an integral part of this Agreement as if set out at length in the body of this Agreement.
- 28.6 For the purposes of this Agreement, the "Contract Documents" will consist of the following documents:
- (a) the Agreement (including but not limited to the Specifications); and
 - (b) the particular provisions of any manuals, drawings and publications referred to in the Agreement.
- 28.7 Conflicts among provisions to this Agreement will be resolved in the following prioritized order:
- (a) amending agreements and Province notices, in reverse chronological order;
 - (b) the provisions of the main body of this Agreement;
 - (c) the Local Area Specifications
 - (d) the General Specifications; and
 - (e) the remaining Schedules.
- 28.8 In this Agreement, the words "including" and "includes", when following any general term or statement, are not to be construed as limiting the general term or statement to the specific items or matters set forth or to similar items or matters, but rather as permitting the general term or statement to refer to all other items or matters that could reasonably fall within the broadest possible scope of the general term or statement.

- 28.9** All dollar amounts expressed in this Agreement refer to lawful currency of Canada, exclusive of GST and inclusive of all other applicable taxes, duties and other charges.
- 28.10** This Agreement will be governed by, construed and interpreted in accordance with the laws of the Province of British Columbia and the courts of competent jurisdiction within the province of British Columbia, will have exclusive jurisdiction with respect to any legal proceedings between the Province and the Contractor arising out of this Agreement.
- 28.11** The Schedules that will form an integral part of this Agreement and are attached hereto, are as follows:
- Schedule 1 Specifications
 - Schedule 2 Local Area Specifications
 - Schedule 3 Electrical Service Area (Map Reference)
 - Schedule 4 Inventory
 - Schedule 5 Fee
 - Schedule 6 Cost for Changes to Inventory
 - Schedule 7 Annual Adjustment Process
 - Schedule 8 Additional Services
 - Schedule 9 Prime Contractor Designation
 - Schedule 10 Dispute Resolution Protocol
 - Schedule 11 Equipment Fleet Operations Policy
 - Schedule 12 Repeater System
 - Schedule 13 Provincial Material List
 - Schedule 14 Bonds
 - Schedule 15 Insurance
 - Schedule 16 Insurance & Securities (Renewal Term)
 - Schedule 17 Privacy Protection
 - Schedule 18 Contractor Details
 - Schedule 19 Tax Verification

SCHEDULE 1 – SPECIFICATIONS

1. DEFINITIONS

1.1 The following terms where used in the Specifications have the following meanings:

“**Corrective Maintenance**” means to repair or replace Inventory so that it is operational and functions without Deficiencies, and in accordance with section 2.1(b) of Specification E-001.

“**Deficiency**” or “**Deficiencies**” means any condition or conditions of an item of Inventory that constitutes or results in a failure to operate in accordance with the Design, Ministry Standards or manufacturer’s specifications, or indicates the item of Inventory is not structurally sound.

“**Design**” means a design of electrical transportation infrastructure, including specific functions, operating characteristics, and settings.

“**Electric Vehicle Charging Station (EVCS)**” means an item of Inventory that supplies electric energy for the recharging of plug-in electric vehicles.

“**HID**” means High Intensity Discharge.

“**Ministry Standards**” means the references and design standards set out in section 2.1 of this Schedule 1.

“**Not Operating**” means, with respect to a light fixture, that 20% or more of the light sources are failing to illuminate or are not illuminating to the manufacturer’s specifications.

“**Patrol**” means the visual inspection of Inventory to verify it is operational and functions without Deficiencies.

“**Preventative Maintenance**” means maintenance performed to reduce the likelihood of Deficiencies occurring. Preventative Maintenance includes but is not limited to:

- tightening mounting hardware and replacing hardware if damaged;
- checking grounding;
- lubricating hinges, locks, latches and bolts;
- cleaning lenses, reflectors, housings, etc. and replacing if damaged;
- cleaning luminaire enclosures;
- cleaning signs;
- checking Inventory for proper alignment and visibility;
- repairing leaks;
- removing rust, painting if rusted;
- checking cable splices;
- replacing air filters
- documenting maintenance activity; and
- recording deficiencies and damage not immediately repaired.

“**Remote**” means a distance greater than 250km by road one-way from a Base Location.

“**Repair Time**” means the length of time between the time the Contractor detects or becomes aware of the condition of an item of Inventory requiring Corrective Maintenance, and the completion of Corrective Maintenance for that item of Inventory.

“**Response Time**” means the length of time between the time the Contractor becomes aware of the condition of an item of Inventory requiring Corrective Maintenance, and the commencement of work

to assess, plan and where required travel from the nearest Base Location to the site to perform Corrective Maintenance for that item of Inventory.

“**Risk to Public Safety**” includes any reduction in the level of safety to the public compared to the level of safety provided by the relevant Inventory if functioning without Deficiencies.

“**Traffic Disruption**” means a change from the typical flow of traffic at the location of the item of Inventory concerned.

And any other word or capitalized word or phrase will have the meaning ascribed in Section 1.1 of this Agreement.

2. REFERENCES AND DESIGN STANDARDS

2.1 The following documents, as may be amended from time to time by the Ministry, contain the requirements for the carrying out of any of the Routine Maintenance Services or Additional Services:

- Traffic and Electrical Engineering Manual
- Traffic and Electrical Technical Bulletins
- Electrical and Signing Materials Standards
- Traffic Controller Design Manual
- Traffic Controller Assembly Manual Volume 1 and 2
- LMD 8000 Programming Guide
- Naztec Programming Guide
- Cobalt Programming Guide
- Count Station Installation and Maintenance Guidelines
- Recognized Products List

The publications listed above can be found at:

<https://www2.gov.bc.ca/gov/content/transportation/transportation-infrastructure/engineering-standards-guidelines>

- Advanced Traveller Information System maintenance website
<http://www.th.gov.bc.ca/ATIS/lqcws/private.htm>
<http://www.th.gov.bc.ca/ATIS/private.htm>
- AASHTO Guidelines for Traffic Data Programs
<https://trid.trb.org/view/891041>
- Guide for Inspecting and Testing Preemption of Interconnected Traffic Control Signals and Railway Crossing Warning Systems
<http://www.tc.gc.ca/media/documents/railsafety/TP13755.pdf>
- Highways Maintenance Contracts – Maintenance Specifications
<https://www2.gov.bc.ca/gov/content/transportation/transportation-infrastructure/contracting-to-transportation/highway-bridge-maintenance/highway-maintenance/agreement/specifications>

- Local Area Specifications contained within the Highway Maintenance Contracts as they pertain to restrictions on hours of work within the electrical service area.
<https://www2.gov.bc.ca/gov/content/transportation/transportation-infrastructure/contracting-to-transportation/highway-bridge-maintenance/highway-maintenance/agreement/local-area-specifications-las>
- Manual of Standard Traffic Signs and Pavement Markings
https://www2.gov.bc.ca/assets/gov/driving-and-transportation/transportation-infrastructure/engineering-standards-and-guidelines/traffic-engineering-and-safety/traffic-engineering/traffic-signs-and-pavement-markings/manual_signs_pavement_marking.pdf
- Catalogue of Standard Traffic Signs
<https://www2.gov.bc.ca/gov/content/transportation/transportation-infrastructure/engineering-standards-guidelines/traffic-engineering-safety/traffic-signs-markings#catalogue>
- Pedestrian Crossing Control Manual for British Columbia
<https://www2.gov.bc.ca/gov/content/transportation/transportation-infrastructure/engineering-standards-guidelines/traffic-engineering-safety/pedestrian-crossing>
- Specifications for Standard Highway Sign Materials, Fabrication and Supply
https://www2.gov.bc.ca/assets/gov/driving-and-transportation/transportation-infrastructure/engineering-standards-and-guidelines/traffic-engineering-and-safety/traffic-engineering/traffic-signs-and-pavement-markings/standard-traffic-signs/specifications/sign_fabrication_specs.pdf
- Traffic Management Guidelines
<https://www2.gov.bc.ca/gov/content/transportation/transportation-infrastructure/engineering-standards-guidelines/traffic-engineering-safety/trafficmanagementmanual>
- Standard Specifications for Highway Construction (Current Edition)
<https://www2.gov.bc.ca/gov/content/transportation/transportation-infrastructure/engineering-standards-guidelines/standard-specifications-for-highway-construction>
- DriveBC
<http://www.drivebc.ca/>
- DriveBC Input Tool User Guide.
Request access to the DriveBC input tool and supporting documentation by email to:
tranit@gov.bc.ca
- Radio Call Book
Contractor to obtain current Radio Call Books from Ministry Representative

2.2 All Inventory must be maintained to at least the requirements set out in the Ministry Standards, and any manufacturer's specifications or operations manuals. In the case of any conflict between such

manufacturer's specifications or operation manuals and the present Specifications, the present Specifications must apply.

3. MATERIALS

3.1 Contractor supplied materials must conform with the Ministry Electrical and Signing Materials Standards and the Recognized Products List.

3.2 If any of the following items must be or are proposed to be replaced by the Contractor, the Contractor will first obtain the approval of the Ministry for such replacement, and the Ministry will reimburse the Contractor for the cost of the device or provide that item to the Contractor at the Ministry's cost:

- a) 69KV transformer or its component parts;
- b) traffic controller assembly;
- c) web camera;
- d) solar power batteries having a capacity of greater than 600 amp-hours per cell;
- e) speed feedback sign;
- f) electronic messaging sign;
- g) vehicle charge-cable for Electric Vehicle Charging Stations;
- h) LED message sign display module;
- i) LED chevron sign;
- j) communication and networking equipment, unless otherwise specified in the local area specifications;
- k) overhead sign; and
- l) other devices as may be determined by the Ministry in its sole discretion.

3.3 All removed and/or replaced components of Inventory including but not limited to steel, wire, concrete, lamps, batteries and plastic are to be disposed of in an environmentally appropriate manner and, if possible, materials will be recycled.

4. INTERPRETATION, RESPONSE TIMES AND REPAIR TIMES

4.1 Whenever a Response Time is specified for Services in these Specifications, the Contractor must begin Services within the specified time and diligently proceed with the Services until completed. Whenever a Repair Time is specified for Services in these Specifications, the Contractor must complete the Services within the specified time.

4.2 Where multiple Response Times or Repair Times set out in these Specifications apply to an obligation of the Contractor, the Contractor must perform the obligation within the applicable Response Time or Repair Time as directed by the Ministry.

4.3 Whenever more than one Specification, whether in whole or in part, applies to a particular location, condition, circumstance or activity, the Contractor shall comply with each and every applicable Specification or part of a Specification, as the case may be.

4.4 Any obligation of the Contractor to perform Corrective Maintenance that has no other Response Time or Repair Time set out in these Specifications, shall have a Response Time as directed by the Ministry.

INDEX - ELECTRICAL MAINTENANCE SPECIFICATIONS

000 GENERAL

E-001 REQUIREMENTS APPLICABLE TO ALL SPECIFICATIONS

100 SIGNALS

E-110 TRAFFIC AND PEDESTRIAN SIGNAL MAINTENANCE

E-120 OVERHEAD FLASHING BEACON MAINTENANCE

E-130 TEMPORARY ONE-WAY BRIDGE SIGNAL MAINTENANCE

E-140 FIRE SIGNAL MAINTENANCE

200 FLASHERS

E-210 POST MOUNTED FLASHER MAINTENANCE

E-220 OVERHEAD WARNING SIGNS WITH FLASHERS MAINTENANCE

E-230 SOLAR POWERED FLASHER MAINTENANCE

300 LIGHTING

E-310 STREET, ROADWAY, AREA AND SIGN LIGHTING MAINTENANCE

E-320 HIGHMAST LIGHTING MAINTENANCE

E-330 TUNNEL AND SNOWSHED LIGHTING MAINTENANCE

E-340 PEDESTRIAN AND CYCLIST TUNNEL LIGHTING MAINTENANCE

E-350 ARCHITECTURAL AND ORNAMENTAL LIGHTING MAINTENANCE

E-360 AVIATION, NAVIGATIONAL AND PIER LIGHTING MAINTENANCE

400 MISCELLANEOUS

E-410 SHORT DURATION TRAFFIC COUNT STATION MAINTENANCE

E-420 PERMANENT TRAFFIC COUNT STATION MAINTENANCE

E-430 UNINTERRUPTIBLE POWER SUPPLY MAINTENANCE

E-440 WEB CAMERA MAINTENANCE

E-450 SOLAR POWERED WEB CAMERA MAINTENANCE

E-460 BLUETOOTH READER MAINTENANCE

E-470 WEIGH SCALES MAINTENANCE

E-480 REST AREA WI-FI POWER MAINTENANCE

E-490 SOLAR POWERED UNIT MAINTENANCE

500 ELECTRONIC SIGNS

E-510 LED AND FLIP DISK DYNAMIC MESSAGE SIGN MAINTENANCE

E-520 ACTUATED RAILWAY WARNING SIGN MAINTENANCE

INDEX - ELECTRICAL MAINTENANCE SPECIFICATIONS *(CONTINUED)*

E-530..... ILLUMINATED PEDESTRIAN CROSSING SIGN AND SPECIAL CROSSWALK SIGN MAINTENANCE

E-540..... HIGHWAY OPEN/CLOSED SIGN MAINTENANCE

E-550..... LED CHEVRON SIGN MAINTENANCE

E-560..... SPEED FEEDBACK SIGN MAINTENANCE

E-570..... LED W-064 WATCH FOR WILD ANIMALS SIGN MAINTENANCE

600 SYSTEMS

E-610..... OVER-HEIGHT DETECTION SYSTEM MAINTENANCE

E-640..... ELECTRIC VEHICLE CHARGING STATION MAINTENANCE

900 PROCEDURES

E-910..... ELECTRICAL INFRASTRUCTURE INCIDENT AND VANDALISM RESPONSE

E-920..... TRAFFIC CONTROLLER EQUIPMENT DISPOSAL

E-930..... ELECTRICAL PATROL

ELECTRICAL MAINTENANCE SPECIFICATION E-001
APPLICABLE TO ALL SPECIFICATIONS

1. OBJECTIVE

This specification is of general application to and applies to all electrical maintenance specifications in Schedule 1 and Schedule 2 with regard to the provision of Services.

2. DETAILED PERFORMANCE SPECIFICATIONS

2.1 Routine Maintenance Services

The Contractor must:

- a) perform Corrective Maintenance to repair or replace Inventory that constitutes, or has the potential to constitute, a Risk to Public Safety, or cause a Traffic Disruption, or is not structurally sound and proceed diligently with the work until completed. In the case of a Traffic Disruption, input to DriveBC a summary of the Traffic Disruption and update DriveBC with any changes to the Traffic Disruption.

Response Time: Immediate;

- b) perform Corrective Maintenance for any condition of an item of Inventory that is not otherwise addressed in the Specifications but creates or has the potential to create issues or problems for its operation or functioning, or to address any condition of an item of Inventory which the Ministry has directed the Contractor to address.

Repair Time: 30 days, unless otherwise agreed in writing by the Ministry;

- c) Preventative Maintenance must be performed on every item of Inventory at least once every 12 months;
- d) remove or cover graffiti in accordance with the performance time frames listed in the Highway Maintenance Specification – Litter Collection and Graffiti Removal; and,
- e) document all activities related to electrical maintenance of the Inventory including but not limited to field inspections, Patrols, testing, complaints received, responses made, and any changes made to the infrastructure in a timely manner, to the Ministry's satisfaction.

2.2 Materials

- a) Refer to Article 3 of the Introduction to the Specifications.

**ELECTRICAL MAINTENANCE SPECIFICATION E-110
TRAFFIC AND PEDESTRIAN SIGNALS MAINTENANCE**

1. OBJECTIVE

Traffic and pedestrian signals of all types are to operate and function without Deficiencies.

2. DETAILED PERFORMANCE SPECIFICATIONS

2.1 Routine Maintenance Services

In addition to Electrical Maintenance Specification E-001, the Contractor must:

- a) repair or replace traffic and pedestrian signals and their components, except detection loops, with Deficiencies.

Repair Time: 24 hours;

- b) replace signal head lights that are Not Operating.

Repair Time: 24 hours;

- c) repair or replace traffic signal detection loops with Deficiencies.

Repair Time: 7 days;

- d) test conflict monitors once every 12 months;

- e) implement traffic signal timing plans as per section 500 of the Traffic Controller Design Manual up to a maximum number of 100% of the pedestrian and traffic signal Inventory total per Contract Year as follows:

(i) where required when the traffic controller is installed, replaced, or modified:
complete within 14 days of being provided notice by the Ministry or its contractors;

(ii) where required due to traffic signal timing Deficiencies:
complete within 12 hours of receiving the traffic signal timing plans from the Ministry or its contractors;

(iii) where required due to scheduled roadway maintenance or construction activities by others:
complete within 7 days of being provided notice by the Ministry or its contractors;

(iv) all other traffic signal timing plan updates:
complete within 21 days of receiving the traffic signal timing plans from the Ministry or its contractors;

- f) collect controller volume and measure of effectiveness (MOE) logs as requested by the Ministry following the guidelines outlined in section 500 of the Traffic Controller Design Manual up to a maximum of 60% of the pedestrian and traffic signal Inventory total per Contract Year as follows:
 - (i) for 5 locations:
complete within 24 hours of being provided notice by the Ministry or its contractors;
 - (ii) for the remainder of the 60%:
complete within 14 days of being provided notice by the Ministry or its contractors;
- g) immediately advise the railway authority, and the Ministry Representative if the traffic signal preemption system at a railway crossing is not functioning in accordance with its Design, Ministry Standards, and manufacturer's specifications;
- h) contact the local government and jointly test in the field the operation of the emergency signal preemption sensors at every railway crossing, once every twelve months;
- i) test all traffic, railway, and emergency signal and transit preemption systems by using the "local" setting in the controller cabinet preemption cards and testing each direction of preemption to ensure operation in accordance with its Design, Ministry Standards and manufacturer's specifications, once every twelve months; and,
- j) contact the railway authority and arrange to jointly test in the field the operation of any railway preemption or railway advance-warning sign system, including but not limited to signal timing sequences, at every railway crossing, once every twelve months.

ELECTRICAL MAINTENANCE SPECIFICATION E-120
OVERHEAD FLASHING BEACON MAINTENANCE

1. OBJECTIVE

Overhead flashing beacons are to operate and function without Deficiencies.

2. DETAILED PERFORMANCE SPECIFICATIONS

2.1 Routine Maintenance Services

In addition to Electrical Maintenance Specification E-001, the Contractor must:

- a) repair or replace overhead flashing beacons and their components with Deficiencies.
Repair Time: 24 hours;
- b) replace all signal head lights that are Not Operating.
Repair Time: 24 hours; and,
- c) replace all non-LED signal head lamps once every 12 months.

ELECTRICAL MAINTENANCE SPECIFICATION E-130
TEMPORARY ONE-WAY BRIDGE SIGNAL MAINTENANCE

1. OBJECTIVE

Temporary one-way bridge signals are to operate and function without Deficiencies

2. DETAILED PERFORMANCE SPECIFICATIONS

2.1 Routine Maintenance Services

In addition to Electrical Maintenance Specification E-001, the Contractor must:

- a) repair or replace temporary one-way bridge signals and their components with Deficiencies.
Repair Time: 24 hours;
- b) replace all signal head lights that are Not Operating.
Repair Time: 24 hours;
- c) replace all non-LED signal head lamps once every 12 months;
- d) test all conflict monitors once every 12 months;
- e) store and maintain the Ministry supplied temporary one-way bridge signal controller assembly including but not limited to providing, maintaining and servicing UPS batteries to enable the unit to be deployed within 7 days;
- f) implement temporary one-way bridge signal timing plans as per section 500 of the *Traffic Controller Design Manual* as follows:
 - (i) where required for new temporary one-way bridge signals or modifications to existing signals:
complete within 14 days of being provided notice by the Ministry or its contractors;
 - (ii) where required due to one-way bridge signal timing Deficiencies:
complete within 12 hours of receiving the traffic signal timing plans from the Ministry or its contractors;
 - (iii) where required due to scheduled roadway maintenance or construction activities by others:

complete within 7 days of being provided notice by the Ministry or its contractors;
 - (iv) all other one-way bridge signal timing plan updates:

complete within 21 days of receiving the new temporary one-way bridge traffic signal timing plans from the Ministry or its contractors; and

- g) collect controller volume and measure of effectiveness (MOE) logs as requested by the Ministry following the guidelines outlined in section 500 of the *Traffic Controller Design Manual*.

2.2 Materials

For new traffic signal controller installations, the Ministry will supply a complete unit as per the design requirements.

ELECTRICAL MAINTENANCE SPECIFICATION E-140
FIRE SIGNAL MAINTENANCE

1. OBJECTIVE

Fire signals are to operate and function without Deficiencies.

2. DETAILED PERFORMANCE SPECIFICATIONS

2.1 Routine Maintenance Services

In addition to Electrical Maintenance Specification E-001, the Contractor must:

- a) repair or replace fire signals and their components with Deficiencies.
Repair Time: 24 hours;
- b) replace all signal head lights that are Not Operating.
Repair Time: 24 hours;
- c) replace all non-LED signal head lamps once every 12 months;
- d) test all conflict monitors once every 12 months; and,
- e) meet on site with fire department staff to confirm operation once every 12 months and as required.

ELECTRICAL MAINTENANCE SPECIFICATION E-210
POST MOUNTED FLASHER MAINTENANCE

1. OBJECTIVE

Post mounted flashers are to operate and function without Deficiencies.

2. DETAILED PERFORMANCE SPECIFICATIONS

2.1 Routine Maintenance Services

In addition to Electrical Maintenance Specification E-001, the Contractor must:

- a) repair or replace post mounted flashers and their components with Deficiencies.

Repair Time: 7 days;

- b) replace signal head lights that are Not Operating.

Repair Time: 7 days; and,

- c) replace all non-LED lamps of signal heads once every 12 months.

**ELECTRICAL MAINTENANCE SPECIFICATION E-220
OVERHEAD WARNING SIGNS WITH FLASHERS MAINTENANCE**

1. OBJECTIVE

Overhead warning signs with flashers are to operate and function without Deficiencies.

2. DETAILED PERFORMANCE SPECIFICATIONS

2.1 Routine Maintenance Services

In addition to Electrical Maintenance Specification E-001, the Contractor must:

- a) repair or replace overhead warning signs with flashers and their components with Deficiencies;
Repair Time: 24 hours;
- b) replace all signal head lights that are Not Operating.
Repair Time: 24 hours;
- c) replace HID lamps once every 48 months; and,
- d) replace non-LED lamps (except HID) once every 12 months.

ELECTRICAL MAINTENANCE SPECIFICATION E-230
SOLAR POWERED FLASHER MAINTENANCE

1. OBJECTIVE

Solar powered flashers are to operate and function without Deficiencies.

This specification addresses solar powered flashers used in overhead warning signs, overhead beacons, post-mounted flashers, cross-walks, and any other devices that use solar energy to power flashers.

2. DETAILED PERFORMANCE SPECIFICATIONS

2.1 Routine Maintenance Services

In addition to Electrical Maintenance Specification E-001, the Contractor must:

- a) repair or replace solar powered flashers with Deficiencies.

Repair Time: 7 days;

- b) in addition to Preventative Maintenance as stated in E-001, perform the following:

- (i) test batteries and replace when their capacity falls below 80% of the rated 20-hour capacity;
- (ii) replace any battery with electrolyte leakage;
- (iii) clean terminals of any corrosion;
- (iv) torque terminal fasteners to manufacturer's specification;
- (v) clean solar panels;
- (vi) confirm operation of the solar charge controller as per manufacturer's specifications;
and,
- (vii) confirm cable splices are sound and environmentally protected.

ELECTRICAL MAINTENANCE SPECIFICATION E-310
STREET, ROADWAY, AREA, AND SIGN LIGHTING MAINTENANCE

1. OBJECTIVE

Street, roadway, area and sign lighting are to operate and function without Deficiencies.

2. DETAILED PERFORMANCE SPECIFICATIONS

2.1 Routine Maintenance Services

In addition to Electrical Maintenance Specification E-001, the Contractor must:

a) repair or replace luminaires when:

- (i) 50% or more of the luminaires at a signalized or un-signalized intersection, interchange, or roadway between interchanges or intersections are Not Operating; or,
- (ii) any luminaire directly over a marked pedestrian crossing is Not Operating; or,
- (iii) 3 adjacent luminaires are Not Operating.

Repair Time: 24 hours;

b) repair or replace luminaires when:

- (i) less than 50% of the luminaires at a signalized or un-signalized intersection, interchange or roadway between interchanges or intersections, signalized pedestrian crossing, or areas of continuous lighting are Not Operating; or,
- (ii) 2 adjacent luminaires are Not Operating; or
- (iii) warning sign luminaires are Not Operating.

Repair Time: 7 days

- c) mark all installed or replaced HID lamps with the date at the time of installation or replacement;
- d) replace all HID street, roadway, area, and sign lighting lamps every 48 months with 25% being replaced each year;
- e) document the make, model, location, and installation date of newly installed or replacement LED roadway lighting fixtures; and,
- f) clean lenses and remove accumulated dirt build-up from 25% of LED roadway, area, and sign fixtures every twelve months, so that all LED fixtures are cleaned once every 48 months.

ELECTRICAL MAINTENANCE SPECIFICATION E-320
HIGH-MAST LIGHTING MAINTENANCE

1. OBJECTIVE

High-mast lighting is to operate and function without Deficiencies.

2. DETAILED PERFORMANCE SPECIFICATIONS

2.1 Routine Maintenance Services

In addition to Electrical Maintenance Specification E-001, the Contractor must:

- a) repair or replace high-mast lighting and/or their components if more than 50% of the luminaires are Not Operating on one pole.

Repair Time: 24 hours;

- b) repair or replace high-mast lighting and/or their components if 50% or less of the luminaires are Not Operating on one pole.

Repair Time: 7 days;

- c) replace high-mast lighting HID lamps once every 48 months;

- d) mark all installed or replaced HID lamps with the date at the time of replacement or installation;

- e) document the make, model, location, and installation date of newly installed or replacement LED high-mast lighting fixtures;

- f) clean lenses and remove accumulated dirt build-up from fixture housings once every 12 months; and,

- g) service, and inspect raise / lower systems once every 12 months.

**ELECTRICAL MAINTENANCE SPECIFICATION E-330
TUNNEL AND SNOWSHED LIGHTING MAINTENANCE**

1. OBJECTIVE

Tunnel and snow-shed lighting is to operate and function without Deficiencies.

2. DETAILED PERFORMANCE SPECIFICATIONS

2.1 Routine Maintenance Services

In addition to Electrical Maintenance Specification E-001, the Contractor must:

a) repair or replace tunnel and snow-shed lighting and/or their components when:

- (i) three adjacent luminaires on a day or night circuit are Not Operating; or,
- (ii) any of the luminaires on an emergency circuit, are Not Operating.

Repair Time: 24 hours;

b) repair or replace tunnel and snow-shed lighting and/or their components if two adjacent luminaires on an emergency/night circuit are Not Operating.

Repair Time: 7 days;

e) replace tunnel and snow-shed lighting HID lamps once every 48 months;

f) mark installed or replaced HID lamps with the date at the time of replacement or installation;

g) document the make, model, location, and installation date of newly installed or replacement LED lighting fixtures; and,

h) clean tunnel and snow-shed lighting luminaires once every 6 months.

ELECTRICAL MAINTENANCE SPECIFICATION E-340
PEDESTRIAN AND CYCLIST TUNNEL LIGHTING MAINTENANCE

1. OBJECTIVE

Pedestrian and cyclist tunnel lighting is to operate and function without Deficiencies.

2. DETAILED PERFORMANCE SPECIFICATIONS

2.1 Routine Maintenance Services

In addition to Electrical Maintenance Specification E-001, the Contractor must:

- a) repair or replace pedestrian and cyclist tunnel lighting and/or their components if two adjacent luminaires, or if more than 50% of the luminaires in the tunnel, are Not Operating.

Repair Time: 24 hours;

- b) repair or replace pedestrian and cyclist tunnel lighting and/or their components if 50% or less are Not Operating.

Repair Time: 7 days;

- c) replace all pedestrian and cyclist tunnel lighting HID lamps once every 48 months;

- d) replace all non-LED lamps (except HID) once every 12 months;

- e) clean lenses and remove accumulated dirt build-up from housing of pedestrian and cyclist tunnel fixtures once every 12 months;

- f) mark all installed or replaced HID lamps with the date at the time of replacement or installation; and,

- g) document the make, model, location, and installation date of newly installed or replaced LED fixtures.

ELECTRICAL MAINTENANCE SPECIFICATION E-350
ARCHITECTURAL AND ORNAMENTAL LIGHTING MAINTENANCE

1. OBJECTIVE

Architectural and ornamental lighting is to operate and function without Deficiencies.

2. DETAILED PERFORMANCE SPECIFICATIONS

2.1 Routine Maintenance Services

In addition to Electrical Maintenance Specification E-001, the Contractor must:

- a) repair or replace architectural and ornamental lighting and their components if 3 adjacent luminaires, or if more than 50% of the luminaires in an installation, are Not Operating.

Repair Time: 7 days;

- b) replace HID lamps once every 48 months;
- c) replace all non-LED lamps (except HID) lamps once every 12 months;
- d) mark all installed and replaced lamps with the date at the time of replacement or installation;
and,
- e) document make, model, location and installation date of newly installed or replacement LED architectural and ornamental lighting fixtures;

ELECTRICAL MAINTENANCE SPECIFICATION E-360
AVIATION, NAVIGATIONAL AND PIER LIGHTING MAINTENANCE

1. OBJECTIVE

Aviation lighting, navigational lighting and pier lighting is to operate and function without Deficiencies.

2. DETAILED PERFORMANCE SPECIFICATIONS

2.1 Routine Maintenance Services

In addition to Electrical Maintenance Specification E-001, the Contractor must:

- a) repair or replace aviation, navigational and pier lighting and their components with Deficiencies.

Repair Time: 24 hours;

- b) replace HID lamps once every 48 months;
- c) replace non-LED lamps (except HID) once every 12 months;
- d) mark all installed and replaced lamps with the date at the time of replacement or installation;
and,
- e) document make, model, location and installation date of newly installed or replacement LED fixtures.

ELECTRICAL MAINTENANCE SPECIFICATION E-410
SHORT DURATION TRAFFIC COUNT STATION MAINTENANCE

1. OBJECTIVE

Short duration traffic count stations are to operate and function without Deficiencies.

2. DETAILED PERFORMANCE SPECIFICATIONS

2.1 Routine Maintenance Services

In addition to Electrical Maintenance Specification E-001, the Contractor must:

- a) repair or replace short duration traffic count stations and their components with Deficiencies.
Repair Time: 30 days;
- b) perform condition assessments of short duration traffic count stations as per the *Count Station Installation and Maintenance Guidelines* manual, and submit the assessment reports to the Ministry Representative, for 30 locations each Contract Year; and,
- c) collect short count volumes from short duration traffic count stations, for 10 locations per Contract Year;

ELECTRICAL MAINTENANCE SPECIFICATION E-420
PERMANENT TRAFFIC COUNT STATION MAINTENANCE

1. OBJECTIVE

Permanent traffic count stations are to operate and function without Deficiencies.

A permanent count station is defined in the *AASHTO Guidelines for Traffic Data Programs, 2009* as a permanently installed counting or measuring device that is intended to operate continuously through-out the year.

2. DETAILED PERFORMANCE SPECIFICATIONS

2.1 Routine Maintenance Services

In addition to Electrical Maintenance Specification E-001, the Contractor must:

- a) repair or replace permanent traffic count stations and their components (except traffic count loops) with Deficiencies.

Repair Time: 14 days;

- b) repair or replace failed traffic count detector loops.

Repair Time: 30 days; and,

- c) perform preventative maintenance as per the *Count Station Installation and Maintenance Guideline Manual* once every 12 months.

ELECTRICAL MAINTENANCE SPECIFICATION E-430
UNINTERRUPTIBLE POWER SUPPLY MAINTENANCE

1. OBJECTIVE

Uninterruptible power supplies (UPS) are to operate and function without Deficiencies.

2. DETAILED PERFORMANCE SPECIFICATIONS

2.1 Routine Maintenance Services

In addition to Electrical Maintenance Specification E-001, the Contractor must:

- a) repair or replace UPS and their components with Deficiencies.

Repair Time: 24 hours; and,

- b) test batteries once every 6 months and replace if their capacity falls below 80% of their 20-hour rated capacity;

ELECTRICAL MAINTENANCE SPECIFICATION E-440
WEB CAMERA MAINTENANCE

1. OBJECTIVE

Web cameras are to operate and function without Deficiencies.

2. DETAILED PERFORMANCE SPECIFICATIONS

2.1 Routine Maintenance Services

In addition to Electrical Maintenance Specification E-001, the Contractor must:

- a) repair or replace web cameras and their components with Deficiencies.

Repair Time: 7 Days (14 Days for Remote web cameras);

ELECTRICAL MAINTENANCE SPECIFICATION E-450
SOLAR POWERED WEB CAMERA MAINTENANCE

1. OBJECTIVE

Solar powered web cameras are to operate and function without Deficiencies.

2. DETAILED PERFORMANCE SPECIFICATIONS

2.1 Routine Maintenance Services

In addition to Electrical Maintenance Specification E-001, the Contractor must:

- a) repair or replace solar powered web cameras and their components with Deficiencies.

Repair Time: 7 days (14 days for Remote solar powered web cameras);

- b) in addition to Preventative Maintenance as stated in E-001, perform the following:

- (i) test batteries and replace (or notify Ministry Representative if capacity greater than 600 amp-hours per cell) when their capacity falls below 80% of the rated 20-hour capacity;
- (ii) replace (or notify Ministry Representative if capacity greater than 600 amp-hours per cell) any battery with electrolyte leakage;
- (iii) clean terminals of corrosion;
- (iv) torque terminal fasteners to manufacturers specification;
- (v) clean solar panels;
- (vi) confirm operation of the solar charge controller as per manufacturers specifications and confirm charging parameters are correct for the type, make, and model of battery;
- (vii) repair or replace all cable splices that are not sound and environmentally protected;
- (viii) repair or replace cabling and fittings that have been compromised due to friction, stress, or solar exposure;
- (ix) clean camera housing interior and exterior, housing glass, and camera lens; and,
- (x) check solar panel and antenna mounting brackets to confirm they are structurally sound all fasteners are tight.

ELECTRICAL MAINTENANCE SPECIFICATION E-460
BLUETOOTH READER MAINTENANCE

1. OBJECTIVE

Bluetooth readers are to operate and function without Deficiencies.

2. DETAILED PERFORMANCE SPECIFICATIONS

2.1 Routine Maintenance Services

In addition to Electrical Maintenance Specification E-001, the Contractor must:

- a) repair or replace bluetooth readers and their components with Deficiencies.

Repair Time: 7 days;

ELECTRICAL MAINTENANCE SPECIFICATION E-470
WEIGH SCALES MAINTENANCE

1. OBJECTIVE

Weigh scale electrical infrastructure is to operate and function without Deficiencies.

1.1 Excluded infrastructure

The following equipment is not included in this specification:

- (i) weigh scale building interior lighting
- (ii) weigh scale building exterior lighting mounted on the building
- (iii) weigh scale building power
- (iv) closed circuit television (CCTV) systems;
- (v) weight display signs;
- (vi) weigh in motion (WIM) hardware and computer equipment
- (vii) automatic vehicle inspection (AVI) hardware and station computer equipment
- (viii) weigh2gobc hardware and station computer equipment

2. DETAILED PERFORMANCE SPECIFICATIONS

2.1 Routine Maintenance Services

In addition to Electrical Maintenance Specification E-001, the Contractor must:

- a) repair or replace weigh scale electrical infrastructure and components with Deficiencies.
Repair Time: 24 hours;
- b) restore power and communication for weigh in motion equipment.
Repair Time: 24 hours;
- c) repair or replace the electrical service panel supplying power to electrical infrastructure maintained under this agreement as required;
- d) repair or replace ramp and parking lot lighting in accordance with electrical maintenance specification E-310 and E-320;
- e) repair or replace weigh scale open / closed signs in accordance with electrical maintenance specification E-540; and,
- f) repair or replace electrical components of scale sign-boards (proceed, next axel, etc.) in accordance with electrical maintenance specifications E-540.

ELECTRICAL MAINTENANCE SPECIFICATION E-480
REST AREA WI-FI POWER MAINTENANCE

1. OBJECTIVE

Electrical services to rest area wi-fi systems are to operate and function without Deficiencies.

2. DETAILED PERFORMANCE SPECIFICIATIONS

This specification is for electrical services providing power to wi-fi systems installed at Ministry rest areas. The maintenance of the wi-fi networking and communications equipment, or any of its components, is not within the scope of this specification.

2.1 Routine Maintenance Services

In addition to Electrical Maintenance Specification E-001, the Contractor must:

- a) repair or replace rest area wi-fi electrical power supply infrastructure with Deficiencies.

Repair Time: 7 days; and,

- b) notify the Ministry Representative if rest area wi-fi electrical infrastructure, excluding the power supply infrastructure, has a Deficiency;

ELECTRICAL MAINTENANCE SPECIFICATION E-490
SOLAR POWERED UNIT MAINTENANCE

1. OBJECTIVE

Solar power units used to power electrical infrastructure are to operate and function without Deficiencies.

Solar power unit components include: batteries, solar charge controllers, solar panels, combiners, inverters, connecting cables, cabinets or enclosures, and supporting structures.

2. DETAILED PERFORMANCE SPECIFICATIONS

2.1 Routine Maintenance Services

In addition to Electrical Maintenance Specification E-001, the Contractor must:

- a) repair or replace solar power unit components with Deficiencies.

Repair Time: 7 days;

- b) in addition to Preventative Maintenance as stated in E-001, perform the following:

- (i) test batteries and replace (or notify Ministry Representative if capacity greater than 600 amp-hours per cell) when their capacity falls below 80% of the rated 20-hour capacity;
- (ii) replace (or notify Ministry Representative if capacity greater than 600 amp-hours per cell) any battery with electrolyte leakage;
- (iii) clean terminals of any corrosion;
- (iv) torque terminal fasteners to manufactures specification;
- (v) clean solar panels;
- (vi) confirm operation of the solar charge controller as per manufacturers specifications and ensure charging parameters are correct for the type, make, and model of battery; and,
- (vii) confirm cable splices are sound and environmentally protected.

ELECTRICAL MAINTENANCE SPECIFICATION E-510
LED AND FLIP DISK DYNAMIC MESSAGE SIGN MAINTENANCE

1. OBJECTIVE

LED and Flip-Disk Dynamic Message Signs (DMS) are to operate and function without Deficiencies.

2. DETAILED PERFORMANCE SPECIFICATIONS

2.1 Routine Maintenance Services

In addition to Electrical Maintenance Specification E-001, the Contractor must:

- a) repair or replace DMS and/or their components with Deficiencies.

Repair Time: 7 days;

- b) for LED DMS signs, perform the following pixel test procedure once every 12 months and repair or replace any LED modules that fail:

(i) perform a full pixel test where all pixels of all modules are turned on. If all modules have at most one failed pixel, skip steps ii and iii and proceed to step iv.

(ii) perform the selected character test using largest standard message font: Each LED module shall display the following characters with no failed pixels: A, B, E, K, M, Q, V, Y.

(iii) each character shall be displayed (without spaces) across the entire width of each row of the sign until all letters have been displayed and confirmed to have no pixel failures.

(iv) the test results shall be recorded and stored by the contractor and be made available to the Ministry Representative upon request;

- c) for flip-disk signs, the contractor must repair or replace a sign with Deficiencies to power or communications. For all flip-disk signs, once every 12 months, the Contractor must perform the following test:

(i) a full pixel test where all the modules are turned on. If all modules have at most one failed pixel, the sign is operational; and,

(ii) If more than 1 pixel in a module has failed, repair or replace the module.

If the unavailability of replacement parts makes it impossible to restore normal operation, blank the sign and notify the Ministry Representative.

ELECTRICAL MAINTENANCE SPECIFICATION E-520
ACTUATED RAILWAY WARNING SIGN MAINTENANCE

1. OBJECTIVE

Actuated railway warning signs are to operate and function without Deficiencies.

2. DETAILED PERFORMANCE SPECIFICATIONS

2.1 Routine Maintenance Services

In addition to Electrical Maintenance Specification E-001, the Contractor must:

- a) immediately advise the railway authority and the Ministry Representative if any warning sign is not operational;
- b) repair or replace actuated railway warning signs and their components with Deficiencies.
Repair Time: 24 hours;
- c) replace all lights, including both luminaires and signals, that are Not Operating.
Repair Time: 24 hours;
- d) replace all HID lamps once every 48 months;
- e) replace non-LED lamps (except HID) once every 12 months; and,
- f) contact the railway authority and arrange to jointly test in the field the operation of any railway preemption or railway advance-warning sign system including but not limited to signal timing sequences, once every 12 months.

ELECTRICAL MAINTENANCE SPECIFICATION E-530

ILLUMINATED PEDESTRIAN CROSSING SIGN AND SPECIAL CROSSWALK SIGN MAINTENANCE

1. OBJECTIVE

Illuminated pedestrian crossing signs and special crosswalk signs are to operate and function without Deficiencies.

2. DETAILED PERFORMANCE SPECIFICATIONS

2.1 Routine Maintenance Services

In addition to Electrical Maintenance Specification E-001, the Contractor must:

- a) repair or replace illuminated pedestrian crossing signs and special crosswalk signs and their components with Deficiencies.

Repair Time: 24 hours;

- b) replace all HID lamps once every 48 months; and,
- c) replace all non-LED lamps (except HID) once every 12 months.

ELECTRICAL MAINTENANCE SPECIFICATION E-540
HIGHWAY OPEN / CLOSED SIGN MAINTENANCE

1. OBJECTIVE

Highway open / closed signs are to operate and function without Deficiencies.

2. DETAILED PERFORMANCE SPECIFICATIONS

2.1 Routine Maintenance Services

In addition to Electrical Maintenance Specification E-001, the Contractor must:

- a) repair or replace highway open / closed signs and their components with Deficiencies.

Repair Time: 24 hours;

- b) replace all HID lamps once every 48 months;

- c) perform the following pixel test on all highway open / closed signs once every twelve months:

- (i) observe the sign with the 'OPEN' message active. If 2 or more pixels from any one character have failed, replace the module for that character; and,
- (ii) observe the sign with the 'CLOSED' message active. If 1 or more pixels from any one character have failed, replace the module for that character.

ELECTRICAL MAINTENANCE SPECIFICATION E-550
LED CHEVRON SIGN MAINTENANCE

1. OBJECTIVE

LED chevron signs are to operate and function without Deficiencies.

2. DETAILED PERFORMANCE SPECIFICATIONS

2.1 Routine Maintenance Services

In addition to Electrical Maintenance Specification E-001, the Contractor must:

- a) repair or replace LED chevron signs and/or their components with Deficiencies.
Repair Time: 7 days; and,
- b) repair or replace LED chevron signs as required if 30% or more of the LED's on a sign are not illuminating;

ELECTRICAL MAINTENANCE SPECIFICATION E-560
SPEED FEEDBACK SIGN MAINTENANCE

1. OBJECTIVE

Speed feedback signs are to operate and function without Deficiencies.

2. DETAILED PERFORMANCE SPECIFICATIONS

2.1 Routine Maintenance Services

In addition to Electrical Maintenance Specification E-001, the Contractor must:

- a) repair or replace speed feedback signs and/or their components with Deficiencies.
Repair Time: 7 days;
- b) clear logs and/or memory from all speed feedback signs once every twelve months; and,
- c) download data when requested by the Ministry, up to a maximum of twice per site each Contract Year.

ELECTRICAL MAINTENANCE SPECIFICATION E-570
LED W-064 WATCH FOR WILD ANIMALS SIGN

1. OBJECTIVE

LED W-064 watch for wild animals signs are to operate and function without Deficiencies.

2. DETAILED PERFORMANCE SPECIFICATIONS

2.1 Routine Maintenance Services

In addition to Electrical Maintenance Specification E-001, the Contractor must:

- a) repair or replace LED W-064 watch for wild animals signs and their components with Deficiencies.

Repair Time: 7 days; and,

- b) repair or replace LED W-064 watch for wild animals signs as required if 50% or more of the LED's on a sign are not illuminating.

**ELECTRICAL MAINTENANCE SPECIFICATION E-610
OVER-HEIGHT DETECTION SYSTEM MAINTENANCE**

1. OBJECTIVE

Over-height detection systems are to operate and function without Deficiencies.

2. DETAILED PERFORMANCE SPECIFICATIONS

2.1 Routine Maintenance Services

In addition to Electrical Maintenance Specification E-001, the Contractor must:

- a) repair or replace over-height detection systems and their components with Deficiencies.
Repair Time: 24 hours;
- b) clean transmitter and receiver lens glass on all over-height detection systems as required, and at least once every 6 months; and,
- c) test all over-height detection systems once every 12 months to ensure they function as per their Design;

ELECTRICAL MAINTENANCE SPECIFICATION E-640
ELECTRIC VEHICLE CHARGING STATION MAINTENANCE

1. OBJECTIVE

Electric Vehicle Charging Stations are to operate and function without Deficiencies.

1.1 Excluded Infrastructure

The following is not included in this specification:

- a) Networking equipment;
- b) Communications equipment;
- c) Updating of software or firmware.

2. DETAILED PERFORMANCE SPECIFICATIONS

2.1 Routine Maintenance Services

In addition to Electrical Maintenance Specification E-001, the Contractor must:

- a) repair or replace Electric Vehicle Charging Stations and their components with Deficiencies.

Repair Time: 24 hours;

- b) perform Preventative Maintenance on all Electric Vehicle Charging Stations, once during the month of April and once during the month of October, including testing the vehicle charge-cable retraction mechanism to confirm the charge-cable extends and retracts as originally designed by the manufacturer and repair or replace as required; and,
- c) input to Plugshare www.plugshare.com, and other equivalent as directed by the Ministry, a summary of any condition or disruption affecting use of an Electric Vehicle Charging Station by the public, and update Plugshare, and other equivalent, when the condition or disruption has been corrected.

ELECTRICAL MAINTENANCE SPECIFICATION E-910
ELECTRICAL INFRASTRUCTURE INCIDENT AND VANDALISM RESPONSE

1. OBJECTIVE

To prevent, remedy and protect highway users from Risks to Public Safety and Traffic Disruptions.

2. DETAILED PERFORMANCE SPECIFICATIONS

2.1 Routine Maintenance Services

The Contractor must:

- a) immediately install a fully actuated temporary traffic signal controller to re-establish traffic signal operations where traffic signal operation has been affected by incidents and/or vandalism. Note: The temporary traffic signal controller must be capable of providing rail pre-emption;
- b) immediately notify all agencies affected by the restricted functionality of the temporary traffic signal controller when the signal becomes operational;
- c) repair Damage to Government Property in accordance with the appropriate electrical maintenance specification;
- d) deliver to the Ministry photographs, documentation, and records for incidents at signalized intersections, including but not limited to:
 - (i) a copy of the signal timing sheet in effect at the time and date of the incident;
 - (ii) a copy of the traffic signal record form indicating when the signal timing sheet was implemented;
 - (iii) a copy of the controller programming that was in effect at the time and date of the incident;
 - (iv) a summary of all complaints and maintenance activities 7 days before to 7 days after the date of the incident;
 - (v) the last date the conflict monitor in the traffic signal controller cabinet was installed and tested;
 - (vi) any other information relevant to the incident.within 7 days of being requested by the Ministry;
- e) deliver to the Ministry photographs, documentation and records for all incidents, except those at signalized intersections, within 7 days of being requested by the Ministry;
- f) initiate a Damage to Government Property Claim within 7 days of the detection or notification of Damage to Government Property; and,
- g) deliver to the Ministry the completed Damage to Government Property Claim with the supporting documentation, including photographs, within 7 days of completing repairs.

ELECTRICAL MAINTENANCE SPECIFICATION E-920
TRAFFIC CONTROLLER AND CONTROLLER EQUIPMENT DISPOSAL

1. OBJECTIVE

Traffic controller and other electronic controller equipment removed from the field is accounted for, stored, and disposed of in a manner approved by the Ministry.

2. DETAILED PERFORMANCE SPECIFICATIONS

2.1 Routine Maintenance Services

The Contractor must:

- a) disable any controller whose cabinet has been subjected to impact or any other mechanical stress, and:
 - (i) remove the cabinet and internal components from the site;
 - (ii) label the equipment to identify that it has sustained damage and is not to be re-deployed;
- b) notify the Ministry Claims and Litigation department immediately if a controller cabinet has been damaged and/or removed;
- c) document and photograph all traffic controller equipment damaged by a motor vehicle accident;
- d) store the cabinet and internal components in a secure location sheltered from environmental exposure and make it available for examination by ICBC for 2 years, unless otherwise directed by the Ministry Representative;
- e) notify the Ministry Representative when the 2-year storage period has elapsed to:
 - (i) extend the storage period; or,
 - (ii) dispose of the equipment in an environmentally friendly manner approved by the Ministry; and,
- f) provide accurate electrical equipment disposal reports to the Ministry Representative within 30 days of disposal.

ELECTRICAL MAINTENANCE SPECIFICATION E-930
ELECTRICAL PATROL

1. OBJECTIVE

To identify electrical infrastructure that constitutes a Risk to Public Safety or a risk to the safety of operational personnel, and to identify any equipment with Deficiencies.

2. DETAILED PERFORMANCE SPECIFICATIONS

2.1 Routine Maintenance Services

In addition to Electrical Maintenance Specification E-001, the Contractor must:

- a) complete Patrols of all Inventory once every 2 months;
- b) take immediate and appropriate action during Patrols to protect highway users from Risks to Public Safety;
- c) take immediate and appropriate action during Patrols to ensure that Inventory operates without Deficiencies; and,
- d) report to the Ministry Representative immediately upon detection or notification of any conditions which affect the Highway in performing its function, but which are not specifically identified in these maintenance Specifications.

2.2 Materials

Not applicable to this maintenance Specification.

SCHEDULE 2

LOCAL AREA SPECIFICATIONS

1. Introduction

- 1.1. All capitalized words and phrases in this Schedule 2 will have the same meaning as those capitalized words and phrases in Article 1 of the Agreement and in Article 1 of Schedule 1 ("Specification"), as applicable.
- 1.2. All dollar amounts expressed in this Schedule 2 exclude all applicable taxes, duties and other charges.
- 1.3. The following Local Area Specifications provide additional maintenance and repair specifications for the outlined structures and locations. If multiple maintenance obligations or repair times apply to a particular item of inventory, the highest standard must be performed.
- 1.4. Each Local Area Specification applies to all Inventory described in the specification and located within the geographical area shown on its accompanying plan. Inventory included in a Local Area Specification may change due to future installations or connections to the applicable structures and systems.

LIST OF LOCAL AREA SPECIFICATIONS

Local Area Specification 1	Advanced Traveller Information System Maintenance – Lower Mainland East
Local Area Specification 2	Rail Crossing Advanced Traveller Information System
Local Area Specification 3	Fraser Valley Variable Speed Limit System Maintenance

LOCAL AREA SPECIFICATION 1

ADVANCED TRAVELLER INFORMATION SYSTEM MAINTENANCE – LOWER MAINLAND EAST

1. OBJECTIVE

To ensure the Advanced Traveller Information System (ATIS) is operational and functions without Deficiencies.

Included Infrastructure:

All electrical, electronic and camera equipment connected to the Advanced Traveller Information Systems at the locations outlined as follows on Appendix 1:

- PMH1 ATIS
- Fraser Crossing ATIS
- US Border ATIS

2. DETAILED PERFORMANCE SPECIFICATIONS

2.1. Routine Maintenance Services

In addition to Electrical Maintenance Specification E-001, the Contractor must:

- a) repair or replace all ATIS electrical components with Deficiencies, including but not limited to the following systems:
 - i) camera and video systems (including network devices, associated fibre optic cable and supporting communication components);

Repair Time: 48 hours
 - ii) power distribution systems (from the point of attachment to the power authority);

Repair Time: 48 hours
 - iii) advanced traffic controller systems (including network devices, associated fibre optic cable and supporting communication components);

Repair Time: 48 hours

- iv) vehicle detection systems (including radar, Bluetooth and loop sensors; network devices, associated fibre optic cable and supporting communication components); and,

Repair Time: 48 hours

- v) fibre optic equipment up to and including termination, patch panel and connection within the associated cabinet;

Repair Time: 48 hours

- b) maintain uninterruptible power supplies (UPS) in accordance with Electrical Maintenance Specification E-430;
- c) maintain dynamic message signs (DMS) in accordance with Electrical Maintenance Specification E-510;
- d) monitor the ATIS maintenance website daily and respond as required;
- e) up to 2 times a year, coordinate and schedule with the Ministry Representative to provide field support for firmware or software system updates; and,
- f) immediately advise the Transportation Management Centre (TMCBC) and the Ministry Representative if any of the electrical components are not functioning in accordance with their Design, Ministry Standards or manufacturer's specifications.

Note: If it is estimated by the Contractor and confirmed by the Ministry Representative that the cost to repair or replace systems or associated components, including labour, equipment and materials in response to a single incident exceeds \$10,000, the Ministry will reimburse the Contractor for the portion of the cost exceeding \$10,000. The Contractor is responsible for the cost up to \$10,000.

2.2. Materials

- a) Refer to Article 3 of the Introduction to the Specifications.

APPENDIX 1 – ADVANCED TRAVELLER INFORMATION SYSTEM (LOWER MAINLAND EAST) INCLUDED INFRASTRUCTURE

Earthstar Geographics

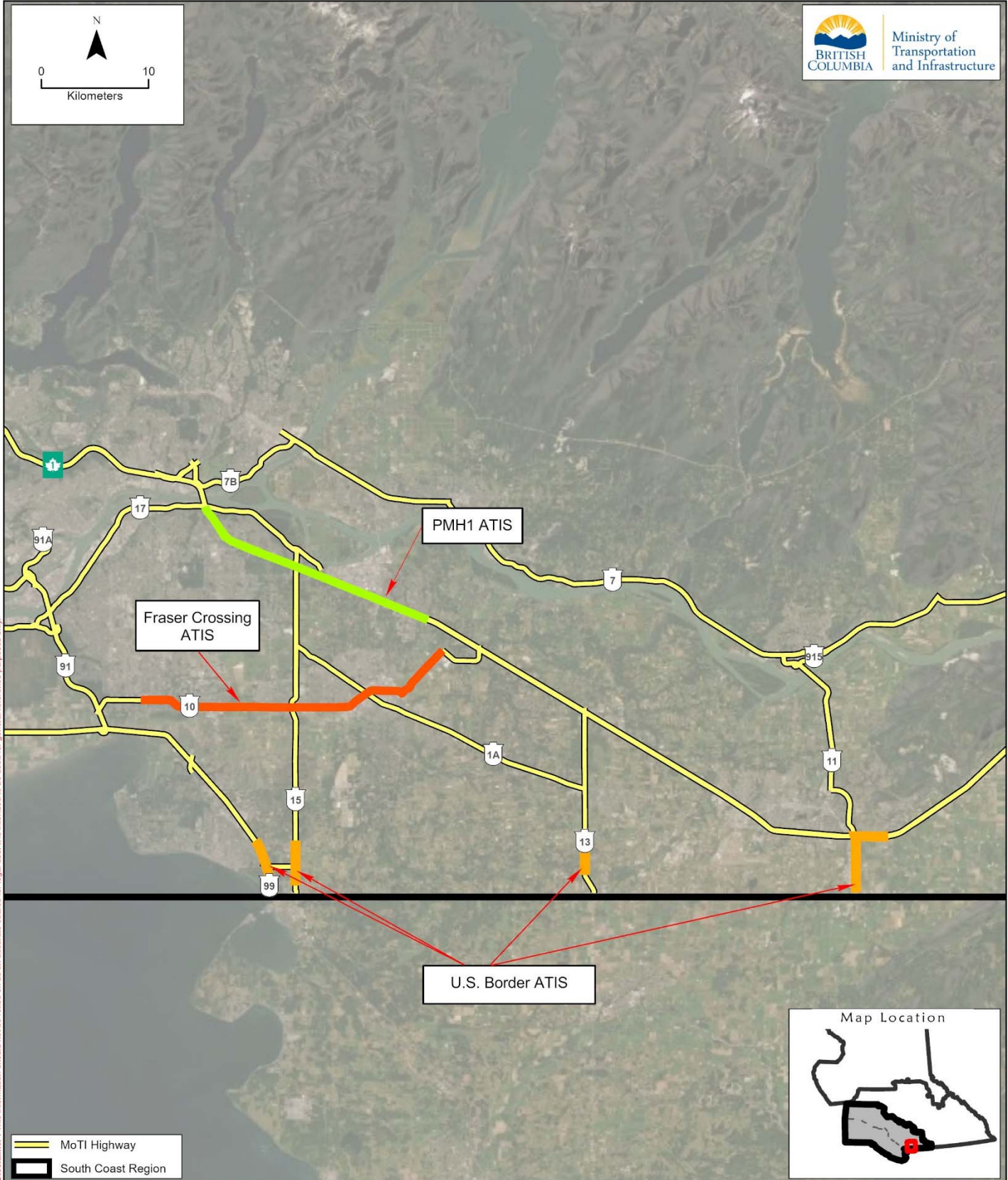

LOCAL AREA SPECIFICATION 2

RAIL CROSSING ADVANCED TRAVELLER INFORMATION SYSTEM MAINTENANCE

1. OBJECTIVE

To ensure the Rail Crossing Advanced Traveller Information System (RC-ATIS) is operational and functions without Deficiencies.

Included Infrastructure:

All electrical, electronic and camera equipment connected to the RC-ATIS at the locations outlined on Appendix 1.

2. DETAILED PERFORMANCE SPECIFICATIONS

2.1 Routine Maintenance Services

In addition to Electrical Maintenance Specification E-001, the Contractor must:

- a) repair or replace all RC-ATIS electrical components with Deficiencies, including but not limited to the following systems:
 - i) camera and video systems (including network devices and supporting communication components);

Repair Time: 48 hours
 - ii) power distribution systems (from the point of attachment to the power authority);

Repair Time: 48 hours
 - iii) rail crossing advanced traffic controller systems and associated components;

Repair Time: 48 hours
 - iv) train detector sensors and system (including network devices and supporting communication components); and,

Repair Time: 48 hours

- v) rail pre-emption system (including network devices and supporting communication components);

Repair Time: 48 hours

- b) maintain uninterruptible power supplies (UPS) in accordance with Electrical Maintenance Specification E-430;
- c) maintain dynamic message signs (DMS) in accordance with Electrical Maintenance Specification E-510;
- d) up to 3 times a year, coordinate and schedule with the Ministry Representative to provide field support for firmware or software system updates; and,
- e) immediately advise the railway authority, the Transportation Management Centre (TMCBC) and the Ministry Representative if any of the electrical components are not functioning in accordance with their Design, Ministry Standards or manufacturer's specifications.

Note: If it is estimated by the Contractor and confirmed by the Ministry Representative that the cost to repair or replace systems or associated components, including labour, equipment and materials in response to a single incident exceeds \$10,000, the Ministry will reimburse the Contractor for the portion of the cost exceeding \$10,000. The Contractor is responsible for the cost up to \$10,000.

2.2 Materials

- a) Refer to Article 3 of the Introduction to the Specifications.

APPENDIX 1 – RAIL CROSSING ADVANCED TRAVELLER INFORMATION SYSTEM – INCLUDED INFRASTRUCTURE

Township of Langley, USDA FSA, GeoEye, Maxar

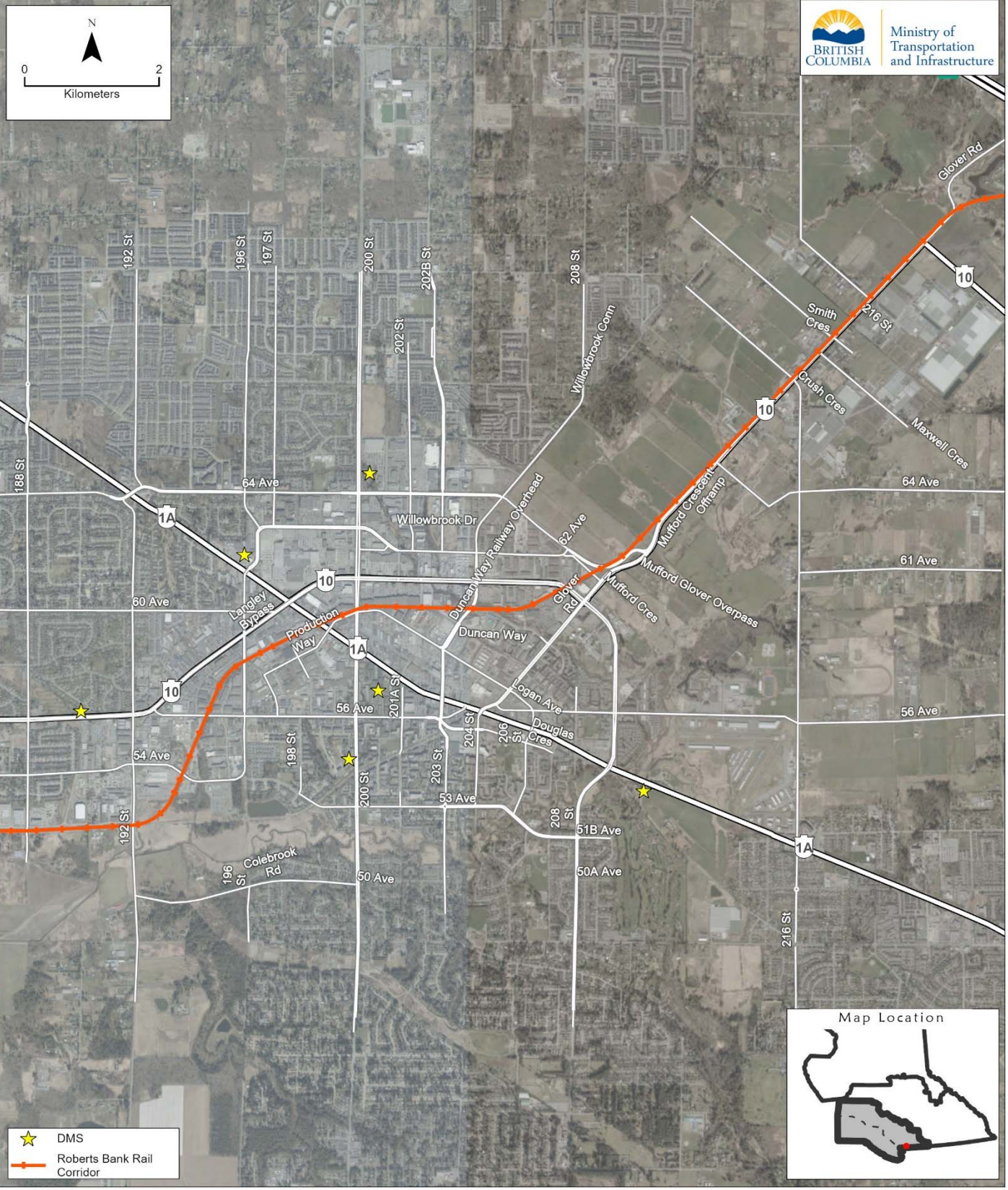

Disclaimer: This information should not be relied on as an accurate source for legal use. It is intended to be used for general reference purposes only.

- DMS
- Roberts Bank Rail Corridor



LOCAL AREA SPECIFICATION 3

FRASER VALLEY VARIABLE SPEED LIMIT SYSTEM MAINTENANCE

1. OBJECTIVE

To ensure the Fraser Valley Variable Speed Limit Systems (FV-VSLS) are operational and function without Deficiencies.

Included Infrastructure:

All electrical, electronic, and camera equipment connected to the structures outlined as follows on Appendix 1:

- Highway 1 VSLS (between Highway 11 and Prest Road, Chilliwack)
- Highway 3 VSLS (between Hope and Highway 3 and Highway 5 interchange)

2. DETAILED PERFORMANCE SPECIFICATIONS

2.1 Routine Maintenance Services

In addition to Electrical Maintenance Specifications E-001, the Contractor must:

- a) repair or replace all FV-VSLS electrical components with Deficiencies, including but not limited to the following systems:
 - i) camera and video systems (including network devices and associated fibre optic cable and supporting communication components);

Repair Time: 48 hours
 - ii) FV-VSLS sensors (including Radar Vehicle Sensing Device, Pavement Sensors, Present Weather Detectors and support structures and communication components);

Repair Time: 48 hours
 - iii) electronic signs (including Dynamic Message Signs, Variable Speed Limit Signs and the associated communication components and support structures);

Repair Time: 48 hours

- iv) power distribution systems (from the point of attachment to the power authority); and,

Repair Time: 48 hours

- v) fibre optic equipment up to and including termination, patch panel and connection within the associated cabinet;

Repair Time: 48 hours

- b) maintain uninterruptible power supplies (UPS) in accordance with Electrical Maintenance Specification E-430;
- c) maintain dynamic message signs (DMS) in accordance with Electrical Maintenance Specification E-510;
- d) perform Preventative Maintenance on all FV-VSLS electrical components once every 6 months;
- e) up to 2 times a year, coordinate and schedule with the Ministry Representative to provide field support for firmware or software system updates;
- f) perform calibration on the FV-VSLS sensors once every 6 months; and,
- g) immediately advise the Transportation Management Centre (TMCBC) and the Ministry Representative if any of the electrical components are not functioning in accordance with their Design, Ministry Standards or manufacturer's specifications.

Note: If it is estimated by the Contractor and confirmed by the Ministry Representative that the cost to repair or replace systems or associated components, including labour, equipment and materials in response to a single incident exceeds \$10,000, the Ministry will reimburse the Contractor for the portion of the cost exceeding \$10,000. The Contractor is responsible for the cost up to \$10,000.

2.2 Materials

- a) Refer to Article 3 of the Introduction to the Specifications.

APPENDIX 1 – FRASER VALLEY VARIABLE SPEED LIMIT SYSTEM - INCLUDED INFRASTRUCTURE

Earthstar Geographics, Esri, HERE, Garmin, FAO, NOAA, USGS, EPA, NPS, NRCAN, Parks Canada

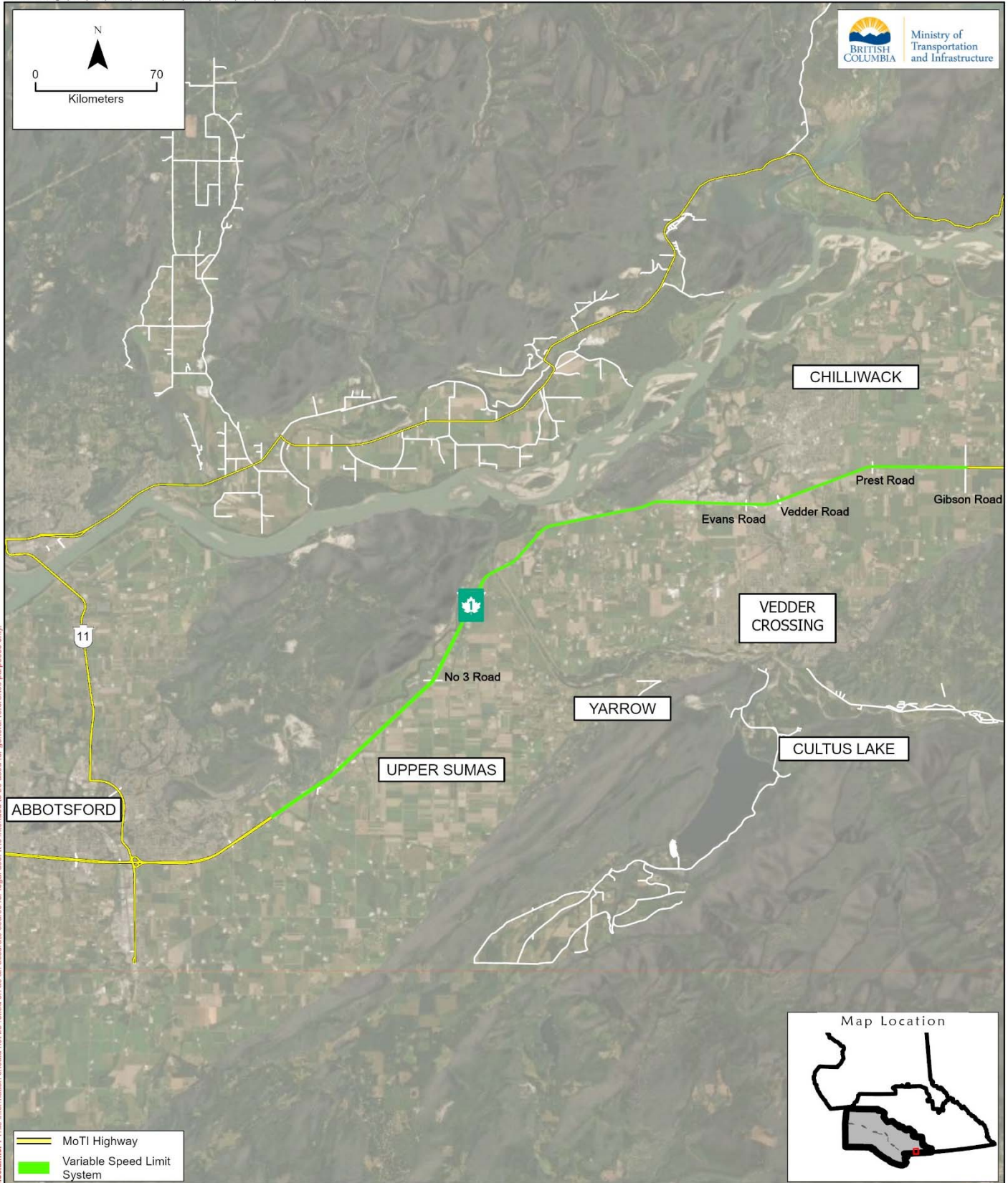

APPENDIX 1 – FRASER VALLEY VARIABLE SPEED LIMIT SYSTEM - INCLUDED INFRASTRUCTURE

Earthstar Geographics, Esri, HERE, Garmin, FAO, NOAA, USGS, EPA, NPS, NRCAN, Parks Canada

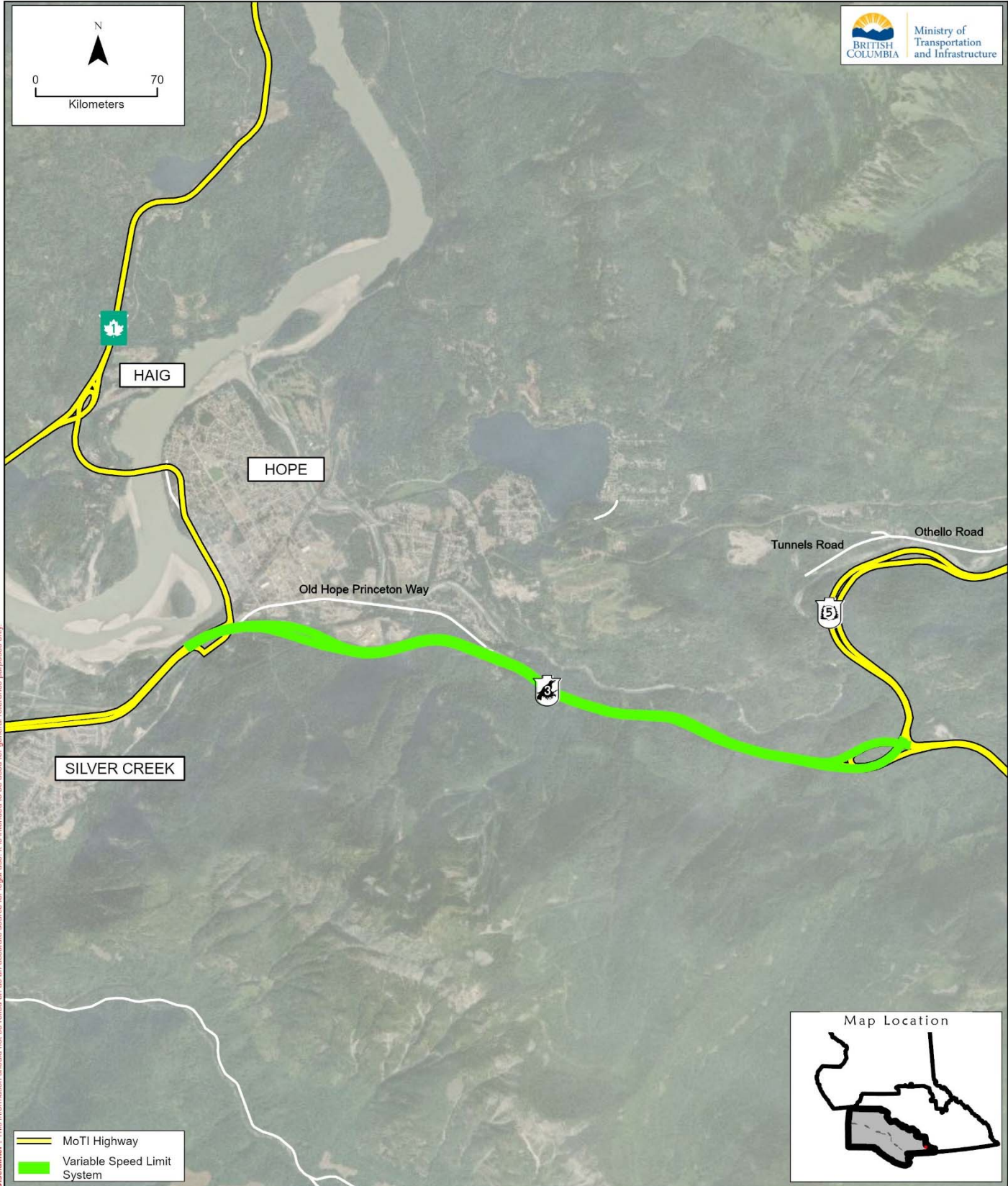

Disclaimer: This information should not be relied on as an accurate source for legal use. It is intended to be used for general reference purposes only.

SCHEDULE 3 – ELECTRICAL SERVICE AREA

(MAP REFERENCE)

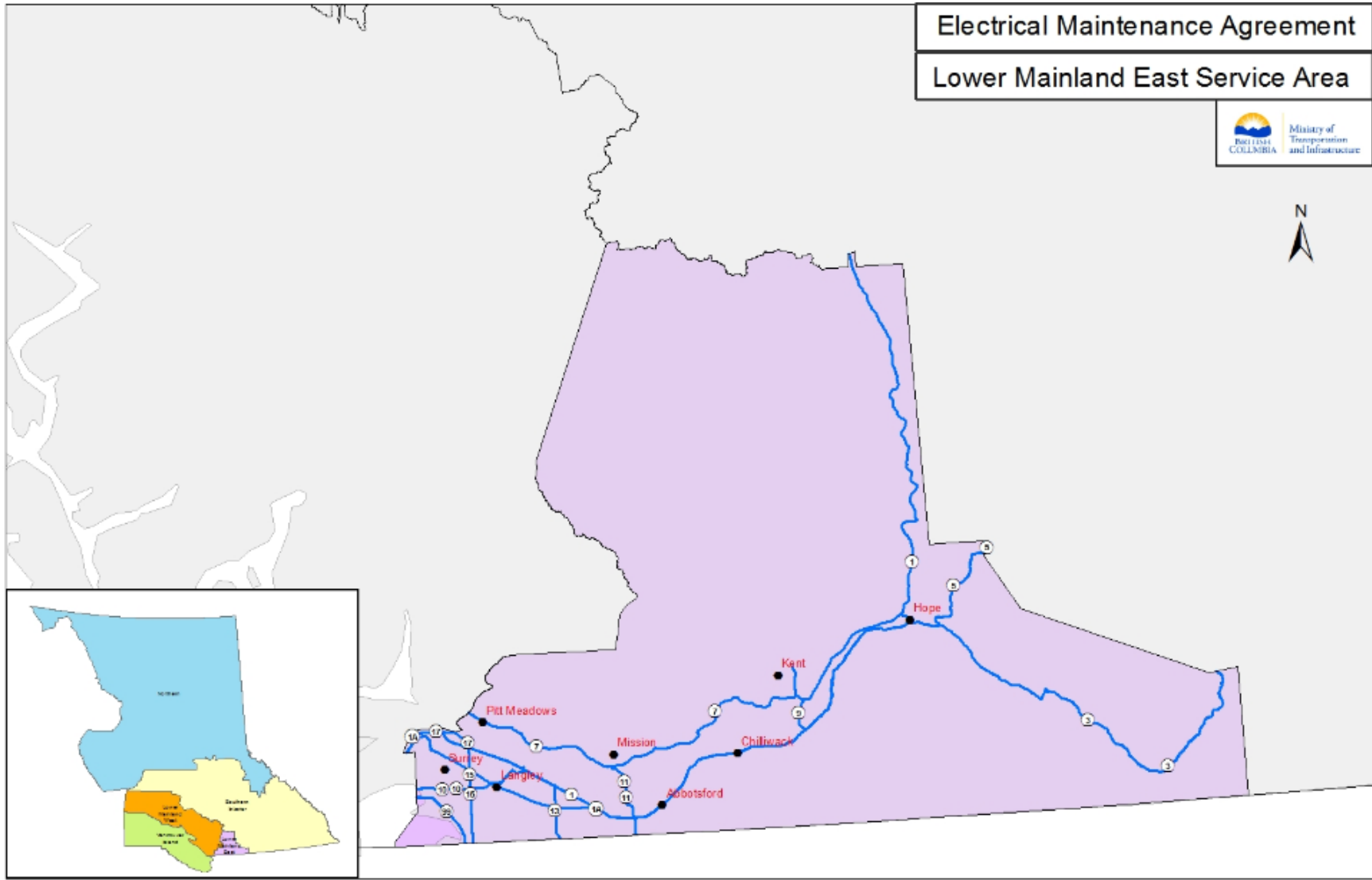

APPENDIX 1 (TO SCHEDULE 3)

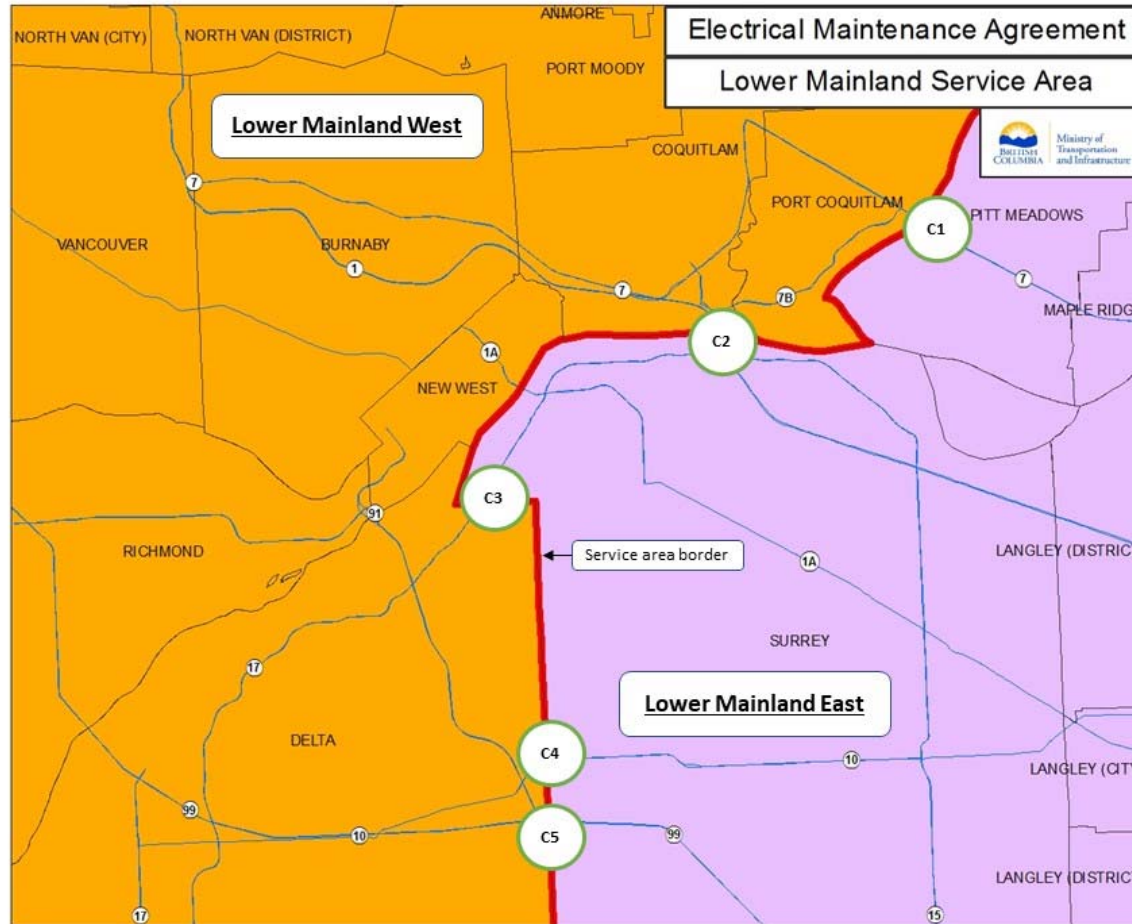

Crossing Number	Crossing Description
C1	Pitt River Bridge Hwy 7 Transition
C2	Port Mann Bridge Hwy 1 Transition
C3	Hwy 17 Crossing and 120th St Transition
C4	Hwy 10 and 120th St Transition
C5	Hwy 99 and Hwy 91 Transition



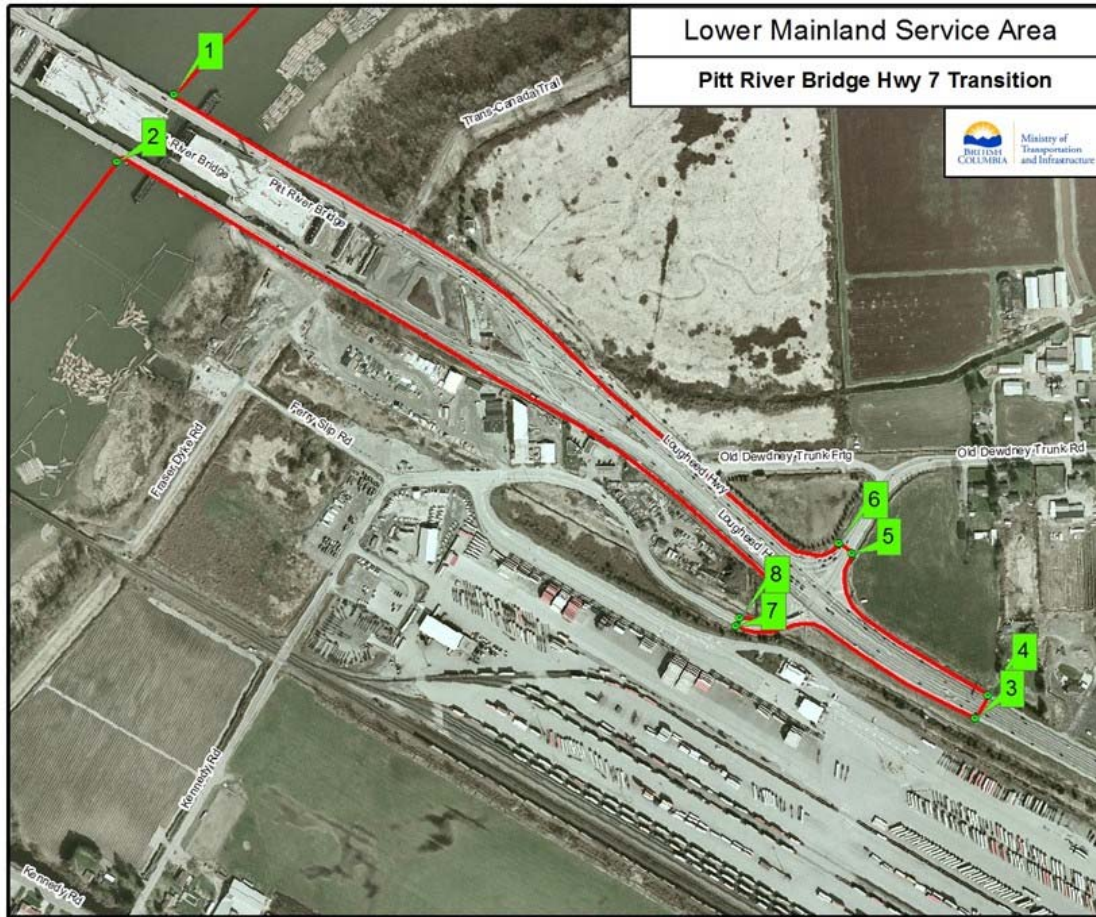

Lower Mainland Service Area
Pitt River Bridge Hwy 7 Transition

No.	Longitude	Latitude
1	122° 43' 44.81" W	49° 14' 54.28" N
2	122° 43' 48.16" W	49° 14' 51.89" N
3	122° 43' 1.60" W	49° 14' 30.07" N
4	122° 43' 0.83" W	49° 14' 30.90" N
5	122° 43' 8.06" W	49° 14' 36.32" N
6	122° 43' 8.77" W	49° 14' 36.71" N
7	122° 43' 14.72" W	49° 14' 33.84" N
8	122° 43' 14.49" W	49° 14' 34.15" N

 Electrical Boundary



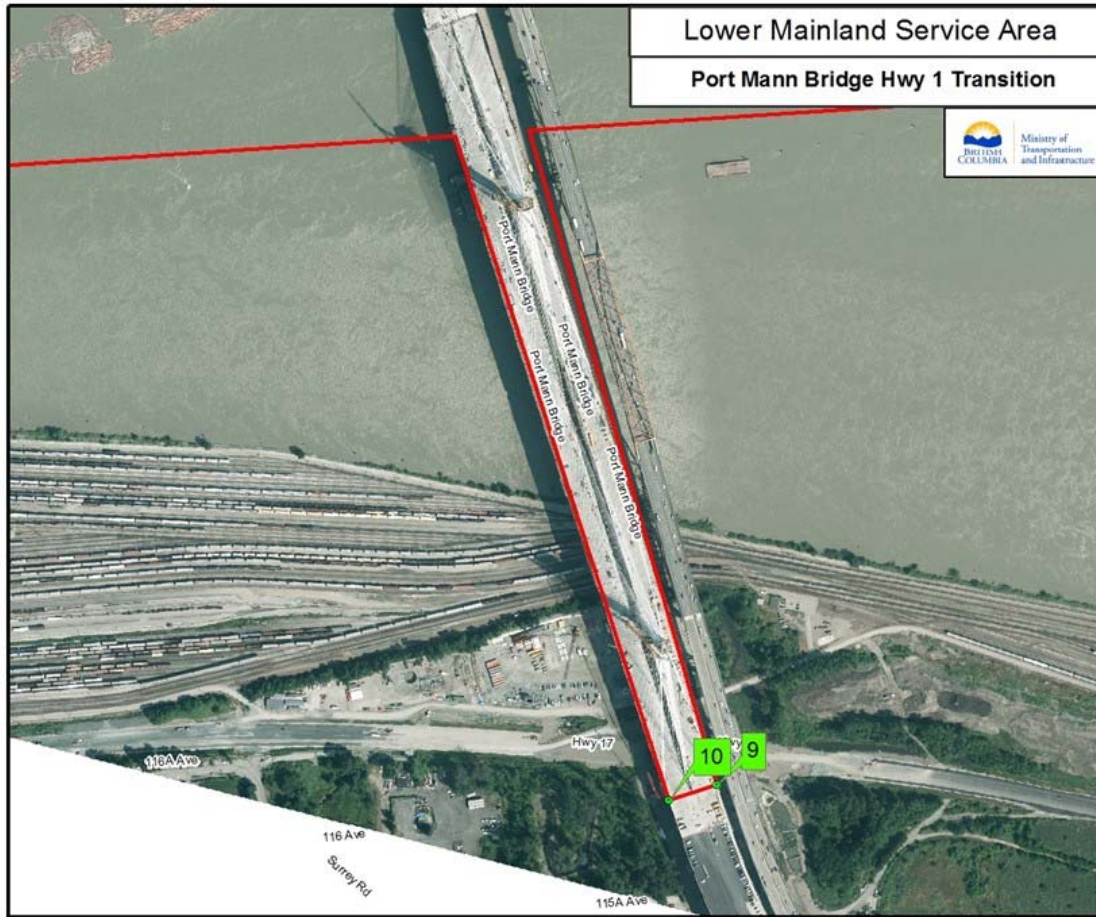

Lower Mainland Service Area

Port Mann Bridge Hwy 1 Transition



No.	Longitude	Latitude
9	122° 48' 37.02" W	49° 12' 50.14" N
10	122° 48' 39.58" W	49° 12' 49.67" N

 Electrical Boundary





No.	Longitude	Latitude
11	122° 54' 47.99" W	49° 10' 37.64" N
12	122° 54' 49.00" W	49° 10' 37.65" N

 Electrical Boundary





Lower Mainland Service Area

Hwy 10 and 120th St Transition



No.	Longitude	Latitude
13	122° 53' 18.57" W	49° 6' 30.08" N
14	122° 53' 18.55" W	49° 6' 29.31" N

 Electrical Boundary





Lower Mainland Service Area

Hwy 99 and Hwy 91 Transition



No.	Longitude	Latitude
15	122° 53' 19.11" W	49° 5' 31.33" N
16	122° 53' 19.22" W	49° 5' 30.38" N

 Electrical Boundary



SCHEDULE 4 – INVENTORY

Lower Mainland East Service Area

Spec #	Inventory Type	Inventory as of the Commencement Date
E-110	Fully Actuated Traffic Signal	128
E-110	Pedestrian Actuated Signal	4
E-110	Pedestrian Actuated Flasher (special x-walks / solar powered) / fire signal	9
E-120	Overhead Flashing Beacon	8
E-210	Post Mounted Flasher	42
E-220	Overhead Warning Sign with Flashers	143
E-230	Solar Powered Flasher	0
E-230	Solar Powered Overhead Warning Sign with Flashers	0
E-310	Street, Roadway, Area and Sign Lighting (Luminaires)	5564
E-420	Permanent Traffic Count Station / ATIS Cabinet	19
E-430	Uninterruptible Power Supply (UPS)	145
E-440	Web Camera	46
E-440	Remote Web Camera (greater than 250km one way from Base Location)	0
E-450	Solar Powered Web Camera	0
E-450	Remote Solar Powered Web Camera (greater than 250km one way from Base Location)	0
E-460	Bluetooth Reader	0
E-480	Rest Area Wi-Fi Power	0
E-490	Solar Powered Units	0
E-510	LED and Flip Disk Dynamic Message Sign (also referred to as Changeable Message Sign CMS)	17
E-540	Highway Open / Closed	11
E-550	LED Chevron Signs	19
E-560	Speed Feedback Signs	2
E-570	LED W-064 Watch for Wild Animal Signs	0
E-610	Overheight Detection System	0
E-640	Electric Vehicle Charging Station	0
E-640	Remote Electric Vehicle Charging Station (greater than 250km one way from Base Location)	0
LAS	69 KV Transformer Station	0

NOTE: The Detailed Inventory will be electronically provided to the Contractor by the Province in Excel.

SCHEDULE 5 – FEE

PART 1 ROUTINE MAINTENANCE SERVICES - ANNUAL PRICE

1. For its provision of Routine Maintenance Services, subject to Part 3 below and the terms of this Agreement, the Province will pay the Contractor in 12 equal installments without the need for the Contractor to invoice the Province. The Province will add the GST to these installment payments for the Contractor to remit GST to the taxing authority. In the First Contract Year, the Province will pay the Contractor the Base Annual Price, and in subsequent Contract Years the Province will pay the Contractor the Adjusted Annual Price. Payment will be made in accordance with Appendix 1 of this Schedule on the Working Day immediately following the last day of each Contract Month. For clarity, in the event the Payment Due Date column in Appendix 1 specifies a date that is not a Working Day, payment will be made no later than the next Working Day in accordance with this Article. Appendix 1 of this Schedule will be updated from time to time by the Province.

Unless this Agreement is renewed pursuant to Section 3.4, the installment applicable to the last Contract Month during the Term will be paid 10 Working Days after the end of the Term. If this Agreement is renewed pursuant to Section 3.4, the installment applicable to the last Contract Month during the renewal term will be paid 10 Working Days after the end of the renewal term. This Article will survive the expiry or earlier termination of this Agreement.

2. The Annual Price applicable to a Contract Year is the maximum amount payable by the Province to the Contractor for provision of Routine Maintenance Services during that Contract Year, and each monthly payment described in Part 1 of this Schedule:
 - (a) constitutes the maximum amount payable to the Contractor for performing, during each Contract Month, the Routine Maintenance Services and all other obligations of the Contractor under this Agreement, except Additional Services; and
 - (b) comprises equal installment payments for the Routine Maintenance Services, and all other obligations to be performed by the Contractor, except Additional Services, during the applicable Contract Year;

and the Contractor will not be entitled to any additional compensation, notwithstanding the level of Routine Maintenance Services performed by the Contractor during the Contract Month corresponding to the applicable monthly payment.

PART 2 ADDITIONAL SERVICES

3. For the provision of Additional Services the Contractor will invoice the Province in accordance with Schedule 8 ("Additional Services"). The Province will pay the Contractor in accordance with Schedule 8 ("Additional Services") subject to the Province confirming the adequacy of the performance of such Additional Services and subject to Part 3 below and any other provisions of this Agreement for each Work Order no later than 30 days following receipt of said invoice.

PART 3 FINAL PAYMENT HOLDBACK

4. The Province may retain a holdback from the final payment due under either Part 1 or Part 2 of this Schedule up to the full amount of the final payment due if, as of the due date of that payment, the Ministry Representative is not satisfied that the Services required to be performed by the Contractor has been completed. The Province may apply all or part of the amount retained towards the cost to

the Province for completing any Services which the Contractor failed to perform during the Term, prior to paying any remaining balance, if any, of that amount to the Contractor.

5. No interest will be payable by the Province to the Contractor on any amount retained as a holdback in accordance with this Schedule.

APPENDIX 1 (TO SCHEDULE 5) – PAYMENT SCHEDULE

Lower Mainland East Electrical Service Area

First Contract Year

Payment Due Date	Payment Period	Payment Amount
September 30, 2021	September 1, 2021 to September 30, 2021	\$@@
October 31, 2021	October 1, 2021 to October 31, 2021	\$@@
November 30, 2021	November 1, 2021 to November 30, 2021	\$@@
December 31, 2021	December 1, 2021 to December 31, 2021	\$@@
January 31, 2022	January 1, 2022 to January 31, 2022	\$@@
February 28, 2022	February 1, 2022 to February 28, 2022	\$@@
March 31, 2022	March 1, 2022 to March 31, 2022	\$@@
April 30, 2022	April 1, 2022 to April 30, 2022	\$@@
May 31, 2022	May 1, 2022 to May 31, 2022	\$@@
June 30, 2022	June 1, 2022 to June 30, 2022	\$@@
July 31, 2022	July 1, 2022 to July 31, 2022	\$@@
August 31, 2022	August 1, 2022 to August 31, 2022	\$@@

Contract Year payment amounts = $\frac{\text{Annual Price}}{12}$

Note: As per Section 1 Part 1 of this Schedule the installment applicable to the last contract month during the Term will be paid 10 Working Days after the end of the Term.

SCHEDULE 6 – COST FOR CHANGES TO INVENTORY

1. The cumulative net change in the Daily Cost or Revised Daily Cost, as the case may be, as a result of a notice under Section 8.1 of this Agreement will be determined by the following formula set out in Section 2 of this Schedule if the change results in addition or deletion of Inventory.
2. The formula for calculating the change in Daily Cost or Revised Daily Cost, as the case may be, resulting from an addition or deletion of Inventory is:

$$A/365 \times B$$

where the capital letters in this formula have the following meanings:

"A" equals the Annual Costs, as shown on Table 1; and

"B" equals the number of days remaining in the Contract Year as of the effective date of the addition or deletion;

3. The Revised Daily Cost determined from time to time in Section 8.5(b) of this Agreement will be the aggregate of:
 - (a) the Daily Cost, and
 - (b) the total net change in Daily Cost calculated pursuant to this Schedule,all as determined by the Province.

TABLE 1

Spec #	Inventory Type	Costs
E-110	Fully Actuated Signalized Intersection	\$ 3,600
E-110	Pedestrian Actuated Signal	\$ 1,440
E-110	Pedestrian Actuated Flasher (special x-walks / solar powered) / fire signal	\$ 575
E-120	Overhead Flashing Beacon	\$ 290
E-210	Post Mounted Flasher	\$ 75
E-220	Overhead Warning Sign with Flashers	\$ 290
E-230	Solar Powered Flasher	\$ 200
E-230	Solar Powered Overhead Warning Sign with Flashers	\$ 865
E-310	Street, Roadway, Area and Sign Lighting (Luminaires)	\$ 145
E-420	Permanent Traffic Count Station / ATIS cabinet	\$ 720
E-430	Uninterruptible Power Supply (UPS)	\$ 575
E-440	Web Camera	\$ 575
E-440	Remote Web Camera (greater than 250km one way from Base Location)	\$ 865
E-450	Solar Powered Web Camera	\$ 1,330
E-450	Remote Solar Powered Web Camera (greater than 250km one way from Base Location)	\$ 1,820
E-460	Bluetooth Reader	\$ 150
E-480	Rest Area Wi-Fi Power	\$ 180
E-490	Solar Powered Units	\$ 630
E-510	LED and Flip Disk Dynamic Message Sign (also referred to as Changeable Message Sign CMS)	\$ 720
E-540	Highway Open / Closed	\$ 460
E-550	LED Chevron Sign	\$ 235

Spec #	Inventory Type	Costs
E-560	Speed Feedback Signs	\$ 370
E-570	LED W-064 Watch for Wild Animal Signs	\$ 235
E-610	Overheight Detection System	\$ 230
E-640	Electric Vehicle Charging Station	\$ 2,100
E-640	Remote Electric Vehicle Charging Station (greater than 250km one way from Base Location)	\$ 3,500
LAS	69 KV Transformer Station	\$ 3,450

SCHEDULE 7 – ANNUAL ADJUSTMENT PROCESS

Definitions

1. In this Schedule, unless the context otherwise requires:

- (a) **"Changes to Inventory Adjustment Factor"** means, in respect of a Contract Year;
- (i) an amount equivalent to the Daily Cost for the immediately preceding Contract Year which would have resulted (calculated in accordance with the provisions of Schedule 6 ("Cost for Changes to Inventory")) based on the assumptions that:
 - (A) any changes to the Inventory made by the Province during that immediately preceding Contract Year under Section 8.1 of this Agreement were made on the first day of that immediately preceding Contract Year;
 - (B) the 2% threshold set out in Sections 8.3 and 8.4 of this Agreement were not operative; and
 - (C) no adjustment in the Annual Price applicable to that immediately preceding Contract Year was made pursuant to Article 9 of this Agreement;

divided by:

- (ii) an amount equivalent to the Daily Cost for the immediately preceding Contract Year which would have resulted based on the assumptions that:
 - (A) there were no changes to the Inventory made by the Province during that immediately preceding Contract Year under Section 8.1 of this Agreement; and
 - (B) no adjustment in the Annual Price applicable to that immediately preceding Contract Year was made pursuant to Article 9 of this Agreement;
- (b) **"Insurance Premium Adjustment Value"** means 80% of any increase/decrease in the annual insurance premium costs as indicated in the completed Insurance Premium Adjustment Form delivered by the Contractor pursuant to Section 19.4(b) compared to the Insurance Premium Quote or the annual insurance premium amount verification delivered by the Contractor pursuant to Section 19.4(b) for the immediately preceding Contract Year, as the case may be, subject to the Province determining the following to its satisfaction:
- (i) that any such increase reflects a general increase in the annual premiums for such insurance based on the availability or otherwise of alternative quotes that may be obtained on a competitive basis for the renewal or replacement of such insurance with respect to the performance of its Services under the Agreement; and/or
 - (ii) that the initial amount of the Insurance Premium Quote(s) or any subsequent annual premium amounts delivered under Section 19.4(b) was not based solely or in part on an agreement or arrangement, written or otherwise, by any person to artificially adjust such amounts.

The Province will be entitled to request whatever documents or information it may deem fit, including but not limited to statutory declarations in a form determined by the Province, from the Contractor and insurer(s) involved, as part of the above determinations.

- (c) **"Insurance Premium Quote"** means \$@@ or the total premium quote submitted by the Contractor's insurer pursuant to the Insurance Premium Adjustment Form for each subsequent Contract Year;
- (d) **"Labour Component"** means the portion of Annual Price assumed to represent labour costs and will be measured using the annual average of the Fixed-weighted Index of Average Hourly Earnings for all employees (SEPH), excluding overtime, unadjusted for seasonal variation, for selected industries classified under the North American Industry Classification System (NAICS); British Columbia; Industrial Aggregate excluding unclassified businesses available from the Statistics Canada table No. 14-10-0213-01 in respect of a calendar year ("SEPH Table"), or, if not available, such other similar wage index selected by the Province. The Province will calculate the year over year percentage change for the Labour Component of the Price Adjustment Factor utilizing the annually released Statistics Canada SEPH Tables for each Contract Year;
- (e) **"Fuel Component"** means the portion of price assumed to represent fuel costs and will be measured using the Annual Average of Industry Price Indexes for Non-Metallic Mineral Products and Petroleum and Coal Products, by regions; British Columbia; Diesel Fuel available from Statistics Canada table No. 18-10-0031-01 in respect of a calendar year, or, if not available, such other similar index selected by the Province. The year over year percentage change for the Fuel Component of the Price Adjustment Factor will be calculated using the data from the preceding 2 years pursuant to the illustration in Appendix 3 utilizing this annually released Statistics Canada table within 10 Working Days of the date the Labour Component is drawn as outlined in Section 1(d) of this Schedule;
- (f) **"Residual Component"** means the portion of the Annual Price assumed to represent the remainder of the Contractor's variable costs in the agreement and will be measured using the Annual Average of the Consumer Price Index for British Columbia, British Columbia all-items basket made available by Statistics Canada in table No. 18-10-0004-01 in respect of a calendar year, or, if not available, of such other similar index selected by the Province. The year over year percentage change for the Residual Component of the Price Adjustment Factor will be calculated utilizing this annually released Statistics Canada table within 10 Working Days of the date the Labour Component is drawn as outlined in Section 1(d) of this Schedule;
- (g) **"Price Adjustment Factor"** means, in respect of a calendar year, the aggregate of:
- (i) 35% of:
 - (A) the Fixed-weighted Index of Average Hourly Earnings for the immediately preceding calendar year, minus;
 - (B) the Fixed-weighted Index of Average Hourly Earnings for the calendar year immediately preceding the calendar year described in clause (A) of this subparagraph (i);divided by the Fixed-weighted Index of Average Hourly Earnings for the calendar year immediately preceding the calendar year described in clause (A) of this Subsection (i); and
 - (ii) 10% of:

- (A) the Annual Average of Industry Price Indexes for Non-Metallic Mineral Products and Petroleum and Coal Products for the immediately preceding calendar year, minus;
- (B) the Annual Average of Industry Price Indexes for Non-Metallic Mineral Products and Petroleum and Coal Products for the calendar year immediately preceding the calendar year described in clause (A) of this subparagraph (iii);

divided by the Annual Average of Industry Price Indexes for Non-Metallic Mineral Products and Petroleum and Coal Products for the calendar year immediately preceding the calendar year described in clause (A) of this subparagraph (iii); and

(iii) 47% of:

- (A) the Annual Average of the Consumer Price Index for British Columbia for the immediately preceding calendar year, minus;
- (B) the Annual Average of the Consumer Price Index for British Columbia for the calendar year immediately preceding the calendar year described in clause (A) of this subparagraph (iv);

divided by the Annual Average of the Consumer Price Index for British Columbia for the calendar year immediately preceding the calendar year described in clause (A) of this subparagraph (iv).

Calculation of Price Adjustment Factor

2. Commencing with the 2021 calendar year, the Province will, by no later than the end of the month of April of each subsequent calendar year or as soon as reasonably practicable after receipt of the revised official statistics for table No. 14-10-0213-01 referenced in Section 1(d) of this Schedule:
 - (a) calculate the Price Adjustment Factor for the calendar year; and
 - (b) provide to the Contractor copies of the calculations.
3. Two sample Price Adjustment Factor calculations are set out in Appendix "2" attached to this Schedule.

Calculation of Other Adjustments

4. By no later than the beginning of each Contract Year of this Agreement, the Province will:
 - (a) calculate the Changes to Inventory Adjustment Factor for the Contract Year;
 - (b) calculate the Adjusted Annual Price for the Contract Year in accordance with the formula set out in Appendix "1" attached to this Schedule;
 - (c) calculate revised daily and yearly rates for the changes to Inventory for the Contract Year by adjusting the daily and yearly rates in the changes to Inventory in effect at the beginning of the immediately preceding Contract Year by the Price Adjustment Factor; and
 - (d) include where applicable the cost of adjustments made to Routine Maintenance Services pursuant to Article 9 of this Agreement during the Contract Year.

Provision of Calculations and Notice of Fees Adjustments

5. The Province will provide to the Contractor copies of the calculations described in Section 4 of this Schedule forthwith upon the completion of the calculations.

Calculation Disagreements

6. If the Contractor should disagree with any of the calculations the Contractor may:
 - (a) within 30 days of receipt of the calculations, notify the Province in writing of its disagreement, specifying the reasons therefore; and
 - (b) if the parties have not resolved a disagreement within 30 days of notification being given under Subsection 6(a) of this Schedule, the Province will refer the disagreement to Arbitration pursuant to Article 23 of this Agreement, which Arbitration will be conducted by an independent professional accountant.

Delivery of Revised Schedules and Tables

7. As soon as reasonably practicable after the calculations described in Section 4 of this Schedule become final and binding after 30 days pursuant to Section 6 of this Schedule or Article 23 of this Agreement, the Province will prepare and deliver to the Contractor revised:
 - (a) Schedule 4 ("Inventory"), Table A;
 - (b) Schedule 5 ("Fee"), Appendix 1 – Payment Schedule; and
 - (c) Schedule 6 ("Cost for Changes to Inventory").reflecting those calculations and adjusted fees as applicable.

Rounding

8. Rounding shall be as follows:
 - (a) The numbers used in any of the calculations made in accordance with this Schedule and the numbers resulting from the calculations made under Subsection 2(a) and 4(a) of this Schedule will be rounded, as necessary, to 5 decimal places; and
 - (b) The numbers resulting from the calculations made under Subsections 4(b), (c) and (d) of this Schedule will be rounded, as necessary, to 2 decimal places.

Changes in Bases of Indices

9. If any of the indices used as proxies for the Labour, Fuel or Residual Components for a calendar year is published with a different base from that of the previous calendar year, the Province may adjust the affected value of the index so that the value of the index for each calendar year has a common base prior to including the value of the index in the calculation of the Price Adjustment Factor.

APPENDIX 1 (TO SCHEDULE 7) – ADJUSTED ANNUAL PRICE FORMULA

1. The formula for calculating the Adjusted Annual Price for a Contract Year under Section 4 (b) of this Schedule is:

$$[(A - B) \times C \times D + B] + E \pm F^{(1)} \quad \underline{\text{OR}} \quad [(A - B \pm F^{(2)}) \times C \times D + B] + E$$

where the capital letters in this formula have the following meanings:

- "A" equals the Annual Price for the immediately preceding Contract Year prior to the making of any adjustments during that immediately preceding Contract Year pursuant to Articles 8 and/or 9 of this Agreement;
 - "B" equals the Insurance Premium Quote and/or the annual insurance premium amount verification delivered by the Contractor pursuant to Section 19.4(b) and applicable on the commencement of the immediately preceding Contract Year;
 - "C" equals the Changes to Inventory Adjustment Factor for the Contract Year;
 - "D" equals the Price Adjustment Factor for the last calendar year ending prior to the beginning of the Contract Year;
 - "E" equals the Insurance Premium Adjustment Value; and
 - "F" equals the cost of adjustments made to the Routine Maintenance Services pursuant to Article 9 of this Agreement during the Contract Year, if applicable.
2. Sample calculations of the Adjusted Annual Price for 2 Contract Years are set out in Appendix "3" attached to this Schedule.

Notes:

- 1 If an adjustment is made pursuant to Article 9 of this Agreement which is effective at the beginning of the Contract Year, the annual value of the change will be added at the end of the calculation of the Annual Price after all other calculations have been made; and
- 2 If during the Contract Year an adjustment is made pursuant to Article 9 of this Agreement, the Province will update the Schedule 5 ("Fee") Appendix 1 to reflect the prorated portion of the annual value of the adjustment to the end of the Contract Year and the full annual value of the change to Services will be included in the following Contract Year's annual adjustment before the Changes to Inventory Adjustment Factor and the Insurance Premium Adjustment Value are applied.

APPENDIX 2 (TO SCHEDULE 7) – SAMPLE PRICE ADJUSTMENT FACTOR CALCULATION

The Price Adjustment Factor is an annual adjustment for variable costs only. The Province estimates that the variable costs are 92% of the total costs. These variable costs are outside the direct control of the Contractor and specifically exclude fixed costs which take the form of overhead and profit.

FOR CONTRACT YEAR 2⁽¹⁾

Component	Average Annual Year 1	Average Annual Year 2	% Change	% Weighting	Inflation
Labour Component ⁽²⁾	119.99	122.93	2.45%	35%	0.858%
Fuel Component ⁽³⁾	257.50	169.63	-34.12%	10%	-3.412%
Residual Component ⁽⁴⁾	112.33	112.28	-0.04%	<u>47%</u>	<u>-0.021%</u>
Total Percentage				92%	-2.576%
Price Adjustment Factor (1-0.02576)					0.97424

(1) This sample calculation is for illustrative purposes only.

(2) Source: Statistics Canada, table No. 14-10-0213-01, Industrial Aggregate excluding unclassified businesses Fixed-weighted Index of Average Hourly Earnings for all employees (Survey of Employment, Payrolls and Hours or SEPH), excluding overtime, unadjusted for seasonal variation, for selected industries classified under the North American Industry Classification System (NAICS) in British Columbia.

(3) Source: Statistics Canada, table No. 18-10-0031-01, Annual Average of Industry Price Indexes for Non-Metallic Mineral Products and Petroleum and Coal Products, by regions; British Columbia.

(4) Source: Statistics Canada, table No. 18-10-0004-01, Annual Average of the Consumer Price Index for British Columbia (CPI), British Columbia all-items basket.

Please Note: Statistics Canada data is available free of charge and can be accessed using the following link: <http://www5.statcan.gc.ca/cansim/home-accueil?lang=eng>.

APPENDIX 2 (TO SCHEDULE 7) - CONTINUED
SAMPLE PRICE ADJUSTMENT FACTOR CALCULATION
FOR CONTRACT YEAR 3⁽¹⁾

Component	Average Annual Year 2	Average Annual Year 3	% Change	% Weighting	Inflation
Labour Component ⁽²⁾	122.52	124.38	1.52%	35%	0.531%
Fuel Component ⁽³⁾	169.88	190.61	12.20%	10%	1.220%
Residual Component ⁽⁴⁾	111.90	113.84	1.73%	<u>47%</u>	<u>0.815%</u>
Total Percentage				92%	2.566%
Price Adjustment Factor (1 + 0.02566)					1.02566

(1) This sample calculation is for illustrative purposes only.

(2) Source: Statistics Canada, table No. 14-10-0213-01, Industrial Aggregate excluding unclassified businesses Fixed-weighted Index of Average Hourly Earnings for all employees (Survey of Employment, Payrolls and Hours or SEPH), excluding overtime, unadjusted for seasonal variation, for selected industries classified under the North American Industry Classification System (NAICS) in British Columbia.

(3) Source: Statistics Canada, table No. 18-10-0031-01, Annual Average of Industry Price Indexes for Non-Metallic Mineral Products and Petroleum and Coal Products, Diesel, by regions; British Columbia.

(4) Source: Statistics Canada, table No. 18-10-0004-01, Annual Average of the Consumer Price Index for British Columbia (CPI), British Columbia all-items basket.

Please Note: Statistics Canada data is available free of charge and can be accessed using the following link: <http://www5.statcan.gc.ca/cansim/home-accueil?lang=eng>.

**APPENDIX 3 (TO SCHEDULE 7) – SAMPLE ADJUSTED ANNUAL PRICE CALCULATION
FOR CONTRACT YEAR 2**

<u>Description</u>	<u>Action</u>	<u>Amount</u>	<u>Ref.</u>
Base Annual Price		\$ 2,000,000.00	A
Insurance Premium Quote provided in the Proposal	subtract (-)	<u>20,000.00</u>	B
Subtotal	equals (=)	<u>\$ 1,980,000.00</u>	
Changes to Inventory Adjustment Factor <i>(Assumes 1% increase. Equals 1 + 0.01000)</i>	multiply (x)	1.01000	C
Price Adjustment Factor <i>(refer to Appendix 2, sample calculation for Contract Year 2)</i>	multiply (x)	0.97423	D
Annual Insurance Premium Quote for the First Contract Year	add (+)	20,000.00	B
Adjusted Annual Price before insurance and Routine Maintenance Service charges	equals (=)	<u>\$ 1,968,265.15</u>	
New Insurance Premium Quote (Contract Year 2)		22,000.00	
Less: Insurance Premium Quote provided in the Proposal		<u>20,000.00</u>	
Total difference in Insurance Premium Quote		2,000.00	
Insurance Premium Adjustment Value <i>(\$2,000 x 0.80 = \$1,600)</i>	add (+)	\$ 1,600.00	E
Changes to Routine Maintenance Services, if applicable <i>(based on an assumed \$3,000 <u>increase</u> in services)</i>	add (+) or subtract (-)	<u>3,000.00</u>	F ⁽¹⁾
Adjusted Annual Price	equals (=)	<u>\$ 1,972,865.15</u>	

The numbers used in this sample calculation are for illustrative purposes only.

APPENDIX 3 (TO SCHEDULE 7) - CONTINUED
SAMPLE ADJUSTED ANNUAL PRICE CALCULATION
FOR CONTRACT YEAR 3

<u>Description</u>	<u>Action</u>	<u>Amount</u>	<u>Ref.</u>
Adjusted price for the preceding Contract Year (Contract Year 2)		\$ 1,972,865.15	A
Annual Insurance Premium Quote for the preceding Contract Year (Contract Year 2)	subtract (-)	22,000.00	B
Changes to Routine Maintenance Services, if applicable (based on an assumed \$1,000 <u>decrease</u> in services)	add (+) or <u>subtract (-)</u>	<u>1,000.00</u>	F ⁽²⁾
Subtotal	equals (=)	<u>\$ 1,949,865.15</u>	
Changes to Inventory Adjustment Factor (Assumes 1% increase. Equals 1 + 0.01000)	multiply (x)	1.01000	C
Price Adjustment Factor (refer to Appendix 2, sample calculation for Contract Year 3)	multiply (x)	1.02585	D
Annual Insurance Premium Quote for the immediately preceding Contract Year (Contract Year 2)	add (+)	22,000.00	B
Adjusted Annual Price before insurance charges	equals (=)	<u>\$ 2,042,271.86</u>	
New Insurance Premium Quote (Contract Year 3)		21,000.00	
Less: Preceding Year Insurance Premium Quote (Contract Year 2)		<u>22,000.00</u>	
Total difference in Insurance Premium Quote		-1,000.00	
Insurance Premium Adjustment Value (-\$1,000 x 0.80 = -\$800)	add (+)	\$ -800.00	E
Adjusted Annual Price	equals (=)	<u>\$ 2,041,471.86</u>	

The numbers used in this sample calculation are for illustrative purposes only.

APPENDIX 4 (TO SCHEDULE 7) – INVENTORY CHANGE DETAIL FORM

Contract Year @@ Inventory Change Detail
Lower Mainland East Electrical Service Area

Location		Action		Description	Date
Main Street	Cross Street	Add	Remove		
Fully actuated signalized intersection					
	TOTAL	0	0		
Pedestrian actuated signal					
	TOTAL	0	0		
Pedestrian actuated flasher (special x-walks / solar powered) / fire signal					
	TOTAL	0	0		
Overhead Flashing Beacon					
	TOTAL	0	0		
Post mounted flasher					
	TOTAL	0	0		
Overhead warning sign with flashers					
	TOTAL	0	0		
Solar powered island flasher					
	TOTAL	0	0		
Solar powered overhead warning sign with flashers					
	TOTAL	0	0		
Street, roadway, area and sign lighting (luminaires)					
	TOTAL	0	0		
Permanent traffic count stations / ATIS cabinet					
	TOTAL	0	0		
Uninterruptible Power Supply (UPS)					
	TOTAL	0	0		
Web camera					
	TOTAL	0	0		

Remote web camera (greater than 250km one way from Base Location)					
	TOTAL	0	0		
Solar powered web camera					
	TOTAL	0	0		
Remote solar powered web camera (greater than 250km one way from Base Location)					
	TOTAL	0	0		
Bluetooth reader					
	TOTAL	0	0		
Rest area Wi-Fi power					
	TOTAL	0	0		
Solar powered units					
	TOTAL	0	0		
LED and flip disk dynamic message sign (also refer to as changeable message sign CMS)					
	TOTAL	0	0		
Highway Open / Closed					
	TOTAL	0	0		
LED chevron sign					
	TOTAL	0	0		
Speed feedback sign					
	TOTAL	0	0		
LED W-064 Watch for Wild Animal sign					
	TOTAL	0	0		
Overheight detection system					
	TOTAL	0	0		
Electric vehicle charging station					
	TOTAL	0	0		
Remote electric vehicle charging station (greater than 250 km one way from base location)					
	TOTAL	0	0		
69kV transformer station					
	TOTAL	0	0		

NOTE: This form is to be submitted in accordance with Section 19.4(a).

SCHEDULE 8 – ADDITIONAL SERVICES

1. Definitions

1.1 In this Schedule, unless the context otherwise requires:

- (a) **"Additional Services"** means all work initiated and authorized by Work Order and includes both Guaranteed Additional Services and Other Additional Services;
- (b) **"Changed Condition(s)"** means surficial or subsurface conditions at the Site materially different from those indicated in the Work Order which could not be reasonably foreseen by a reasonably experienced electrical maintenance contractor who conducted a thorough investigation and inspection of the Site and reviewed all Site specific reference information made available by the Province, but does not include any change in quantities or any change to the surficial or subsurface conditions caused by the weather or any natural event;
- (c) **"Commissioning"** means all work necessary to energize any traffic signal controller at a new or modified installation pursuant to the Traffic Controller Design Manual as published by the Province and as may be updated from time to time;
- (d) **"Guaranteed Additional Services"** means the following work initiated and authorized by the Province's Work Order:
 - (i) all final electrical terminations required to energize new and/or modified traffic signal equipment at an existing traffic signal, including luminaires connected to the signals service panel;
 - (ii) Commissioning of all traffic signals on Ministry roadways as per section 400 of the *Traffic Controller Design Manual* May 2019, (as may be amended by the Province from time to time during the Term,) including new traffic signals, modification to existing traffic signals, and replacement of traffic controllers, for greater certainty portable signals are not included;
 - (iii) collection of controller volume and MOE logs as requested by the Ministry following the guidelines outlined in section 500 of the *Traffic Controller Design Manual* May 2019, (as may be amended by the Province from time to time during the Term,) over and above the 60% total pedestrian and traffic signal Inventory number to be collected under Routine Maintenance Services;
 - (iv) implementation of traffic signal timing plans as per section 500 of the *Traffic Controller Design Manual* May 2019, (as may be amended by the Province from time to time during the Term,) over and above the 100% of the pedestrian and traffic signal Inventory number to be implemented under Routine Maintenance Services;
 - (v) installation of temporary one way bridge signal equipment, for greater certainty portable signals are not included;
 - (vi) modification of existing field operational temporary one way bridge signal equipment;
 - (vii) Commissioning of all temporary one way bridge signals on Ministry roadways as per section 500 of the *Traffic Controller Design Manual* May 2019, (as may be amended by the Ministry from time to time during the Term.), for greater certainty portable signals are not included;
 - (viii) supply and installation of uninterruptible power supplies, complete with cabinets, at traffic signals only; and

- (ix) all temporary revision to signal operations and lighting for special events, including but not limited to sporting events, filming and wide load transportation, as required.
- (e) **"Other Additional Services"** means work initiated and authorized by Work Order other than Guaranteed Additional Services and includes but is not limited to:
 - (i) Supply and installation of conduit, concrete bases, vaults, and concrete or plastic junction boxes;
 - (ii) Supply and installation of luminaire poles, signal poles, sign poles, post mounted flashers, traffic controllers and service equipment;
 - (iii) Supply and installation of wiring;
 - (iv) Removal and disposal of concrete and asphalt;
 - (v) Supply and installation of detector loops for traffic signals;
 - (vi) Installation of concrete sidewalks, concrete curbs, traffic and median islands and asphalt concrete pavement for electrical work;
 - (vii) Removal of existing electrical equipment;
 - (viii) Installation of short count and permanent count traffic stations;
 - (ix) Installation of webcams, speed reader boards and changeable message signs, etc.;
 - (x) Drilling and pushing;
 - (xi) Inspection of third party electrical installations; and
 - (xii) Miscellaneous electrical work as, if and when required.
- (f) **"Site"** means the area within the Electrical Service Area identified or referenced in the Work Order;
- (g) **"SSHC"** and **"Standard Specifications"** means the Standard Specifications for Highway Construction as updated on the Province's website from time to time; and
- (h) **"Work Order"** means a written order issued by the Province to the Contractor, in the form attached as Appendix 2 to this Schedule and as may be amended by the Province from time to time, requiring the Contractor to perform Additional Services as agreed upon by both Parties. Notwithstanding the foregoing, where the Parties do not reach agreement on the Work Order for Additional Services, the Work Order may become a directive from the Province to the Contractor to perform the Additional Services with the payment of such work being determined pursuant to Section 3.1 of this Schedule.

1.2 All other capitalized words and phrases will have the meaning ascribed to them in the Agreement.

2. Additional Services

2.1 Provided the Contractor is not in material breach of this Agreement, the Province will provide, by way of Work Order, all Guaranteed Additional Services to the Contractor, and not to another contractor, and the Contractor will be required to perform the Guaranteed Additional Services.

2.2 Guaranteed Additional Services will not be undertaken by the Contractor unless authorized by a written Work Order issued and executed by the Province.

- 2.3 The Contractor will invoice the Province with accompanying supporting documentation (including but not limited to invoices, receipts, bills of lading, work orders and the certificate referenced in Section 3.11 herein) within 30 days of fully completing the Additional Services. In the event the Contractor fails to submit an invoice for reimbursement within 30 days of final completion of this work, the Contractor may no longer be entitled to reimbursement from the Province pursuant to this Schedule at the Province's discretion.
- 2.4 The Province makes no guarantee, representation or warranty of any kind on the amount of Additional Services that the Province will be requiring from the Contractor during the Term.
- 2.5 The Province makes no guarantee, representation or warranty of any kind as to whether the Province will use the Contractor to perform any Other Additional Services during the Term of the Agreement.
- 2.6 The Province reserves the right to:
- (a) direct the Contractor to perform Other Additional Services by way of Work Order pursuant to Section 3.1 below;
 - (b) utilize another contractor to perform Other Additional Services;
 - (c) complete Other Additional Services by its own forces; or
 - (d) upon providing notice to the Contractor, utilize another contractor to complete Other Additional Services that are commenced by the Contractor.

3. Work Orders

- 3.1 Upon the request of the Province, the Contractor shall provide a detailed written estimate including, but not limited to, labour, equipment, materials, and subcontractors to the Province for the Additional Services. The parties may negotiate on the Contractor's estimate and on the basis of payment listed in Section 3.2 of this Schedule. The Contractor will obtain the best value for money when procuring any work, services, supplies, materials or equipment and will hold itself to a standard for the procurement that is no less than good industry practice.
- 3.2 The basis for the payment of Additional Maintenance shall be:
- (a) a price calculated in accordance with Appendix 1 (Cost Plus Rates) of this Schedule; or
 - (b) a lump sum price agreed by the Parties.
- 3.3 The Contractor will not commence work pursuant to a Work Order for Additional Services involving new installations or modifications until the Province delivers to the Contractor a design that is stamped by a professional engineer (P. Eng) or as approved by the Province to proceed, as the case may be.
- 3.4 The Contractor must complete the work in accordance with the terms of the Work Order.
- 3.5 The Contractor must utilize a material supplier that is arm's length from the Contractor for the purposes of Section 3.1 herein. Arm's length means that there is no connection arising directly or indirectly through the ownership or holding of shares or other equity interests, including the ownership or holding by the Contractor of shares or other equity interests in the material supplier.
- 3.6 The Province may require a work schedule from the Contractor for Work Orders over \$5,000.00. The work schedule will describe the planned sequence of work from start to completion and will be submitted to the Province and approved prior to the Contractor starting work.

- 3.7 Where the completion of Additional Services has been delayed because of a delay to the supply of materials or a delay caused by a utility company, municipality or other third party, the Province will either grant the Contractor a time extension or terminate the Work Order and hire another contractor to perform or complete the Additional Services.
- 3.8 The Contractor will give the Province notice of a Changed Condition within 5 Working Days' of that Changed Condition.
- 3.9 If the Province determines that a Changed Condition has arisen, and such Changed Condition would cause an increase or decrease in either the costs to be incurred by the Contractor or in the time required to perform the Additional Services, the Province may enter into a supplemental Work Order by mutual agreement with the Contractor adjusting the payment required for the performance of the Additional Services or adjusting the time required to perform the Additional Services.
- 3.10 With respect to a Changed Condition claim, the Contractor will not claim for that portion of the costs which could have been avoided by the Contractor.
- 3.11 If a requirement for field reviews is included in the Work Order, the Contractor shall complete and execute the "Assurance of Field Reviews and Compliance H-1254" as a requirement for final acceptance and payment of those works by the Province.

4. Pre-Construction and Progress Meetings

- 4.1 The Contractor must attend, at the Province's request, a pre-construction meeting with the Province and all interested parties (including but not limited to local governments and developers), prior to the commencement of the Additional Services.
- 4.2 Progress meetings will be held at the discretion of the Province.
- 4.3 The Contractor will not be entitled to payment from the Province for the Contractor's attendance at pre-construction and progress meetings.

5. Standards for Additional Services

- 5.1 Unless otherwise directed in writing by the Province to the Contractor, the current version of the Standard Specifications for Highway Construction will apply to the performance of Additional Services by the Contractor, with the exception of the payment provisions in the Standard Specifications for Highway Construction which will not apply, as payments to the Contractor are in accordance with this Schedule and its Appendix.

APPENDIX 1 (TO SCHEDULE 8) - COST PLUS RATES

1. General

- 1.1 Payment by the Province to the Contractor for Additional Services pursuant to subsection 3.2(a) of Schedule 8 ("Additional Services") shall be calculated in accordance with this Appendix and shall constitute full and final payment for all costs and expenses incurred by the Contractor in connection with providing the Additional Services.
- 1.2 Conditional upon the Province paying the Contractor is the receipt, to the Province's satisfaction, of the following supporting documentation:
- (a) for labour: include time cards showing employee job designation, rate, hours worked, location of work and activity (type of work);
 - (b) for purchased materials: include invoices from the supplier that include the item description, quantity, unit cost, and total cost;
 - (c) for materials from own inventory: include three quotes for same/similar material to determine market price, including shipping and delivery charges;
 - (d) for hired equipment: invoices include the type, make, model, size, year, attachments, rate (as defined in the most recent edition of the "Equipment Rental Rate Guide" (The Blue Book) published by the B.C. Road Builders & Heavy Construction Association), and hours worked;
 - (e) for subcontracts: include a copy of the agreement; and;
 - (f) for food and lodging payable only at the Group 1 provincial government per diem rates: include the name of employees, hours worked, location of work and receipt for accommodation. Meal receipts are not required.

2. Labour

2.1 Cost Plus Rates for labour, subject to the terms of this Agreement, shall be:

- (a) an amount equal to actual wages and salaries, including payroll burden, incurred directly by the Contractor in respect of the Contractor's labour and supervisory personnel who are actively and necessarily engaged on the particular item of work performed by the Contractor, which is based on:
 - (i) where applicable, the collective agreement in force between the Contractor and the trade union representing the employees of the Contractor that is in effect, voluntarily recognized, or certified pursuant to the Labour Relations Code of British Columbia; or
 - (ii) where there is no collective agreement, the Contractor's actual costs for wages and salaries certified in writing by the Contractor to the satisfaction of the Province,

supported by recorded time and hourly rates of pay for that labour and supervision.

For clarity, payroll burden includes, but is not limited to, the following costs paid by the employer: vacation pay, sick leave, statutory holidays, training, employment insurance, group life insurance, Medical Services Plan of British Columbia, group medical plan, WorkSafe BC, pension plan, Canada Pension Plan and union contributions; and

- (b) 20% of the total costs calculated under subsection 2.1(a) of this Appendix to cover the Contractor's profit and any and all other costs of the Contractor, including without limitation, the Contractor's overhead, supervision, administration, insurance and bonding costs and other expenses.
- 2.2 The Cost Plus Rates for labour calculated in Section 2.1(a) shall not include:
 - (a) any payment or costs incurred by the Contractor for operators of hired equipment, as described in the Province's Hired Equipment Policy;
 - (b) labour costs incurred by the Contractor in connection with or under subcontracts; or
 - (c) costs incurred by the Contractor for general supervision, administration, or management time spent on the item of work.
- 3. **Equipment**
- 3.1 Cost Plus Rates for equipment shall, subject to the terms of this Agreement, be an amount equal to the total of subsections 3.1(a), 3.1(b) and 3.1(c) of this Appendix:
 - (a) costs for equipment owned or leased by the Contractor shall be an amount equal to the applicable "All Found Less Operator" rate plus the fuel surcharge set out in the most recent edition of the "Equipment Rental Rate Guide" (The Blue Book) published by the B.C. Road Builders & Heavy Construction Association and authorized by the Province, in effect when that item of work was performed, or, if the "Equipment Rental Rate Guide" (The Blue Book) published by the B.C. Road Builders & Heavy Construction Association is silent as to the applicable rate, the rate shall be agreed upon by the Province and the Contractor prior to the use of the equipment in the performance of the applicable item of work, being full payment and reimbursement for all fuel, oil, lubrication, repairs, maintenance, and other costs incidental to owning and operating the equipment;
 - (b) costs for hired equipment shall be an amount equal to the applicable "All Found" rate plus the fuel surcharge set out in the most recent edition of the "Equipment Rental Rate Guide" described in subsection 3.1(a) above, in effect when that item of work was performed, or, if the most recent edition of the "Equipment Rental Rate Guide" published by the B.C. Road Builders & Heavy Construction Association is silent as to the applicable rate, the rate shall be agreed upon by the Province and the Contractor prior to the use of the equipment in the performance of the applicable item of work, being full payment and reimbursement for the operator, and for all fuel, oil, lubrication, repairs, maintenance, and other costs incidental to owning and operating the equipment;
 - (c) a general northern allowance of 10% of the total calculation of 3.1(a) and (b) for Haida Gwaii, Highway 97 north of Pink Mountain and Highway 37 north of Cranberry 2 Bridge;
 - (d) 15% of the total costs calculated under subsections 3.1(a), 3.1(b) and 3.1(c) of this Appendix to cover the Contractor's profit, and any and all other costs of the Contractor, including without limitation, the Contractor's overhead, supervision, administration, insurance and bonding costs and other expenses.
- 3.2 The Cost Plus Rates for equipment shall not include fees for equipment incurred by the Contractor in connection with or under subcontracts.

4. Materials

4.1 The Cost Plus Rates for materials purchased or supplied from stock that are necessary to carry out the work shall subject to the terms of this Agreement, be an amount equal to the total of subsections 4.1(a) and 4.1(b) of this Appendix:

- (a) the actual costs incurred by the Contractor for materials supplied in the performance of the applicable item of work at invoice costs (which includes all freight and express charges, all taxes excluding GST, and all other costs incurred by the Contractor to supply the materials delivered and used to perform the applicable item of work, at the site) or the market price for materials from the Contractor's own inventory (as evidenced by 3 quotes); and
- (b) 10% of the total costs calculated under subsection 4.1(a) of this Appendix to cover the Contractor's profit, and any and all other costs of the Contractor, including without limitation, the Contractor's overhead, supervision, administration, insurance and bonding costs and other expenses.

4.2 Cost Plus Rates for materials shall not include fees for materials incurred by the Contractor in connection with or under subcontracts.

5. Subcontracts

5.1 Cost Plus Rates for subcontracts necessary to carry out the work shall, subject to the terms of this Agreement, be an amount equal to the total of subsections 5.1(a) and 5.1(b) of this Appendix:

- (a) the actual costs incurred by the Contractor for subcontracts with subcontractors in the performance of the applicable item of work at invoice costs (which includes all taxes paid by the subcontractor and the Contractor); and
- (b) 10% of the total costs calculated under subsection 5.1(a) of this Appendix to cover the Contractor's profit, and any and all other costs of the Contractor including without limitation, the Contractor's overhead, supervision, administration, insurance and bonding costs and other expenses.

5.2 For the purpose of this Schedule, a "subcontract" is a contract between the Contractor and a third party for the purpose of the third party performing Additional Maintenance Services pursuant to this Agreement and does not include an equipment lease or hiring of equipment.

APPENDIX 2 (TO SCHEDULE 8) – WORK ORDER FORM

 BRITISH COLUMBIA	Ministry of Transportation and Infrastructure	<h2 style="margin:0;">ELECTRICAL OPERATIONS WORK ORDER FORM</h2>	WO# 2019 100																					
ISSUED BY: Ministry Electrical Services Coordinator Electrical Services Transportation and Infrastructure Region: Address 1: Address 2: Address 3: E-Mail: Phone:	ISSUED TO: Contractor name XXX Attention: Address 1: Address 2: Address 3: E-Mail: Phone:																							
Signature of Issuer: _____		DATE OF ISSUE: <table border="1" style="display: inline-table; border-collapse: collapse;"> <tr> <td style="width: 20px;">YEAR</td> <td style="width: 20px;">MONTH</td> <td style="width: 20px;">DAY</td> </tr> <tr> <td style="height: 20px;"></td> <td></td> <td></td> </tr> </table>	YEAR	MONTH	DAY																			
YEAR	MONTH	DAY																						
Electrical Maintenance Contract #: _____		DATE REQUIRED: <table border="1" style="display: inline-table; border-collapse: collapse;"> <tr> <td style="width: 20px;">YEAR</td> <td style="width: 20px;">MONTH</td> <td style="width: 20px;">DAY</td> </tr> <tr> <td style="height: 20px;"></td> <td></td> <td></td> </tr> </table>	YEAR	MONTH	DAY																			
YEAR	MONTH	DAY																						
STEP 1 - Scope of Work: Work Description: (Be as detailed as possible - attach information as required)																								
STEP 2 - Contractor Summary Estimate Detailed breakdown required? (if yes, contractor complete Estimate form) <input type="checkbox"/> No <input type="checkbox"/> Yes Payment Details: (Approved by the Ministry) <input type="checkbox"/> Cost Plus <input type="checkbox"/> Lump Sum Field Review Required? (if yes, contractor complete H-1254 form) <input type="checkbox"/> No <input type="checkbox"/> Yes		<table border="1" style="width:100%; border-collapse: collapse;"> <thead> <tr> <th style="width: 80%;">Components</th> <th style="width: 20%;">Cost</th> </tr> </thead> <tbody> <tr><td>Labour:</td><td></td></tr> <tr><td>Equipment:</td><td></td></tr> <tr><td>Materials:</td><td></td></tr> <tr><td>Sub-contract:</td><td></td></tr> <tr><td>Food & Lodging:</td><td></td></tr> <tr><td>Miscellaneous:</td><td></td></tr> <tr style="font-weight: bold; color: red;"> <td>Total Cost</td> <td>\$0.00</td> </tr> </tbody> </table>	Components	Cost	Labour:		Equipment:		Materials:		Sub-contract:		Food & Lodging:		Miscellaneous:		Total Cost	\$0.00						
Components	Cost																							
Labour:																								
Equipment:																								
Materials:																								
Sub-contract:																								
Food & Lodging:																								
Miscellaneous:																								
Total Cost	\$0.00																							
Attach backup documentation. Do not exceed approved estimate* *A signed/approved revision is required if the original estimate is exceeded																								
STEP 3 - Signatories																								
<u>Ministry Representative</u>		<u>Contractor</u>																						
Signature: _____ Name: _____ Title: _____ Date: _____		Signature: _____ Name: _____ Title: _____ Date: _____																						
For Ministry Use Only (Ministry Representative to confirm limit with Expense Authority Matrix or Corporate Signing Authority System)																								
RESP <table border="1" style="width: 100%; border-collapse: collapse;"> <tr> <td style="width: 20px; height: 20px;"></td> <td style="width: 20px; height: 20px;"></td> <td style="width: 20px; height: 20px;"></td> <td style="width: 20px; height: 20px;"></td> <td style="width: 20px; height: 20px;"></td> </tr> </table>						S/L <table border="1" style="width: 100%; border-collapse: collapse;"> <tr> <td style="width: 20px; height: 20px;"></td> <td style="width: 20px; height: 20px;"></td> <td style="width: 20px; height: 20px;"></td> <td style="width: 20px; height: 20px;"></td> <td style="width: 20px; height: 20px;"></td> </tr> </table>						STOB <table border="1" style="width: 100%; border-collapse: collapse;"> <tr> <td style="width: 20px; height: 20px;"></td> <td style="width: 20px; height: 20px;"></td> <td style="width: 20px; height: 20px;"></td> <td style="width: 20px; height: 20px;"></td> <td style="width: 20px; height: 20px;"></td> </tr> </table>						PROJECT NO. <table border="1" style="width: 100%; border-collapse: collapse;"> <tr> <td style="width: 20px; height: 20px;"></td> <td style="width: 20px; height: 20px;"></td> <td style="width: 20px; height: 20px;"></td> <td style="width: 20px; height: 20px;"></td> <td style="width: 20px; height: 20px;"></td> </tr> </table>						<input type="checkbox"/> Multi-line coding attached
CPS																								
_____ Product/Info 1	_____ Business Type	_____ Work Activity/Info 2	_____ Cost Type/Info 3																					

SCHEDULE 9 – PRIME CONTRACTOR DESIGNATION

HIGHWAY CONSTRUCTION PROJECTS

1. This Schedule relates to the responsibility for communication, information concerning the Prime Contractor designation and responsibility for coordination of activities, responsibility for maintenance activities within the limits of construction, and responsibility for incident response activities within the limits of construction as between the Prime Contractor and the Contractor and the highway maintenance contractor.
2. **Responsibilities for Communication**
 - 2.1 It is imperative that communication occurs between the Contractor, the highway maintenance contractor and construction contractor(s) at the startup of a construction job and contact information and responsibilities be discussed ahead of any on site construction activities taking place. These contractors and the Province's District Operations Manager and Ministry Representative will have a pre-construction meeting to review the responsibilities of each. The details of the construction contract (the work, the construction schedule, and so forth) and the times and conditions of scheduled shutdowns will be communicated to the Contractor and the highway maintenance contractor. 24 hour contact numbers for all key personnel need to be exchanged.
3. **Prime Contractor Designation and Responsibility for Coordination of Activities**
 - 3.1 The construction contractor is the Prime Contractor with respect to WorkSafeBC safety purposes and is responsible for the coordination of occupational health and safety issues of all employers for the limits of construction. That responsibility is inherent whether there are active construction activities on site or if the construction contractor has temporarily shut down activities for the evening weekend, or other short time period. The Contractor and the highway maintenance contractor doing work within the limits of construction must coordinate their activities with the Prime Contractor's coordinator.
 - 3.2 On a highway construction project with more than one construction contractor contracted with the Province, the Province may designate one or more areas of responsibility (which together will encompass all the construction activities) each with one Prime Contractor. The areas and Prime Contractor designations will be confirmed at the pre-construction meeting.
4. **Responsibility for Maintenance Activities within the Limits of Construction**
 - 4.1 The highway construction project does not relieve the Contractor and the highway maintenance contractor of their respective responsibilities for maintenance activities within the limits of construction unless the Province has provided the Contractor and the highway maintenance contractor with a written notice that removes the inventory from the maintenance contracts, pursuant to the terms of these contracts.
 - 4.2 The construction contract places the obligation on the construction contractor for the maintenance of the "Disturbed Features" only. In practice, this means the construction contractor shall have maintenance obligations for Disturbed Features in the limits of construction. The construction contractor shall be permitted to provide those services in-house, to subcontract to the Contractor or the highway maintenance contractor or to another subcontractor (at the construction contractor's

cost), with the exception that maintenance on electrical controllers shall only be performed by the electrical maintenance contractor (at the construction contractor's cost).

- 4.3 General Condition 26.01 of the Major Works contract relieves the construction contractor of routine winter maintenance services where roadways are open to the public, whether the feature has been "disturbed" or not. However, General Condition 26.01 of the Major Works contract can be modified by the Province pursuant to General Condition 26.02 – 26.04.

5. **Responsibility for Incident Response Activities within the Limits of Construction**

- 5.1 When the construction contractor is on site and working, and an incident (including, but not limited to, a motor vehicle accident or other emergency situation) arises within the limits of construction, the construction contractor shall respond immediately to the situation. In such instances, the construction contractor shall inform Transportation Management Centre of British Columbia (TMCBC) of the incident and of any anticipated delays or traffic obstructions and shall update TMCBC as conditions on the site change and when the scene has been cleared and normal traffic flow reestablished so that timely and accurate information can be provided to the public.
- 5.2 During construction shutdown periods (whether overnight, weekends, or for a more extended period of time), the Prime Contractor shall ensure that Disturbed Features are made safe. The construction contractor shall provide patrol services for Disturbed Features to ensure traffic control devices are in place and properly functioning, and arrangements must be made to ensure emergencies, which could impact the safety of the travelling public, are responded to effectively and efficiently. The construction contractor shall be permitted to provide those services in-house, to subcontract to the Contractor or highway maintenance contractor or to another subcontractor (all at the construction contractor's cost).
- 5.3 In the event of an incident (including but not limited to, a motor vehicle incident or other emergency situation) arises within the limits of construction, the TMCBC contacts the construction contractor during normal working shifts, and either the Contractor or the highway maintenance contractor (as applicable) after-hours or when construction is suspended or during shutdown periods. If either the Contractor or the highway maintenance contractor is first to respond and determines that the incident relates to a Disturbed Feature, the Contractor or the highway maintenance contractor (as applicable) may contact the construction contractor who will take over the response.
- 5.4 Response activities for an incident (including, but not limited to, a motor vehicle incident or other emergency situation) that does not involve Disturbed Features shall be the responsibility of the Contractor or the highway maintenance contractor (as applicable) when the construction contractor is not on site. In such instances, the Contractor or the highway maintenance contractor (as applicable) shall inform TMCBC of the incident and of any anticipated delays or traffic obstructions and shall also update the TMCBC as conditions on the site change and when the scene has been cleared and normal traffic flow reestablished so that timely and accurate information can be provided to the public.

SCHEDULE 10 – DISPUTE RESOLUTION PROTOCOL

1. The Contractor and the Province will meet to discuss and attempt to resolve the dispute.
2. If there is no resolution within 5 Working Days of this meeting, the Contractor will set out its position and proposed resolution in writing, stating the applicable articles of the Electrical Maintenance Services Agreement involved, and forward this to the local Regional Director.
3. The Regional Director, on behalf of the Province, must provide a written response within 10 Working Days of receipt of the Contractor's proposal. This response must either:
 - (a) Indicate agreement with the Contractor's position and proposed resolution; or
 - (b) Propose an alternative to the Contractor's resolution with written reasons for the alternative; or
 - (c) Reject the Contractor's resolution with written reasons for the rejection.
4. If the Province fails to provide a written response within this time period, the Contractor can immediately refer the matter to arbitration pursuant to Section 8, below.
5. If either Section 3(b) or 3(c) above occur, the Contractor may either accept the Province's response, or refer the matter to arbitration pursuant to Section 8, below.
6. Time limits may be extended by mutual written agreement, but extensions cannot exceed an additional 10 Working Days in total.
7. In the event the dispute is pursuant to a compensation adjustment resulting from a Change Order the parties, and the arbitrator if the dispute is arbitrated, will consider:
 - (a) service level changes relative to existing obligations under this Agreement;
 - (b) the practical effect of the change on the business operations of the Contractor, including direct cost increases and decreases and the indirect cost of a reduction in the Services without a corresponding reduction in fixed and overhead costs; and
 - (c) whether in the aggregate, a change in compensation will result in an improvement or deterioration in the Contractor's financial condition, and the provisions of this Agreement.
8. All disputes arising under this Agreement will first follow the escalation procedure set forth above, and if unresolved, then the dispute may be referred to and finally resolved by arbitration pursuant to the *Arbitration Act*, R.S.B.C. 1996, c.55 by written notice from one party to the other. The place of arbitration will be Victoria, British Columbia.

SCHEDULE 11 – EQUIPMENT FLEET OPERATIONS POLICY

The equipment requirements in this Schedule (which, for greater certainty, includes the appendices attached hereto) are the minimum standards for the operation of the Contractor's equipment fleet. This Schedule applies to vehicles and equipment (including both Contractor-owned, leased, subcontracted, hired or rented vehicles and equipment) used by the Contractor in the performance or inspection of activities related to performing the Services, including vehicles and equipment used to transport workers to and from locations where Services are to be, or were, performed.

1. Definitions

1.1 In this Schedule, unless the context otherwise requires:

- (a) **"Stripes"** means retro reflective high conspicuity markings diamond grade ASTM 9 that are 3" in width in an alternating red and white pattern affixed directly onto Operational Vehicles and Equipment;
- (b) **"Surfaces"** means retro reflective high conspicuity markings hi-intensity grade ASTM 3 or diamond grade ASTM 9 in a checkerboard/chevron pattern of alternating colours affixed directly onto the rear of Operational Vehicles and Equipment; and
- (c) **"Operational Vehicles and Equipment"** means vehicles and equipment (including both Contractor-owned, leased, subcontracted or hired vehicles and equipment) used by the Contractor in the performance or inspection of activities related to performing the Services, including vehicles and equipment used to transport workers to and from locations where Services are to be, or were, performed.

2. General Requirements

2.1 Operational Vehicles and Equipment shall conform to Division 4 of the Motor Vehicle Act Regulations (B.C. Reg. 26/58).

2.2 Operational Vehicles and Equipment shall:

- (a) be painted at least 80% Sherwin-Williams school bus yellow or, if no longer available, a similar colour as selected by the Province, in its sole discretion;
- (b) have high conspicuity markings described in Section 3 of this Schedule; and
- (c) have the lighting described in Section 4 of this Schedule.

2.3 Operational Vehicles and Equipment shall display the Contractor's company identification which shall:

- (a) be retro reflective engineering grade ASTM 1 at a minimum; and
- (b) have lettering 50mm in height or greater; and
- (c) be placed in accordance with the Appendices hereto.

2.4 Contractors and their employees shall not use personal vehicles as Operational Vehicles or Equipment, unless the personal vehicles conform to the requirements outlined in this Schedule.

2.5 Leased, subcontracted, hired or rented Operational Vehicles and Equipment that is operating for:

- (a) less than 180 days in a calendar year, shall comply with the Traffic Management Manual for Work on Roadways; or

- (b) 180 days or more in a calendar, shall comply with all requirements of this Schedule, except the colour requirement in subsection 2.2(a) of this Schedule.

3. High Conspicuity Marking Requirements

- 3.1 Operational Vehicles and Equipment shall have Stripes on at least 70% of the body length and Surfaces (as shown in the Appendices hereto) on at least 70% of the rear width of the Operational Vehicle or Equipment.
- 3.2 Stripes shall be placed at a minimum of 1 meter above the ground level, as shown in the Appendices hereto.

4. Lighting Requirements

- 4.1 All Operational Vehicles and Equipment shall operate with a permanently mounted rotating beacon with 360 degree visibility as shown in the Appendices hereto.

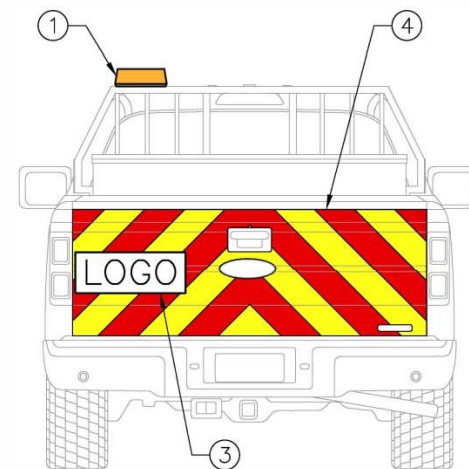
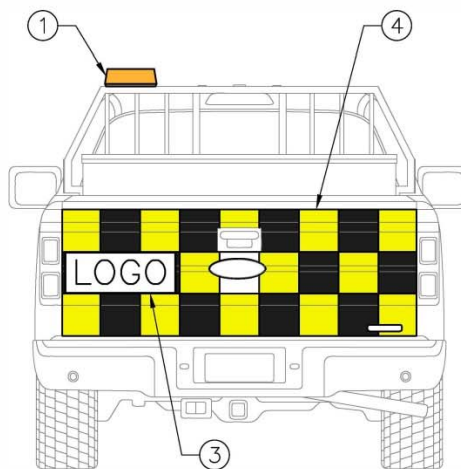
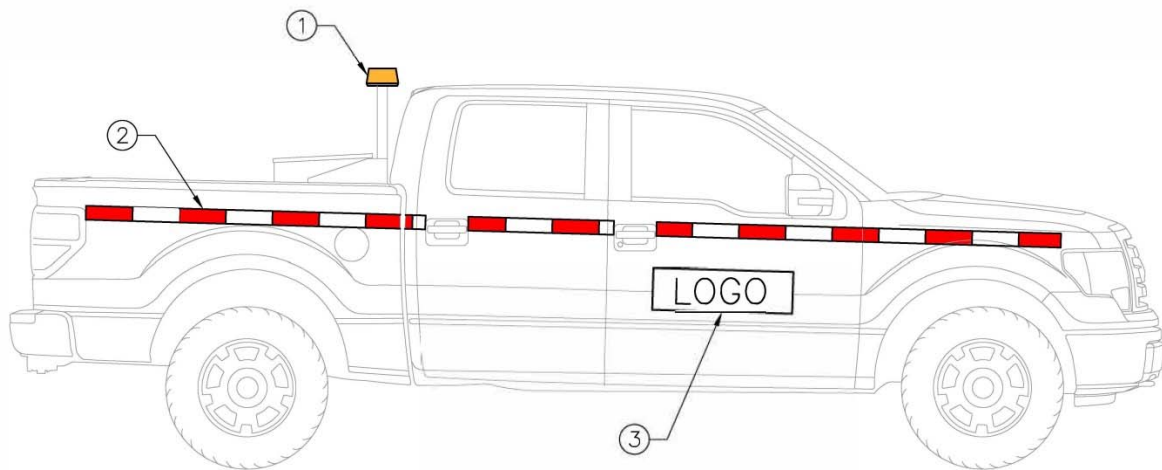

ITEM	DESCRIPTION
1	ROTATING BEACON
2	STRIPES
3	COMPANY IDENTIFICATION
4	SURFACE

SCALE N.T.S.		CAD FILENAME _____	
		DATE _____	
REV	DATE	REVISIONS	SIGNATURE



EQUIPMENT REQUIREMENTS
APPENDIX A
MAINTENANCE VEHICLE

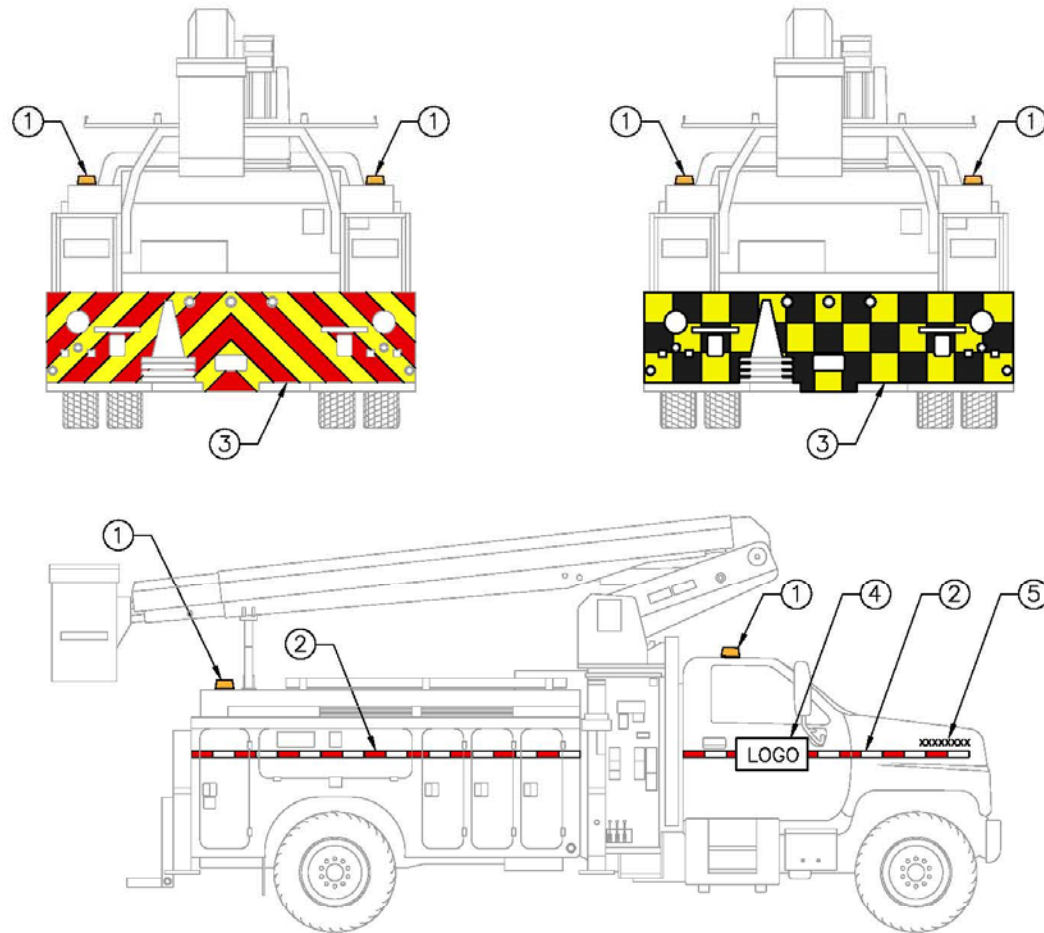

ITEM	DESCRIPTION
1	ROTATING BEACON
2	STRIPES
3	SURFACE
4	COMPANY IDENTIFICATION
5	UNIT NUMBER

SCALE N.T.S.		CAD FILENAME _____	
		DATE _____	
REV	DATE	REVISIONS	SIGNATURE



EQUIPMENT REQUIREMENTS
APPENDIX B
BUCKET TRUCK

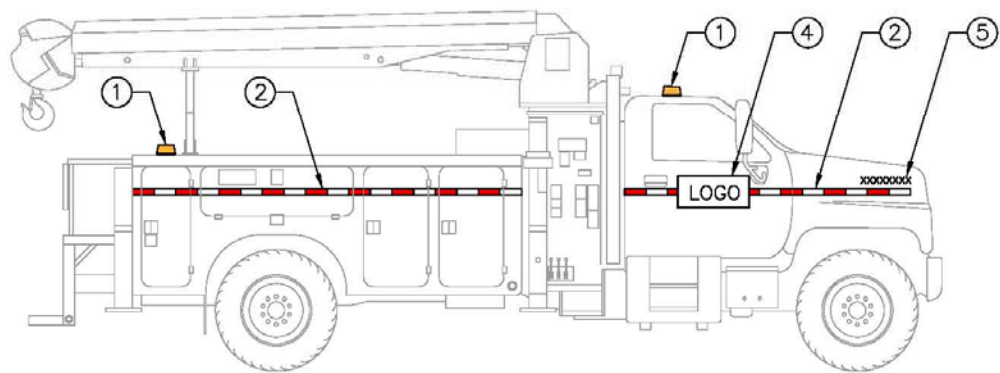
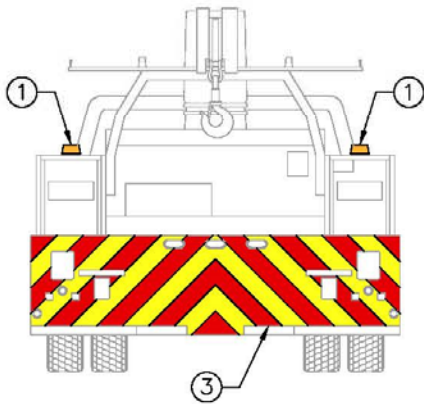
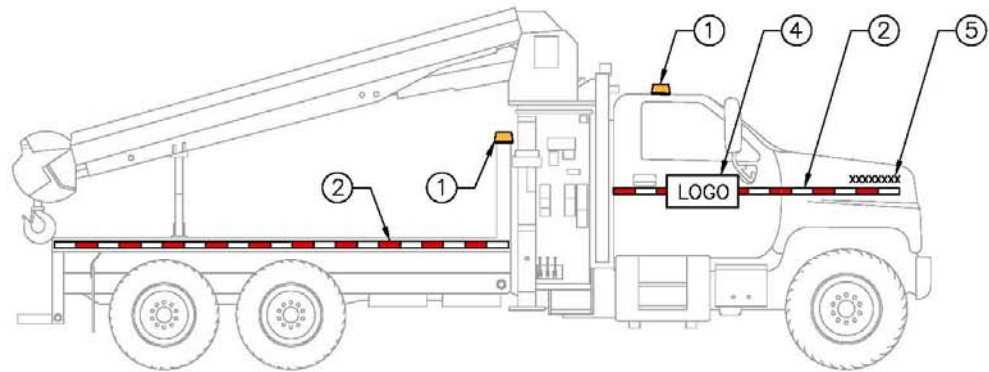
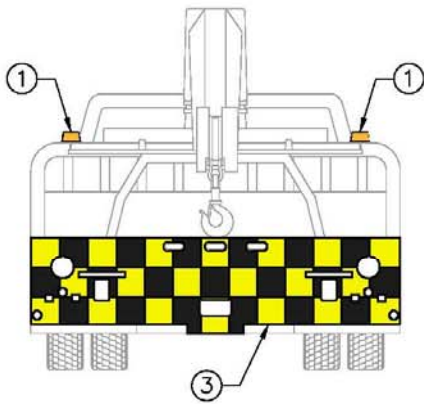

ITEM	DESCRIPTION
1	ROTATING BEACON
2	STRIPES
3	SURFACE
4	COMPANY IDENTIFICATION
5	UNIT NUMBER

SCALE N.T.S.		CAD FILENAME _____	
		DATE _____	
REV	DATE	REVISIONS	SIGNATURE



EQUIPMENT REQUIREMENTS
APPENDIX C
CRANE TRUCK

SCHEDULE 12 – REPEATER SYSTEM

1. **“Repeater System”** means the mountain-top radio equipment, control console equipment, telecommunications circuits, satellite back-up systems, and control room operating staff provided by the Province.
2. The Province will provide the Repeater System to the Contractor without charge for the use of the Contractor in performing the Services on the terms and conditions set out in this Schedule.
3. The Contractor will use the Repeater System solely for the purposes of performing the Services.
4. Any radio equipment owned by the Contractor and which may be used on the Repeater System will be approved by the Minister before being used on the Provider System.
5. Pursuant to Section 4 of this Schedule the Contractor will take all reasonable means to repair faulty radio equipment not owned by the Province which detrimentally affects the normal operation of the Repeater System.
6. The Repeater System will at all times remain the property of the Province.
7. The Province will, at the Province's expense, provide routine maintenance of the Repeater System as the Minister in the Minister's sole discretion may consider necessary from time to time.
8. The Province may replace the Repeater System or any part of the Repeater System which the Minister determines, in the Minister's sole discretion, has exceeded its useful life expectancy.
9. The Contractor will ensure that all of its radio equipment operating on the Repeater System is licensed to operate by Innovation Science and Economic Development Canada (ISED).
10. The Contractor will use radios on the Repeater System which have the following specifications:
 - Operating frequency 142-150Mhz
 - Maximum power output of 50W
 - Sub audible tone capable (CTCSS)
 - Narrow band channel spacing
 - Minimum of 24 channels
 - 12 button DTMF key pad
 - Transmitter time-out timer
 - Type approval from ISED Canada

SCHEDULE 13 – PROVINCIAL MATERIAL LIST

LOWER MAINLAND EAST ELECTRICAL SERVICE AREA

Quantity	Item Description
	Traffic Controller Components
3	Traffic Controller Mainframes (LMD 8000)
3	Conflict Monitors
1	NEMA TS2 – Type P6 Traffic Controller Cabinet
1	NEMA TS1 – Type S Traffic Controller Cabinet
1	NEMA TS1 – Type M-Rack Traffic Controller Cabinet
3	NEMA TS2 – Cobalt Traffic Controller

SCHEDULE 14 – BONDS

SPECIMEN SET - BONDS LABOUR AND MATERIAL PAYMENT BOND (British Columbia Government Form)

No. \$1,230,000

Note: This Bond is issued simultaneously with a Performance Bond in favour of the Obligee conditioned for the full and faithful performance of the contract.

KNOW ALL PERSONS BY THESE PRESENTS, that CONTRACTOR'S NAME as Principal, (the "Principal"), and Surety / Insurance Company or Companies name(s) and address(es), a corporation or corporations created and existing under the laws of Canada, and duly authorized to transact the business of suretyship in Canada, as Surety (the "Surety" if one surety is named in this Bond and the "Co-Sureties" if more than one), is/are held and firmly bound, jointly and severally in the case of Co-Sureties, unto HER MAJESTY THE QUEEN IN RIGHT OF THE PROVINCE OF BRITISH COLUMBIA AS REPRESENTED BY THE MINISTER RESPONSIBLE FOR THE TRANSPORTATION ACT, as obligee, (the "Obligee"), for the use and benefit of the Claimants (defined below), their and each of their heirs, executors, administrators, successors and assigns, in the amount of One Million Two Hundred Thirty Thousand Dollars (\$1,230,000) of lawful money of Canada (the "Bond Amount"), for the payment of which sum, well and truly to be made, the Principal and the Surety, or Co-Sureties, as the case may be, bind themselves, their heirs, executors, administrators, successors and assigns, jointly and severally, firmly by these presents.

WHEREAS, the Principal has entered into a multi-year contract with the Obligee, dated the @ day of @ 20@@ for Electrical Maintenance Service Agreement Lower Mainland eAST Electrical Service Area, (the "Contract") for a five (5) year term from September 1, 2021 (the "Commencement Date") to August 31, 2026 (the "Expiry Date") (the "Contract Term") that may be extended for a further five year period to August 31, 2031 (the "Contract Renewal Term") all in accordance with its provisions, and which document is incorporated by reference as part of this Bond;

AND WHEREAS, concurrently with the issuance of this Bond, the Surety has issued a Performance Bond which names Her Majesty the Queen in Right of the Province of British Columbia as represented by the Minister Responsible for the Transportation Act, as Obligee (the "Performance Bond").

NOW, THEREFORE, THE CONDITIONS OF THIS OBLIGATION are such that, if the Principal shall make payment to all Claimants for all labour and material used or reasonably required for use in the performance of the Contract then this obligation shall be null and void; otherwise it shall remain in full force and effect, subject, however, to the following conditions:

1. A Claimant for the purpose of this Bond is defined as one having a direct contract with the Principal for labour, material, or both, used or reasonably required for use in the performance of the Contract, labour and material being construed to include that part of water, gas, power, light, heat, oil, gasoline, telephone service or rental equipment directly applicable to the Contract; provided that a person, firm or corporation who rents equipment to the Principal to be used in the performance of the Contract under a contract which provides that all or any part of the rent is to be applied towards the purchase price thereof, shall only be a Claimant to the extent of the prevailing industrial rental value of such equipment for the period during which the equipment was used in the performance of the Contract. The prevailing industrial value of equipment shall be determined, insofar as it is practical to do so, in accordance with and in the manner provided for in the latest revised edition of the publication of the Canadian Construction Association titled "Rental Rates on Contractors Equipment" published before the period during which the equipment was used in the performance of the Contract.
2. The Principal and the Surety or Co-Sureties, as the case may be, hereby jointly and severally agree with the Obligee that every Claimant who has not been paid as provided for under the terms of their contract with the Principal, before the expiration of a period of ninety (90) days after the date on which the last of such Claimant's work or labour was done or performed or materials were furnished by such Claimant, may use the name of the Obligee to sue on and enforce the provisions of this bond, prosecute the suit to final judgment for such sum or sums as may be justly due to such Claimant under the terms of their contract with the Principal and have execution thereon subject to the following terms and conditions: the Obligee is not to be obliged to do or take any act, action or proceeding against the Surety or Co-Sureties on behalf of the Claimants, or any of them, to enforce the provisions of this Bond; and if any act, action or proceeding is taken either in the name of the Obligee or by joining the Obligee as a party to such proceeding, then such act, action or proceeding, shall be taken on the understanding and basis that the Claimants, or any of them, who take such act, action or proceeding shall indemnify and save harmless the Obligee against all costs, charges and expenses or liabilities incurred thereon and any loss or damage resulting to the Obligee by reason thereof.

3. No suit or action shall be commenced hereunder by any Claimant:
 - (a) unless such Claimant shall have given written notice within the time limits hereinafter set forth to each of the Principal, the Surety or Co-Sureties, as the case may be, and the Oblige, stating with substantial accuracy the amount claimed and at least 90 days shall have passed since the notice was given. Such notice shall be served by mailing the same by registered mail to the Principal, the Surety and the Oblige, at any place where an office is regularly maintained for the transaction of business by such persons or served in any manner in which legal process may be served in the Province or other part of Canada in which the subject matter of the contract is located. Such notice shall be given:
 - (i) in respect of any claim for the amount or any portion thereof, required to be held back from the Claimant by the Principal, under either the terms of the Claimant's contract with the Principal or under the builders lien Legislation applicable to the Claimant's contract with the Principal (whichever is the greater), within one hundred and twenty (120) days after such Claimant should have been paid in full under the Claimant's contract with the Principal.
 - (ii) in respect of any claim other than for the holdback, or portion thereof, referred to above, within one hundred and twenty (120) days after the date upon which such Claimant did, or performed, the last of the work or labour or furnished the last of the materials for which such claim is made, under the Claimant's contract with the Principal;
 - (b) after the expiration of one (1) year following the earlier of:
 - (i) the expiry of:
 - (A) the Contract Term; or
 - (B) the date on which the Principal ceased work on the Contract, including work performed under the guarantees provided in the Contract.
 - (c) other than in a Court of competent jurisdiction in a Province or Territory of Canada in which the subject matter of the Contract, or any part thereof, is situated and not elsewhere, and the parties hereto agree to submit to the jurisdiction of such Court.
4. The Surety or Co-Sureties, as the case may be, agree(s) not to take advantage of Article 2365 of the Civil Code of the Province of Quebec in the event that, by an act or an omission of a Claimant, the Surety can no longer be subrogated in the rights, hypothecs and privileges of said Claimant.
5. The amount of this Bond shall be reduced by, and to the extent of any payment or payments made in good faith, and in accordance with the provisions hereof, inclusive of the payment by the Surety or Co-Sureties, as the case may be, of builders liens which may be filed of record against the subject matter of the contract, whether or not claim for the amount of such lien be presented under and against this Bond.
6. The Surety or Co-Sureties, as the case may be, shall not be liable for a greater sum than the specified penalty of this Bond.
7. If this Bond is issued by Co-Sureties, then the Co-Surety that signs the first signature block on this Bond shall be designated as the "Lead Surety" for the purposes of this Bond and the Co-Sureties hereby jointly and severally irrevocably: appoint and authorize the Lead Surety to act as the sole representative of and agent for the Co-Sureties, and with authority to bind the Co-Sureties, in all dealings and matters between the Co-Sureties and the Oblige arising from or relating to this Bond, including without limitation the receipt on behalf of the Co-Sureties of a written notice, of any demand or draw on this Bond issued by the Oblige and in the investigation, payment, compromise, settlement and defence of any claims, demands and draws on, arising from or related to this Bond; and, agree and acknowledge that the Oblige shall be entitled to assume that any act done, document executed or entered into or waiver given by the Lead Surety to the Oblige arising from or related to this Bond has been duly authorized by each Co-Surety and is binding upon each Co-Surety without the Oblige being under any obligation to enquire into the authority of the Lead Surety in such matters.

8. The term of this Bond is for the Term of the Contract, as defined in the Contract, beginning at 12:01 am pacific time on September 1, 2021 and ending at 12:00 midnight pacific time on August 31, 2026.

IN WITNESS WHEREOF, the Principal and the Surety have Signed and Sealed this Bond
this _____ day of _____ 20__

SIGNED and SEALED

In the presence of:

For the Principal

SEAL

For the Surety Attorney-in-fact

SEAL

SPECIMEN SET - BONDS (continued)

PERFORMANCE BOND

NO.

\$1,230,000

KNOW ALL PERSONS BY THESE PRESENTS, that Contractor's Name as principal ("the Principal") and Surety / Insurance Company's or Companies' name(s) and address(es), a corporation or corporations created and existing under the laws of Canada, and duly authorized to transact the business of suretyship in Canada, as Surety (the "Surety" if one Surety is named in this Bond and the "Co-Sureties" if more than one), is/are held and firmly bound, jointly and severally in the case of Co-Sureties, unto HER MAJESTY THE QUEEN IN RIGHT OF THE PROVINCE OF BRITISH COLUMBIA AS REPRESENTED BY THE MINISTER RESPONSIBLE FOR THE TRANSPORTATION ACT, as obligee ("the Obligee") in the amount of One Million Two Hundred Thirty Thousand Dollars (\$1,230,000.00), of lawful money of Canada (the "Bond Amount"), for the payment of which sum, well and truly to be made, the Principal and the Surety, or Co-Sureties, as the case may be, bind themselves, their heirs, executors, administrators, successors and assigns, jointly and severally, firmly by these presents.

WHEREAS, the Principal has entered into a multi-year contract with the Obligee, dated the @ day of @ 20@@ for Electrical Maintenance Service Agreement Lower Mainland East Electrical Service Area (the "Contract") for a five (5) year term from September 1, 2021 (the "Commencement Date") to August 31, 2026 (the "Expiry Date") (the "Contract Term") that may be extended for a further five year period to August 31, 2031 all in accordance with its provisions (the "Contract Renewal Term"), and which document is incorporated by reference as part of this Bond;

AND WHEREAS concurrently with the issuance of this Performance Bond the Surety has issued a Labour and Material Payment Bond which names Her Majesty the Queen in Right of the Province of British Columbia as represented by the Minister Responsible for the Transportation Act, as Obligee (the "L&M Payment Bond").

NOW, THEREFORE, THE CONDITIONS OF THIS OBLIGATION are such that if the Principal shall promptly and faithfully perform that portion of the Contract that corresponds with the Contract Term or Contract Renewal Term (as those terms are defined herein), as the case may be, then this Obligation shall be null and void; otherwise it shall remain in full force and effect, subject, however, to the following conditions:

1. If the Obligee declares an Event of Default, as defined in the Contract, then upon written notice of same being given by the Obligee to the Surety or Co-Sureties as the case may be, the following shall apply:
 - (a) if the work is not taken out of the Principal's hands, by the Obligee, the Obligee may require the Surety or Co-Sureties, to remedy the default giving rise to the Event of Default, in which case the Surety or Co-Sureties shall cause the Principal to remedy the Event of Default within thirty (30) days of the date the Surety or Co-Sureties received the written notice from the Obligee or, if the Principal has not remedied the Event of Default, the Surety or Co-Sureties shall, subject to the Bond Amount, remedy the Event of Default within a further period of fifteen (15) days; and/or;
 - (b) the Obligee may, whether or not the Contract is terminated, and whether or not the Contract is taken out of the Principal's hands by the Obligee, take reasonable steps to cure the Event of Default itself or to cause the Event of Default to be cured by other persons, and then make demand under this Bond for indemnification by the Principal and Surety or Co-Sureties for the costs thereof after making all reasonable adjustments and credits under the Contract, in which case the resulting cost, including but not limited to the costs of the Event of Default and administrative costs of the Obligee, determined by the Obligee, shall be paid by the Principal within thirty (30) days of demand by the Obligee or, failing payment by the Principal, shall be paid, subject to paragraph 2 of this Bond, by the Surety or Co-Sureties within the following fifteen (15) day period; and/or
 - (c) the Obligee may take the Contract out of the Principal's hands, in which case:
 - (i) if after written notice has been given to the Surety or Co-Sureties of the Event of Default, the Surety or Co-Sureties and the Obligee agree in writing, the Surety or Co-Sureties may complete or cause to be completed the Contract, through methods including, but not limited to using the employees, equipment and subcontractors of the Principal;
 - (ii) absent such agreement,

- (1) the Obligee will request proposals for the completion of the Contract;
- (2) the Obligee will, with consultation from the Surety or Co-Sureties, if requested by the Surety or Co-Sureties, evaluate all proposals PROVIDED THAT the final selection of a replacement contractor shall be within the sole discretion of the Obligee, after consultation with the Surety or Co-Sureties.

If the Obligee considers the Event of Default to represent a material risk to public safety then the Obligee may take immediate steps to protect public safety by engaging others (the "Emergency Forces") to perform such services as the Obligee may reasonably decide are required for the purpose of ensuring services, works, safeguards, environmental protection and public safety are maintained and, further, to ensure that necessary work shall reasonably proceed with minimal interruption. The Obligee and the Surety will meet at the reasonable request of the Surety, to explore methods of completing the work under the Contract, including engaging a permanent replacement contractor pursuant to the provisions of Clause 1(c) of this Bond. The Emergency Forces may remain in place until a replacement contractor is appointed or until other arrangements for completing the work or the Contract, acceptable to the Obligee, are made by the Surety or Co-Sureties.

Upon selection by the Obligee of a bidder acceptable to the Obligee, the Obligee will contract with such bidder. The Surety or Co-Sureties will pay, at the direction of the Obligee, not less frequently than every thirty (30) days, as work progresses, whether by Emergency Forces or by a replacement contractor or both, sufficient funds to pay by monthly instalments the difference between the cost of completion of all the obligations of the Principal under the Contract and the balance of the Contract price; but not exceeding, including other costs and damages for which the Surety or Co-Sureties may be liable hereunder, the Bond Amount. The term "balance of the Contract price" as used in this Bond means the total amount payable by the Obligee to the Principal under the Contract, less the amount properly paid by the Obligee to the Principal.

2. Unless otherwise agreed in writing by the Surety or Co-Sureties and the Obligee, all payments under this Bond will be made on a monthly basis such that within thirty (30) days of the end of any month for which a claim is made under this Bond, the Surety or Co-Sureties will pay to or at the direction of the Obligee:

- (a) the difference between:
 - (i) the amount of the payment that would have been due from the Obligee to the Principal for that month pursuant to the Contract, but for the default of the Principal; and
 - (ii) the amount paid by the Obligee to other contractors to complete the obligations of the Principal under the contract for that month

- and -
- (b) the reasonable additional and actual direct costs incurred by the Obligee to select and retain the other contractors required to complete the work of the Principal and to direct the completion of the work for that month.

The cumulative total of the monthly payments will be subject to the final adjustment after the expiry of the original term of the Contract when all costs are known.

3. The requirement to make payment under this Bond will arise solely on the written demand for payment by the Obligee in respect of an Event of Default under the Contract or this Bond and the making of any payment under or pursuant to this Bond shall not be deemed to be an admission of liability on behalf of the Principal or Surety or Co-Sureties and will be made without prejudice to any right or cause of action which either or both the Principal or Surety or Co-Sureties may have against the Obligee. If payment has been made under or pursuant to the Bond by the Surety or if the Principal has paid to remedy the Event of Default or paid the cost of completion under the Contract, either the Principal or Surety or Co-Sureties may challenge the validity of the declaration of the Event of Default, the demand under this Bond, the accounting for Contract monies, the reasonableness or validity of the completion costs, or any other claim they may have relating to the Obligee's performance under the Contract and this Bond and make claim against the Obligee for damages.

4. Nothing herein contained shall release the Obligee from any duty to operate with the utmost good faith and to mitigate any costs or damages incurred as a result of the Event of Default. PROVIDED ALWAYS that the provision as to mitigation shall not be construed as requiring the Obligee to allow the Principal to complete the Contract.
5. Either or both the Principal or Surety or Co-Sureties may, by giving written notice to the Obligee within fourteen (14) days of receiving notice of an Event of Default from the Obligee, take the position that the notice of the Event of Default was wrongfully issued by the Obligee and claim for damages by suit, arbitration, or otherwise, provided however that neither delivery of such notice, nor any litigation, arbitration or other dispute resolution process, actual or contemplated, shall in any way delay payment from the Principal or failing payment by the Principal then from the Surety or Co-Sureties, and any payment will be made without prejudice to the right of the Principal or Surety or Co-Sureties to pursue any claim against the Obligee by litigation, arbitration or otherwise.
6. If a Court of competent jurisdiction, or an arbitrator in any arbitration proceeding between the Obligee and any one or more of the Principal and Surety or Co-Sureties, where the agreement to arbitrate provides that the decision is to be final and binding on the parties, holds that funds are owing by the Obligee to the Principal or Surety in connection with the Contract or Bond, the Obligee shall, after the period for appeals has expired, provided no appeals have been filed, remit the amount of any judgement or award to either the Principal or the Surety or Co-Sureties, with interest as determined in accordance with the provisions of B.C. Regulation 215/83 entitled "Interest on Overdue Accounts Payable Regulation", as amended from time to time from the date of such decision by the Court or arbitrator. Subject to the judgement or award, such payment obligation shall be without prejudice to any rights available to the Obligee.
7. The Obligee shall account for any unpaid Contract monies, including any holdback monies, relating to the Contract up to the date of the Event of Default as declared by the Obligee, which are payable to the Principal, and upon written notice from the Surety or Co-Sureties shall apply those monies:
 - (a) first, to pay for labour, material, equipment and services used by the Principal in the performance of the Contract prior to the Event of Default;
 - (b) second, to reimburse the Obligee for the difference between the cost of completion and the balance of the Contract price.

Any excess and all remaining Contract monies shall be paid by the Obligee to the Surety or Co-Sureties. Subject to the terms of this Bond and the Bond Amount, the Surety or Co-Sureties shall be liable for and pay the Obligee for the difference between the cost of completion under the Contract and the balance of the Contract price if the cost of completion exceeds the Contract price, and such other costs of completing the obligations of the Principal, including reasonable additional administrative costs of the Obligee, as determined by the Obligee, acting reasonably.

8. The Surety or Co-Sureties shall not be liable for any amount in excess of the Bond Amount. The Surety or Co-Sureties shall deliver to the Obligee timely notice of the amount from time to time paid under this Bond, and the Bond Amount shall be reduced by any amounts paid by the Surety or Co-Sureties to remedy or to cause to be remedied any Event of Default, notice of which has been provided by the Obligee to the Surety, with demand for payment, and by any amounts paid by the Surety under, or pursuant to its obligations under, this Bond.
9. The Obligee, whether or not an Event of Default has occurred or been declared, may advise the Surety or Co-Sureties in writing whenever:
 - (a) a Non-Conformance Report is issued by the Obligee to the Principal pursuant to Section 21.8 of the Contract;
 - (b) the Obligee issues written notice of an Event of Default to the Principal pursuant to Section 22.2 of the Contract; or
 - (c) the Obligee retains any holdback from any payment which, but for the holdback and the Obligee's reason for the holdback, would be due to the Principal under the Contract.

Copies of the Non-Conformance Report, notice of an Event of Default and notice of holdback may be provided to the Surety or Co-Sureties with the notice advising the Surety or Co-Sureties of same. Unless accompanied by a notice of a non-conformance or Event of Default and a written demand by the Obligee to the Surety or Co-Sureties requiring the Surety or Co-Sureties to fulfill

its obligations under the Bond, such advice and copies of such documents shall be considered to be for general information only and shall not constitute a declaration of an Event of Default nor a call upon this Bond.

10. No suit or action shall be instituted by the Obligees against the Surety, or by the Surety or Co-Sureties or the Principal against the Obligees, under or pursuant to this Bond, after the expiration of two years following the earlier of:
 - (a) the Expiry Date of the Contract Term; or
 - (b) the date on which the Principal ceased work on the Contract during the Contract Term, including work performed under any guarantees provided in the Contract.
11. If this Bond is issued by Co-Sureties, then the Co-Surety that signs the first signature block on this Bond shall be designated as the "Lead Surety" for the purposes of this Bond and the Co-Sureties hereby jointly and severally irrevocably: appoint and authorize the Lead Surety to act as the sole representative of and agent for the Co-Sureties, and with authority to bind the Co-Sureties, in all dealings and matters between the Co-Sureties and the Obligees arising from or relating to this Bond, including without limitation the receipt on behalf of the Co-Sureties of a written notice, of any demand or draw on this Bond issued by the Obligees and in the investigation, payment, compromise, settlement and defence of any claims, demands and draws on, arising from or related to this Bond; and, agree and acknowledge that the Obligees shall be entitled to assume that any act done, document executed or entered into or waiver given by the Lead Surety to the Obligees arising from or related to this Bond has been duly authorized by each Co-Surety and is binding upon each Co-Surety without the Obligees being under any obligation to enquire into the authority of the Lead Surety in such matters.
12. The term of this Bond is for the Contract Term of the Contract, beginning at 12:01 am pacific time on September 1, 2021, and ending at 12:00 midnight pacific time on August 31, 2026.
13. All notices and demands to be given to the Surety under this Bond shall be given to the Surety at the following address:

(Name and Address of Surety)

Attention: _____

IN WITNESS WHEREOF, the Principal and the Surety have Signed and Sealed this bond this ____ day of _____, 20 ____.

SIGNED and SEALED

In the presence of:

For the Principal

SEAL

For the Surety

Attorney-in-fact

SEAL

**LABOUR AND MATERIAL PAYMENT BOND
EXTENSION AND AMENDMENT AGREEMENT NO. @@
ELECTRICAL MAINTENANCE SERVICES AGREEMENT
@@ Electrical Service Area**

THIS AGREEMENT dated for reference the ____ day of @@, 20@ (the "Reference Date").

BETWEEN

@@ [the Surety's name here or Co-Sureties if more than one], a company or companies authorized to carry on business in the Province of British Columbia (the "Surety" if one surety is named in this Bond or "Co-Sureties" if more than one)

AND

HER MAJESTY THE QUEEN IN RIGHT OF THE PROVINCE OF BRITISH COLUMBIA, as represented by the Minister Responsible for the Transportation Act (the "Obligee")

AND

@@ [the contractor's name here], having its registered office at @@ (the "Principal")

WHEREAS:

- A. The Surety or Co-Sureties, as the case may be, issued a Labour and Material Payment Bond No. @@ ("L&M Bond") simultaneously with a Performance Bond No. @@, dated the @@ day of @@, 20@@, [delete if inapplicable: as extended to the @@ day of @@, 20@@ by Extension and Amendment Agreement No. 1 dated the @@ day of @@, 20@@], in connection with the Electrical Maintenance Services Agreement between the Principal and the Obligee for the @@ Electrical Service Area with a commencement date of the @@ day of @@, 20@@, and as extended by notice in accordance with its terms from the @@ day of @@, 20@@ to the @@ day of @@, 20@@ (the "Contract Renewal Term") (together, the "Contract");
- B. Pursuant to the Contract, the Principal is obligated to maintain the L&M Bond in full force and effect during the Term;
- C. The Surety or Co-Sureties, as the case may be, elects to extend the L&M Bond for the five (5) years of the Contract Renewal Term and the Principal wishes to deliver to the Obligee, or cause the Surety or Co-Sureties, as the case may be, to deliver to the Obligee, the unconditional written agreement of the Surety or Co-Sureties, as the case may be, to extend and maintain the L&M Bond in full force and effect for the Contract Renewal Term;
- D. The Surety or Co-Sureties, as the case may be, the Principal and the Obligee wish to amend the terms of the L&M Bond in accordance with the terms of this Agreement.

NOW THEREFORE in consideration of the payment of \$1.00 by the parties, each to the others, the receipt and sufficiency of which is hereby acknowledged by each party, the Surety or Co-Sureties, as the case may be, the Principal and the Obligee agree, and in the case of the Surety or Co-Sureties, as the case may be, and the Principal, the Surety or Co-Sureties, as the case may be, and the Principal jointly and severally agree as follows:

- 1. Unless otherwise expressly defined in this Agreement, the capitalized words in this Agreement have the meanings given to them in the Contract or in the L&M Bond, as the case may be.
- 2. This L&M Bond is extended to include the obligations on the part of the Principal to be observed and performed in connection with the Contract from and after 12:01 a.m. pacific time on @@ [insert the former expiry date/current

renewal date here], 20@@ to and including 12:00 midnight pacific time on @@[insert the extended expiry date here], 20@@.

- 3. No suit or action will be instituted by the Obligee against the Surety or Co-Sureties, as the case may be, or by the Surety or Co-Sureties, as the case may be, or the Principal against the Obligee, under or pursuant to this L&M Bond, after the expiration of one (1) year from the date on which the Principal ceased work on the Contract, including work performed under any guarantees provided in the Contract as represented by the Minister of Transportation and Infrastructure.
- 4. Nothing in this Agreement will limit or reduce the liability of the Surety or Co-Sureties, as the case may be, with respect to the obligations on the part of the Principal to be observed and performed to and including 12:01 a.m. pacific time on @@ [insert former expiry date/ current renewal date here], 20@@ in connection with the first @@ years of the Contract.
- 5. The terms of the L&M Bond:
 - (a) as ratified, confirmed, amended and extended herein, remain in full force and effect as of the Reference Date of this Agreement; and
 - (b) will be deemed to be continuous as extended.
- 6. Time is of the essence of this Agreement and will remain of the essence of the L&M Bond, as extended and amended by this Agreement.
- 7. Notwithstanding the date of execution or delivery of this Agreement, the terms of this Agreement will be effective from the Reference Date of this Agreement.

IN WITNESS WHEREOF the parties hereto have signed and sealed this Agreement by their duly authorized representatives and officers as follows:

@@

(c/s)

Authorized Signatory for the Surety/Co-Sureties

DATE

@@

(c/s)

Authorized Signatory for the Principal

DATE

**HER MAJESTY THE QUEEN IN RIGHT OF THE
PROVINCE OF BRITISH COLUMBIA as represented
by the Minister Responsible for the Transportation Act**

Authorized Signatory for the Obligee

DATE

PERFORMANCE BOND
EXTENSION AND AMENDMENT AGREEMENT No. @@1
ELECTRICAL MAINTENANCE SERVICES AGREEMENT
@@ Electrical Service Area

THIS AGREEMENT dated for reference the _____ day of _____, 20____ (the "Reference Date")

BETWEEN

@@ [the Surety's name here or Co-Sureties if more than one], a company or companies authorized to carry on business in the Province of British Columbia (the "Surety" if one surety is named in this Bond or "Co-Sureties" if more than one)

AND

HER MAJESTY THE QUEEN IN RIGHT OF THE PROVINCE OF BRITISH COLUMBIA, as represented by the Minister Responsible for the Transportation Act (the "Obligee")

AND

@@ [the contractor's name here], having its registered office at @@ (the "Principal")

WHEREAS:

- A. The Surety or Co-Sureties, as the case may be, issued a Performance Bond No. @@ ("Performance Bond") simultaneously with a Labour and Material Payment Bond dated the @@ day of @@, 20@@ ("L&M Bond"), [*delete if inapplicable*: as extended to the @@ day of @@, 20@@ by Extension and Amendment Agreement No. 1 dated the @@ day of @@, 20@@] in connection with the Electrical Maintenance Services Agreement between the Principal and the Obligee for the @@ Electrical Service Area with a commencement date of the @@ day of @@, 20@@ and as that contract is extended by notice in accordance with its terms from the @@ day of @@, 20@@ to the @@ day of @@, 20@@ (the "Contract Renewal Term") (together, the "Contract");
- B. Pursuant to the Contract, the Principal is obligated to maintain the Performance Bond in full force and effect during the Term;
- C. The Surety or Co-Sureties, as the case may be, elects to extend the Performance Bond for the five (5) years of the Contract Renewal Term and the Principal wishes to deliver to the Obligee, or cause the Surety or Co-Sureties, as the case may be, to deliver to the Obligee, the unconditional written agreement of the Surety or Co-Sureties, as the case may be, to extend and maintain the Performance Bond in full force and effect for the Contract Renewal Term;
- D. The Surety or Co-Sureties, as the case may be, the Principal and the Obligee wish to amend the terms of the Performance Bond in accordance with the terms of this Agreement.

NOW THEREFORE in consideration of the payment of \$1.00 by the parties, each to the others, the receipt and sufficiency of which is hereby acknowledged by each party, the Surety or Co-Sureties, as the case may be, the Principal and the Obligee agree, and in the case of the Surety and the Principal, the Surety or Co-Sureties, as the case may be, and the Principal jointly

¹ Additional paragraphs are required if the bond extension is not for the entire @@ years to the end of the contract term.
ELECTRICAL MAINTENANCE SERVICE AGREEMENT – SCHEDULE 14 – BONDS

and severally agree as follows:

1. Unless otherwise expressly defined in this Agreement, the capitalized words in this Agreement have the meanings given to them in the Contract or in the Performance Bond, as the case may be.
2. The Performance Bond is extended to include the obligations on the part of the Principal to be observed and performed in connection with the Contract from and after 12:01 a.m. pacific time on @@[insert the former expiry date here] to and including 12:00 midnight pacific time on @@[insert the new expiry date here] in connection with the Contract.
3. Nothing in this Agreement will limit or reduce the liability of the Surety or Co-Sureties, as the case may be, with respect to the obligations on the part of the Principal to be observed and performed to and including 12:01 a.m. pacific time on @@ in connection with the first @@ years of the Contract.
4. The terms of the Performance Bond:
 - (a) as ratified, confirmed, amended and extended herein, remain in full force and effect as of the Reference Date of this Agreement; and
 - (b) will be deemed to be continuous as extended.
5. Time is of the essence of this Agreement and will remain of the essence of the Performance Bond, as extended and amended by this Agreement.
6. Notwithstanding the date of execution or delivery of this Agreement, the terms of this Agreement will be effective from the Reference Date of this Agreement.

IN WITNESS WHEREOF the parties hereto have signed and sealed this Agreement by their duly authorized representatives and officers as follows:

@@

(c/s)

Authorized Signatory for the Surety/Co-Sureties

DATE

@@

(c/s)

Authorized Signatory for the Principal

DATE

**HER MAJESTY THE QUEEN IN RIGHT OF
THE PROVINCE OF BRITISH COLUMBIA as
represented by the Minister Responsible for the
Transportation Act**

Authorized Signatory for the Obligee

DATE

SCHEDULE 15 – INSURANCE

1. ISSUANCE OF INSURANCE

All insurance coverage will be issued with insurers acceptable to the Province, and issued by companies licensed to transact business in the Province of British Columbia.

2. EVIDENCE OF COVERAGE

The following evidence of coverage will be supplied by the Contractor not later than the 30th day prior to the Commencement Date:

File originals or signed, certified copies of all current policies and any other endorsements necessary to comply with these insurance specifications and any other requirements outlined in the Agreement, to:

The Corporate Insurance and Bonds Manager,
Ministry of Transportation and Infrastructure,
PO Box 9850 STN Prov Govt,
4th Floor, 940 Blanshard Street,
Victoria, B.C. V8W 9T5.

Any endorsements issued to satisfy the specific requirements outlined in these documents must be countersigned, and only original or certified copies of endorsements are acceptable.

For Automobile Liability insurance, a duly executed Insurance Corporation of British Columbia APV250L or APV 47 form may be used for evidence of coverage or renewal provided that, if excess limits are purchased through private insurers, evidence will be provided by way of signed, certified copies of these policies.

As an INTERIM measure the Contractor may provide certification that the insurance requirements have been met, by way of a duly completed Ministry Certificate of Insurance (H0111), subject to the condition that originals or signed, certified copies of all current policies and necessary endorsements shall be forwarded within sixty (60) days of the date of issuance of this Certificate to: The Corporate Insurance and Bonds Manager, Ministry of Transportation and Infrastructure, PO Box 9850 STN Prov Govt, 4th Floor, 940 Blanshard Street, Victoria, B.C. V8W 9T5.

NO OTHER CERTIFICATES OF INSURANCE ARE ACCEPTABLE

Payments to the Contractor may be withheld and/or all work on the site of the Agreement may be ordered to cease if the Contractor fails to obtain or maintain insurance as required herein, or if the Ministry does not approve any insurance policy or policies submitted to them and the Contractor does not comply with the insurance requirements of the Agreement and, the Ministry shall also have the right, but not the obligation, to place and maintain such insurance in the name of the Contractor and the Ministry. The cost thereof shall be payable by the Contractor to the Ministry on demand, and the Ministry may deduct the cost thereof from any monies which are due, or may become due to the Contractor.

3. LIABILITY POLICIES

THIRD PARTY LIABILITY INSURANCE

Commercial General Liability insurance including non-owned automobile and contractual liability insurance will be arranged with inclusive limits of not less than TEN MILLION DOLLARS (\$10,000,000.00) for bodily injury, death, and property damage arising from any one accident or occurrence. The insurance policy will pay on behalf of the named insureds, additional named insureds and the additional insureds under the policy for any sum or sums which the insured may become liable to pay or shall pay for bodily injury, death or property damage or for loss of use thereof, arising out of or resulting from the work or operations of the Contractor or subcontractors, including all persons, firms

or corporations who perform any of the work, in connection with the Agreement, anywhere within Canada and the United States of America. In addition to the above limits, such liability insurance will also pay all costs, charges, and expenses in connection with any claims that may require to be contested by the insureds anywhere within Canada and the United States of America.

EXTENSION OF COVERAGE

Such liability insurance will cover liability assumed by the Contractor in connection with and applicable to the Agreement and will include the following coverage extensions applicable to the following liability policies:

Coverage Extensions Applicable to the Commercial General Liability Policy

- * Canada and United States coverage territory
- * Products/Completed Operations
- * Occurrence Property Damage
- * Broad Form Property Damage
- * Contingent Employers Liability
- * Medical Payments
- * Incidental Medical Malpractice
- * Blanket Written Contractual
- * Cross Liability
- * Attached Machinery
- * Non Owned Automobile
- * Legal Liability for damage to hired automobiles
- * Hazardous Operations (XCU)
- * Sudden and Accidental Pollution with coverage of not less than \$5,000,000.00 (IBC Form #2313)
- * 30 days notice of Cancellation or Limitation of cover (as more fully outlined under Section 6 of this Schedule)

INCLUSIONS/EXCLUSIONS NOT PERMITTED

Hazardous operations, including excavation pile driving, shoring, blasting, underpinning, or demolition work or any other operation or work to be performed will not be excluded from insurance coverage.

Claims arising out of the legal liability imposed upon the insured at common law and extended by Statute for bodily injury or death to employees of the insured will not be excluded. However, exclusions applicable to liability imposed upon or assumed by the insured under any Workers' Compensation Statute or for assessments by any Workers' Compensation Board will be permitted.

Liability assumed by the insured under contract with railroad companies for the use and operation of railway sidings or crossings will not be excluded.

Liability arising out of all products where the Contractor supplies the material will not be excluded.

Tort liability assumed by the Contractor under the Agreement will not be excluded.

Exclusion of joint venture projects will not be permitted.

Other types of services not listed above, to be performed by the Contractor under the Agreement will not be excluded.

If vessels owned, leased or operated in the course of the Agreement are covered under the Commercial General Liability policy for all bodily injury or death and property damage, then the Contractor will ensure that at all times during the term of the Agreement the minimum limits and amounts as required by the Marine Liability Act and/or regulations to the Marine Liability Act are maintained. The Contractor will be responsible for ensuring that any changes to the requirements of the Marine Liability Act and/or the regulations of the Marine Liability Act are reflected in the

insurance coverage provided. Notwithstanding the requirements of the Marine Liability Act, the limits under the Commercial General Liability insurance must not be less than **\$10,000,000 (TEN MILLION)**.

DEDUCTIBLE

A **maximum** deductible on the primary insurance policy will be allowed for any one accident or per occurrence for up to **FIFTY THOUSAND DOLLARS (\$50,000.00)** Payment of any deductible will be the responsibility of the Contractor.

SELF-INSURED RETENTION

A **maximum** self-insured retention of up to **FIFTY THOUSAND DOLLARS (\$50,000.00)** for any one accident or per occurrence will be permitted for Contractors providing umbrella/excess liability insurance subject to having a **minimum** primary insurance policy of **TWO MILLION DOLLARS (\$2,000,000.00)** underlying the umbrella/excess.

PROTECTION AND INDEMNITY INSURANCE

IF vessels are owned, leased or operated in the course of the Agreement by the Contractor, and are not covered under the Commercial General Liability policy, then the Contractor will provide Protection and Indemnity insurance for all bodily injury or death and property damage with limits of not less than **TEN MILLION DOLLARS (\$10,000,000.00)** for such vessels. Such Protection and Indemnity insurance will include four-fourths collision liability insurance. The Contractor will be responsible for ensuring that any changes to the requirements of the Marine Liability Act and/or the regulations of the Marine Liability Act are reflected in the insurance coverage provided. Notwithstanding the requirements of the Marine Liability Act, the limits under the Commercial General Liability insurance must not be less than **\$10,000,000 (TEN MILLION)**.

AERIAL TRAMS AND/OR FERRIES

IF aerial trams or ferries operated in the course of the Agreement are not covered under the Commercial General Liability policy, then the Contractor will obtain and maintain insurance applying to all aerial trams or ferries operated in the course of the Agreement. The Contractor shall ensure that at all times during the term of the Agreement the minimum limits and amounts of not less than **TEN MILLION DOLLARS (\$10,000,000.00)** are maintained.

AUTOMOBILE INSURANCE

Automobile Liability coverage with inclusive limits of not less than **TEN MILLION DOLLARS (\$5,000,000.00)** providing third party liability and accident benefits insurance and automobile physical damage insurance including collision and comprehensive coverage must be provided for all vehicles required by law to be licensed that are owned, leased or rented by the Contractor, and that are used in the performance of the Agreement.

AIRCRAFT INSURANCE

IF aircraft (including helicopters) are used in the performance of the Agreement and are owned, leased or rented by the Contractor, then third party liability coverage with inclusive limits of not less than **TEN MILLION DOLLARS (\$10,000,000.00)** must be provided.

UNMANNED AERIAL VEHICLES

IF unmanned aerial vehicle systems are used in the performance of this Agreement and are owned, leased or rented by the Contractor, then third party liability coverage, in accordance with the requirements of Transport Canada _ Canadian Aviation Regulations (CARs) but for inclusive limits of not less than **FIVE MILLION DOLLARS (\$5,000,000.00)** must be provided.

4. **ADDITIONAL CONDITIONS FOR ALL LIABILITY POLICIES (except Owned Automobile Liability Insurance)**

Contractual Liability - the insurance provision set out above is the minimum coverage required by the Province under the Agreement.

Each Liability Policy will (except Owned Automobile Liability Insurance) be endorsed as follows:

"Notwithstanding any other terms, conditions, or exclusions elsewhere in this policy, it is understood and agreed that this policy is extended to include insurance coverages and clauses as follows:

Her Majesty the Queen in Right of the Province of British Columbia as represented by the Minister Responsible for the Transportation Act, together with the employees, agents, and servants of the Minister, hereinafter referred to as the Additional Named Insured, is added as an Additional Named Insured, in respect of liability arising from the work or operations of the Insured and the Additional Named Insured, in any way relating to maintenance of Highways within the Electrical Service Area including under the Agreement. .

The unqualified word "insured" also includes Contractors and subcontractors including all persons, firms or corporations who perform any part of the work under this Agreement.

The insurance as is afforded by this policy shall apply in the same manner and to the same extent as though a separate policy had been issued to each insured. Any breach of a condition of the policy by any Insured shall not affect the protection given by this policy to any other insured. The inclusion herein of more than one Insured shall not operate to increase the limit of liability under this policy.

Hazardous operations such as excavation, pile driving, shoring, blasting, underpinning, or demolition work or any other operation or work to be performed by the Province, Contractor or subcontractors, including all persons, firms or corporations who perform any of the work in connection with the Agreement, will not be excluded from insurance coverage, where such type of work or operation is to be performed by any such party under the Agreement subject to prior notification to the insurer by the Contractor."

5. **PROPERTY POLICIES**

EQUIPMENT INSURANCE

The Contractor will obtain, maintain and provide evidence of "ALL-RISKS" insurance coverage, satisfactory to the Province, covering all equipment utilized in the performance of the services under the Agreement that is owned, rented, or leased by the Contractor, or for which the Contractor may be responsible.

Policies must include the following Waiver of Subrogation:

"In the event of any third party loss or damage or any physical loss or damage to the work, or Contractor's equipment, the settlement or payment of the subsequent claim shall be made without the right of subrogation against her Majesty the Queen as represented by the Minister Responsible for the Transportation Act or any employees, servants or agents of the Minister."

6. ADDITIONAL REQUIREMENTS FOR ALL POLICIES

NOTICE OF CANCELLATION, ETC.

The required insurance will not be cancelled, removed, reduced, materially changed or altered except upon written consent of the Province, and in this connection thirty (30) days prior notice in writing must be given by Registered Mail to: The Manager, Corporate Insurance and Bonds, Ministry of Transportation and Infrastructure, PO Box 9850 STN Prov Govt, 4th Floor, 940 Blanshard Street, Victoria, B.C. V8W 9T5.

PRIMARY INSURANCE

All the foregoing insurance will be primary and not require the sharing of any loss by any other insurer of the Province.

EVIDENCE OF RENEWAL

The Contractor will furnish evidence of the renewal or extension the required policy(s) at least thirty (30) days prior to the expiry date of the policy by way of a duly completed Ministry Certificate of Insurance (H0111), subject to the condition that originals or signed, certified copies of all current policies and necessary endorsements shall be forwarded within one hundred and twenty (120) days of the date of issuance of the Ministry Certificate of Insurance to: **The Manager, Corporate Insurance and Bonds, Ministry of Transportation PO Box 9850 STN Prov Govt, 4th Floor, 940 Blanshard Street, Victoria, B.C. V8W 9T5.**

THE PROVINCE ASSUMES NO RESPONSIBILITY FOR THE ADEQUACY OF THE INSURANCE EFFECTED IN FAVOUR OF THE CONTRACTOR OR THE PROVINCE UNDER THE ELECTRICAL MAINTENANCE SERVICE AGREEMENT.

SCHEDULE 16 – INSURANCE & SECURITIES (RENEWAL TERM)

Consent of Surety (Renewal Term)

CONSENT OF SURETY

DATE:

NO:

WHEREAS _____ [Name of Contractor] as Principal entered into the contract dated for reference the ____ day of _____, 20____ (herein, the "Agreement") and entitled the ELECTRICAL MAINTENANCE SERVICE AGREEMENT LOWER MAINLAND EAST ELECTRICAL SERVICE AREA (the "Agreement"), with HER MAJESTY THE QUEEN IN RIGHT OF THE PROVINCE OF BRITISH COLUMBIA AS REPRESENTED BY THE MINISTER RESPONSIBLE FOR THE TRANSPORTATION ACT as Obligee, we, (Name of Surety or Co-Sureties), a corporation or corporations created and existing under the laws of Canada and duly authorized to transact the business of Suretyship in Canada, agree to issue as Surety or Co-Sureties, as the case may be, for the Principal the following bond(s) with respect to the Principal's obligations under the Contract:

1. A performance bond in the amount of \$@@ for the renewal term of 5 Contract Years containing terms and conditions matching those of the specimen performance bond in Schedule 14 ("Bonds") of the Agreement.
2. A labour and material payment bond in the amount of \$@@ for the renewal term of 5 Contract Years and containing terms and conditions matching those of the specimen labour and material payment bond in Schedule 14 ("Bonds") of the Agreement.

This consent must be null and void unless an application for the said bond(s) is made by not later than [date: last day of the second month before expiry of Term].

(Authorized Signatory for the Surety/Co-Sureties)

(Seal)

xxxxxx
Attorney - In - Fact

**UNDERTAKING TO PROVIDE LIABILITY INSURANCE
(FOR RENEWAL TERM)**

THIS UNDERTAKING dated as of [month/day/year] (the "Effective Date").

[Note 1. The total amount of the commercial general liability insurance coverage provided in this Undertaking must be the minimum stipulated by the Province but can be provided in more than one Undertaking via a combination of CGL/Excess/Umbrella coverage and by more than one insurer.]

To:

Her Majesty the Queen in Right of the Province of British Columbia as represented by the Minister Responsible for the Transportation Act (the "Province")
Ministry of Transportation and Infrastructure
Rehabilitation and Maintenance Branch
4C - 940 Blanshard Street
PO Box 9850 Stn Prov Govt
Victoria, BC V8W 9T5

Undertaking to Provide Liability Insurance

WHEREAS an Electrical Maintenance Services Agreement (the "Agreement") presently exists between the Province and _____ [Name of Contractor] for an initial term of five (5) years , which the Province and _____ [Name of Contractor] intend to renew for a further term of an additional five (5) years (the "Renewal Term").

We, the undersigned, as authorized representatives on behalf of _____ (NAME OF INSURANCE COMPANY) _____ do hereby undertake and agree to provide Commercial General Liability insurance in the amount of _____ DOLLARS (\$_____) for the Renewal Term of the Electrical Maintenance Services Agreement. This insurance will provide coverage, terms and conditions that comply with the insurance articles and requirements as described in the Agreement apart from the amount of said insurance complying with any change to same for the Renewal Term which may have been stipulated by the Province.

We further undertake and agree to provide to the Province signed, certified copies of such policies and attached endorsements no later than thirty (30) days before the commencement date of the Renewal Term of the Electrical Maintenance Services Agreement.

THIS UNDERTAKING will remain in full force and effect, for a period of not less than thirty days from the Effective Date, until and including [month/day/year] (the "Undertaking Expiry Date").

Dated at: _____
this ____ day of _____, 20__.

Signed: _____
Duly Authorized Representative of Insurance Company

SCHEDULE 17 - PRIVACY PROTECTION SCHEDULE

Definitions

1. In this Schedule,
 - (a) "access" means disclosure by the provision of access;
 - (b) "Act" means the *Freedom of Information and Protection of Privacy Act*;
 - (c) "contact information" means information to enable an individual at a place of business to be contacted and includes the name, position name or title, business telephone number, business address, business email or business fax number of the individual;
 - (d) "personal information" means recorded information about an identifiable individual, other than contact information, collected or created by the Contractor as a result of the Agreement or any previous agreement between the Province and the Contractor dealing with the same subject matter as the Agreement but excluding any such information that, if this Schedule did not apply to it, would not be under the "control of a public body" within the meaning of the Act; and
 - (e) "privacy course" means the Province's online privacy and information sharing training course.

Purpose

2. The purpose of this Schedule is to:
 - (a) enable the Province to comply with the Province's statutory obligations under the Act with respect to personal information; and
 - (b) ensure that, as a service provider, the Contractor is aware of and complies with the Contractor's statutory obligations under the Act with respect to personal information.

Collection of personal information

3. Unless the Agreement otherwise specifies or the Province otherwise directs in writing, the Contractor may only collect or create personal information that is necessary for the performance of the Contractor's obligations, or the exercise of the Contractor's rights, under the Agreement.
4. Unless the Agreement otherwise specifies or the Province otherwise directs in writing, the Contractor must collect personal information directly from the individual the information is about.
5. Unless the Agreement otherwise specifies or the Province otherwise directs in writing, the Contractor must tell an individual from whom the Contractor collects personal information:
 - (a) the purpose for collecting it;
 - (b) the legal authority for collecting it; and
 - (c) the title, business address and business telephone number of the person designated by the Province to answer questions about the Contractor's collection of personal information.

Privacy Training

6. The Contractor must ensure that each person who will provide services under the Agreement that involve the collection or creation of personal information will complete, at the Contractor's expense, the privacy course prior to that person providing those services.
7. The requirement in section 6 will only apply to persons who have not previously completed the privacy course.

Accuracy of personal information

8. The Contractor must make every reasonable effort to ensure the accuracy and completeness of any personal information to be used by the Contractor or the Province to make a decision that directly affects the individual the information is about.

Requests for access to personal information

9. If the Contractor receives a request for access to personal information from a person other than the Province, the Contractor must promptly advise the person to make the request to the Province unless the Agreement expressly requires the Contractor to provide such access and, if the Province has advised the Contractor of the name or title and contact information of an official of the Province to whom such requests are to be made, the Contractor must also promptly provide that official's name or title and contact information to the person making the request.

Correction of personal information

10. Within 5 Working Days of receiving a written direction from the Province to correct or annotate any personal information, the Contractor must annotate or correct the information in accordance with the direction.
11. When issuing a written direction under section 10, the Province must advise the Contractor of the date the correction request to which the direction relates was received by the Province in order that the Contractor may comply with section 12.
12. Within 5 Working Days of correcting or annotating any personal information under section 10, the Contractor must provide the corrected or annotated information to any party to whom, within one year prior to the date the correction request was made to the Province, the Contractor disclosed the information being corrected or annotated.
13. If the Contractor receives a request for correction of personal information from a person other than the Province, the Contractor must promptly advise the person to make the request to the Province and, if the Province has advised the Contractor of the name or title and contact information of an official of the Province to whom such requests are to be made, the Contractor must also promptly provide that official's name or title and contact information to the person making the request.

Protection of personal information

14. The Contractor must protect personal information by making reasonable security arrangements against such risks as unauthorized access, collection, use, disclosure or disposal, including any expressly set out in the Agreement.

Storage and access to personal information

15. Unless the Province otherwise directs in writing, the Contractor must not store personal information outside Canada or permit access to personal information from outside Canada.

Retention of personal information

16. Unless the Agreement otherwise specifies, the Contractor must retain personal information until directed by the Province in writing to dispose of it or deliver it as specified in the direction.

Use of personal information

17. Unless the Province otherwise directs in writing, the Contractor may only use personal information if that use is for the performance of the Contractor's obligations, or the exercise of the Contractor's rights, under the Agreement.

Disclosure of personal information

18. Unless the Province otherwise directs in writing, the Contractor may only disclose personal information inside Canada to any person other than the Province if the disclosure is for the performance of the Contractor's obligations, or the exercise of the Contractor's rights, under the Agreement.
19. Unless the Agreement otherwise specifies or the Province otherwise directs in writing, the Contractor must not disclose personal information outside Canada.

Notice of foreign demands for disclosure

20. In addition to any obligation the Contractor may have to provide the notification contemplated by section 30.2 of the Act, if in relation to personal information in the custody or under the control of the Contractor, the Contractor:
 - (a) receives a foreign demand for disclosure;
 - (b) receives a request to disclose, produce or provide access that the Contractor knows or has reason to suspect is for the purpose of responding to a foreign demand for disclosure; or
 - (c) has reason to suspect that an unauthorized disclosure of personal information has occurred in response to a foreign demand for disclosure

the Contractor must immediately notify the Province and, in so doing, provide the information described in section 30.2(3) of the Act. In this section, the phrases "foreign demand for disclosure" and "unauthorized disclosure of personal information" will bear the same meanings as in section 30.2 of the Act.

Notice of unauthorized disclosure

21. In addition to any obligation the Contractor may have to provide the notification contemplated by section 30.5 of the Act, if the Contractor knows that there has been an unauthorized disclosure of personal information in the custody or under the control of the Contractor, the Contractor must immediately notify the Province. In this section, the phrase "unauthorized disclosure of personal information" will bear the same meaning as in section 30.5 of the Act.

Inspection of personal information

22. In addition to any other rights of inspection the Province may have under the Agreement or under statute, the Province may, at any reasonable time and on reasonable notice to the Contractor, enter on the Contractor's premises to inspect any personal information in the possession of the Contractor or any of the Contractor's information management policies or practices relevant to the Contractor's management of personal information or the Contractor's compliance with this Schedule and the Contractor must permit, and provide reasonable assistance to, any such inspection.

Compliance with the Act and directions

23. The Contractor must in relation to personal information comply with:
 - (a) the requirements of the Act applicable to the Contractor as a service provider, including any applicable order of the commissioner under the Act; and
 - (b) any direction given by the Province under this Schedule.
24. The Contractor acknowledges that it is familiar with the requirements of the Act governing personal information that are applicable to it as a service provider.

Notice of non-compliance

25. If for any reason the Contractor does not comply, or anticipates that it will be unable to comply, with a provision in this Schedule in any respect, the Contractor must promptly notify the Province of the particulars of the non-compliance or anticipated non-compliance and what steps it proposes to take to address, or prevent recurrence of, the non-compliance or anticipated non-compliance.

Termination of Agreement

26. In addition to any other rights of termination which the Province may have under the Agreement or otherwise at law, the Province may, subject to any provisions in the Agreement establishing mandatory cure periods for defaults by the Contractor, terminate the Agreement by giving written notice of such termination to the Contractor, upon any failure of the Contractor to comply with this Schedule in a material respect.

Interpretation

27. In this Schedule, references to sections by number are to sections of this Schedule unless otherwise specified in this Schedule.
28. Any reference to the "Contractor" in this Schedule includes any subcontractor or agent retained by the Contractor to perform obligations under the Agreement and the Contractor must ensure that any such subcontractors and agents comply with this Schedule.
29. The obligations of the Contractor in this Schedule will survive the termination of the Agreement.
30. If a provision of the Agreement (including any direction given by the Province under this Schedule) conflicts with a requirement of the Act or an applicable order of the commissioner under the Act, the conflicting provision of the Agreement (or direction) will be inoperative to the extent of the conflict.
31. The Contractor must comply with the provisions of this Schedule despite any conflicting provision of this Agreement or, subject to section 32, the law of any jurisdiction outside Canada.
32. Nothing in this Schedule requires the Contractor to contravene the law of any jurisdiction outside Canada unless such contravention is required to comply with the Act.

SCHEDULE 18 – CONTRACTOR DETAILS

Complete Corporate or Partnership Name: _____

Jurisdiction of Incorporation or Registration: _____

Incorporation or Registration No.: _____

Date of Incorporation or formation of Partnership: _____

Directors
Name

Address

Officers
Name

Office Held

Authorized Share Capital:

Special Rights applicable to each class of authorized share capital:

Voting Agreements:

Encumbrances:

Transactions in the last six (6) months involving the disposition of all or substantially all of the Contractor's Assets:

Shareholders/Partners/Joint
Venture Members

Name

Address

No. and % of Shares/Partnership
Interest/Joint Venture Interest Held
Legally and/or Beneficially

*if any of the partners or joint venture members are corporate entities then a separate Schedule 18 ("Contractor Details") ("Contractor Details") for each corporate partner or joint venture member must be completed and delivered in accordance with Article 2 of this Agreement.

SCHEDULE 19 – TAX VERIFICATION

- i) In this Schedule:
 - a) “Tax Verification Letter” means a letter issued by the Province of British Columbia’s Ministry of Finance verifying that the Contractor meets its applicable B.C. corporate income tax filing obligations and provincial sales tax (PST) filing and payment obligations; and
 - b) “Valid” means that the Tax Verification Letter’s period of validity, as indicated on the Tax Verification Letter, has not ended.
- ii) As a condition of entering into this Agreement, the Contractor provided to the Province a Valid Tax Verification Letter.
- iii) Upon request by the Province, the Contractor must provide the Province with a new Valid Tax Verification Letter. Notwithstanding any other provision of this Agreement, the Contractor acknowledges and agrees that any extension or renewal of this Agreement is conditional upon the Province having, or receiving from the Contractor in response to a request from the Province, a Valid Tax Verification Letter prior to any such extension or renewal.