

MoT Section	740	TAC Section	2.3.12
-------------	-----	-------------	--------

740 ROUNABOUTS

740.01 INTRODUCTION

The Ministry has selected the 2003 *Kansas Roundabout Guide* (KRG) as our primary resource. The KRG is a supplement to the FHWA publication *Roundabouts: An Informational Guide*. The KRG provides more recent information than the FHWA guide on roundabout design based on the ever evolving state of the art in North America.

The KRG, this chapter (740), and the Ministry's roundabout signing and pavement marking guidelines shall be utilized and applied to all roadways under BC MoT jurisdiction.

The KRG is available at:

http://www.ksdot.org/burtraffice/roundabouts/roundabout_guide/roundaboutguide.asp

The FHWA guide is available at:

<http://www.tfrc.gov/safety/00068.htm>

Many of the parameters in roundabout design publications are predicated on urban roadways where there are relatively few large trucks; however, the Ministry primarily deals with provincial and inter-provincial roadways that handle significant volumes of large trucks. Past experience has shown that trucks have not been given enough consideration with respect to designing an appropriate inscribed circle diameter (ICD) and truck apron. The recommendations in this chapter are intended to preserve mobility on Ministry roadways and improve accommodation of large trucks. This chapter also outlines some specific design guidelines for roundabouts in general.

740.02 GENERAL

Background:

The Ministry has gained and continues to gain experience with the principles of roundabout design. As roundabouts are still relatively new on provincial roads there is a benefit to be gained from including

HQ engineering in projects and designs handled by MoT regions and districts whether they are from consultants, municipalities, land developers, or developed in-house. HQ's engineering role is to review and provide feedback on the geometric design, traffic signing, and pavement marking of roundabouts with the goal of achieving province wide harmonization for roundabouts. This process will also allow for 1) applying "lessons learned" to avoid past operational problems, and 2) providing designers with design principles, which due to the evolving nature of roundabout design, have yet to be included in the BC Supplement to TAC Geometric Design Guide.

Policy:

Roundabouts shall be considered as the first option for intersection designs where 4-way stop control or traffic signals are supported by traffic analysis. If an intersection treatment other than a roundabout is recommended, the project documentation should include a reason why a roundabout solution was not selected for that location. This roundabouts "first" policy supports the province's Climate Action Program of 2007.

Roundabouts shall be considered on all roadways including intersections at interchange ramps.

All roundabout designs must be reviewed by the Chief Engineer's Office for provincial consistency. The review starts at the **Conceptual Design** stage allowing for HQ engineering input prior to any roundabout drawings being developed.

Procedure:

After initial discussion with the MoT, all roundabout documentation is to be sent to the attention of the Ministry's contacts (the Senior Traffic Engineer and the Senior Geometric Standards Engineer) at Headquarters Engineering Branch. This shall be coordinated through the primary Ministry contact for a project in the Regional Design office (or District office). All comments and recommendations from HQ will be sent to the Ministry contact.

MoT Section	740	TAC Section	2.3.12
-------------	-----	-------------	--------

Submissions should include the following documentation:

1. Background information/history for need of traffic control
2. Intersection control analysis (Ministry's signal and/or 4-way stop control analysis)
3. *Roundabout Design Criteria Sheet* (including estimated volume by vehicle class and bicycle volume/route information)
4. Roundabout design drawings (in Adobe PDF and AutoCAD DWG format) including, but not limited to: the roundabout superimposed on an aerial photograph, if photos are available; design vehicle turning movements; geometrics and laning; profiles; typical sections; signing and pavement markings
5. SIDRA roundabout analysis provided to MoT with an electronic copy of project file, (include an analysis of emission rates, delay times, and fuel consumption between the use of a traffic signal and roundabout)
6. In British Columbia roundabouts are a relatively new form of traffic control which may lead to some resistance from the public on their use. Consequently, there should be a communication plan established for educating stakeholders and gaining acceptance of a roundabout in a community (e.g. discuss with elected officials, hold public meetings and open houses, distribute brochures, post roundabout information on City and Ministry websites, have computerized simulations of traffic operations, place newspaper advertisements, make Public Service Announcements, make presentations to seniors groups, provide all media outlets with background information, etc.)

The review carried out will deal with the traffic analysis and general layout of the roundabout, the geometric design of the roundabout, the traffic signing of the roundabout, and the pavement marking of the roundabout. Reviews will be done at the conceptual design stage for any proposed roundabout and will continue on through the submission stages until the final design submission.

This roundabout review process does not replace the designer's/design team's quality management process nor does it relieve the Engineer of Record of their responsibility. For consultant designs, the roundabout review by HQ does not preclude any requirements for review and acceptance of the entire project by the Regional Traffic and Design offices or the District office.

740.03 INTERSECTION ANALYSIS

Refer to KRG Section 4.1

The Ministry's software analysis tool is SIDRA. When roundabout drawings are submitted to the Ministry for review, a digital copy of the SIDRA project file is to be part of the submission.

For compatibility, contact the Ministry to find out what version of SIDRA is required.

740.04 GEOMETRIC DESIGN

Refer to KRG Chapter 6

Design Vehicle:

Refer to KRG Section 6.1

On all numbered highways, a roundabout shall be designed with a sufficient inscribed circle diameter and truck apron width to accommodate a WB-20 unless otherwise agreed upon by the Ministry and documented in the roundabout design criteria sheet. The design vehicle shall be determined based on several factors, including but not limited to, the classification of roadways involved, their location (e.g. urban or rural, commercial/industrial or residential), and the vehicle classes (i.e. % of trucks) and volume of vehicles using the intersection. In some instances, this may result in a design vehicle that is smaller or larger than a WB-20 (e.g. on a route that has the occasional permitted over-width or over-length load). Field testing for some roundabout designs may be needed to ensure the largest design vehicle can traverse the proposed roundabout. This can be achieved by laying out (in a large open lot) the central island, truck apron, and inscribed circle diameter (ICD) and having the design vehicle negotiate all possible movements.

MoT Section	740	TAC Section	2.3.12
-------------	-----	-------------	--------

Inscribed Circle Diameter:

Refer to KRG Section 6.1

The BC MoT recommended inscribed circle diameter ranges are as follows:

Table 740.A Recommended Inscribed Circle Diameter (ICD) Ranges

Site Category	Inscribed Circle Diameter Range*
Urban Single Lane	37 – 46 m
Urban Double Lane	46 – 67 m
Rural Single Lane	40 – 61 m
Rural Double Lane	53 – 76 m

* Assumes approximately 90-degree angles between entries and no more than four legs.

Figure 740.A provides turning width requirements for a WB-20 design vehicle for a variety of ICDs. The values provided in Figure 740.A are based on the Surface Transportation Assistance Act (STAA) design vehicle which is similar to the dimensions of the TAC WB-20 design vehicle.

Values in Table 740.A and Figure 740.A were derived by converting imperial measurements to metric.

Figure 740.A Required Turning Widths

(from “Roundabout Design Guidelines” Ourston Roundabout Engineering 2001)

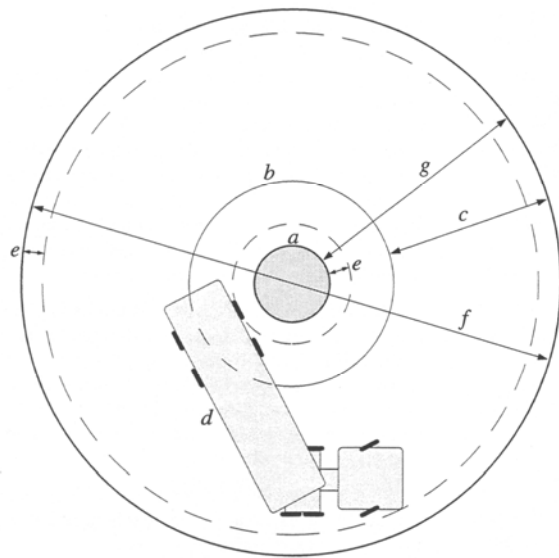

LEGEND

- a Raised central island.
- b Low profile mountable apron.
- c Remaining circulatory roadway width, 1.0-1.2 times the maximum entry width.
- d Design vehicle.
- e 1 meter clearance minimum.
- f Inscribed circle diameter (ICD).
- g Width between curbs.

NOTE: Splitter islands should not protrude into the inscribed circle if the roundabout is designed tightly as illustrated here, allowing only the minimum width g.

Inscribed Circle Diameter (f) (metres)	Design Vehicle WB-20 (g) (metres)
79.2	7.2
73.2	7.5
67.1	7.8
61.0	8.1
57.9	8.4
54.9	8.7
51.8	9.0
48.8	9.3
45.7	9.8
42.7	10.1
39.6	11.1
36.6	12.2
33.5	13.7
30.5	**
29.0	**

** Design Vehicle requires larger ICD

MoT Section	740	TAC Section	2.3.12
-------------	-----	-------------	--------

Number of Lanes:

Refer to KRG Section 6.1

On two lane provincial numbered routes, the main highway approach legs shall be developed with two lane entries. The exit legs may be either one or two lanes depending on traffic volumes and turning movements. Figures 740.G, 740.H and 740.I are sketched examples of roundabouts with one and two lane approaches and exits. When utilized, two lane exits shall be carried a minimum of 175 m beyond the roundabout before tapering back to a single lane. Lengths less than 175 m must be approved as a design exception with the appropriate Ministry sign off.

(Note: a “numbered” route refers to a road that has an official guide sign route marker; ex. Hwy 3, Hwy 5, Hwy 97, etc.)

Single lane roundabouts are typically used on two lane un-numbered roadways under the jurisdiction of the Ministry.

Four lane and six lane highways will have two or three entry and circulating lanes. Figure 740.J is an example of a roundabout with 3-lane approaches and exits on the primary route.

Bypass lanes are an option that should be considered when there are high volumes of right turn traffic (especially if there is a significant volume of tractor-trailer vehicles). If traffic projections warrant a bypass lane within 10 years from the opening date, the bypass lane should be constructed as part of the initial project. If a bypass lane will be warranted beyond 10 years, sufficient right-of-way should be protected to accommodate the future construction.

Figure 740.B provides an indication of expected capacities of single and multi-lane roundabouts. Figure 740.B is based on the acceptable degree of saturation being less than 0.8.

Figure 740.B Required Number of Entry and Circulating Lanes

(from the Austroads *Guide to Traffic Engineering Practice, Part 6 - Roundabouts*)

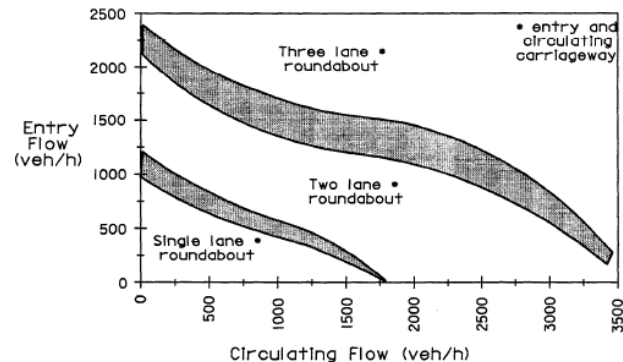

The shaded bands indicate conditions in which either treatment may be suitable depending on the geometry and acceptable operating conditions.

Circulatory Roadway:

Refer to KRG Section 6.1

(Note: the gutter portion of curbing is not considered to be part of the circulatory width or ICD.)

For two lane roundabouts with significant truck volumes, the total circulatory (i.e. paved) width should, at a minimum, accommodate the largest frequent design vehicle (typically a WB-20) side by side with a passenger car. This does not necessarily mean that the truck must stay within its painted lane.

For single lane roundabouts, the paved circulatory width should accommodate an intercity bus (TAC I-BUS) which is also representative of large emergency vehicles (i.e. fire trucks). Vehicles larger than the TAC I-BUS are expected to utilize the truck apron.

Camel-backs should be avoided. Figure 740.C shows an example of where the circulatory roadway is not being utilized in the camel-back area. The natural drive path for right turning vehicles does not pass through the camel-back area. On multi-lane roundabouts, this will create a path overlap hazard.

MoT Section	740	TAC Section	2.3.12
-------------	-----	-------------	--------

Figure 740.C Example of a Camel-back
(see KRG Exhibit 6-25 for a larger picture)

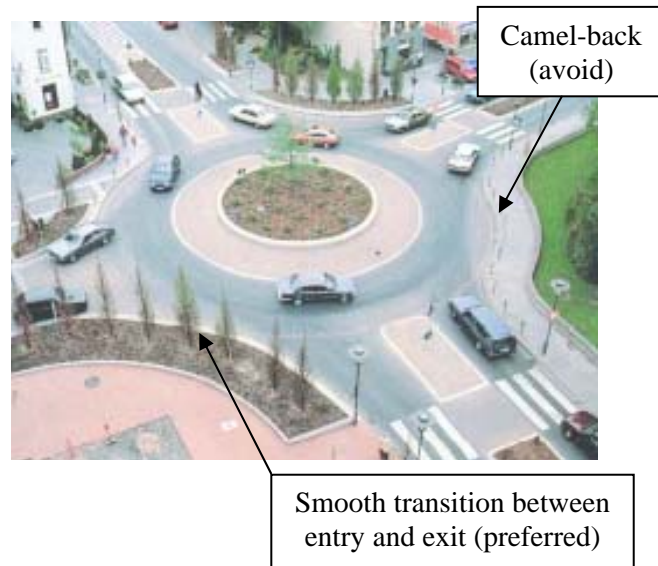

- the circulatory radius, R_2 ;
- the distance from the end of the R_2 radius to the exit crosswalk; and
- the acceleration from the end of R_2 to the exit crosswalk.

This assumes that drivers accelerate immediately as they reach the end of R_2 . (This is very aggressive and usually there is a time lag.) The acceleration rate is about 3.5 ft/sec/sec (it may vary depending on the initial R_2 speed).”⁽¹⁾

In most situations, the relatively short distance at the exit between the circulating roadway and the pedestrian crossing will typically result in an acceleration of 5 to 10 km/h. Figure 740.D shows an example of large radii exits. Due to the entry deflection (see Figure 740.F), the east bound exit speed was calculated to be only 30 km/h.

Exits:

Refer to KRG Section 6.1

Contrary to the KRG discussion on exits, the exit path radius (R_3) may be significantly greater than the circulating path radius (R_2) provided that the entry and circulating paths have been designed to ensure a low operating speed.

“The designer should consider the driver’s stopping sight distance and pedestrian decision and crossing time. The pedestrian needs to interpret the drivers’ intentions (to exit or circulate) with adequate time to complete the crossing. With a relaxed exit path, the driver’s intentions are apparent to the pedestrian earlier. The pedestrian crossing is also visible to the driver earlier, so the stopping sight distance is improved. If vehicle speed is reduced prior to the entry, and the Inscribed Circle Diameter (ICD) is smaller, cars will tend to circulate slower, and if the pedestrian is clearly visible (as they are on a more tangential exit), reasonable drivers do not accelerate at them as they begin their exit.

Exit speed can be calculated based on circulating speed and acceleration rate, starting from the circulating speed at the point where drivers round the central island and begin their exit path curve. On multi-lane roundabouts at off-peak times, the fastest-path exit speed depends not on R_3 (too large to have any effect) but on the following:

Figure 740.D Example of Large Radii Exits at a 3-Legged Roundabout
(Okemos, Michigan)



Note: Signing and lighting shown in this picture do not meet Ministry guidelines.

Multilane Entry Design:

Refer to KRG Section 6.2

The preferred design to increase entry deflection shall be an approach alignment “offset left” of the roundabout center as shown in KRG Exhibit 6-22 and Figure 740.E. When designing for large trucks, consideration should be given to using an entry curve radius that is large enough to avoid trailers dangerously overtracking into the adjacent lane prior to the yield line. This could require entry curve radii of 30 m or more, but it is also important that the

MoT Section	740	TAC Section	2.3.12
-------------	-----	-------------	--------

radii not be so large as to allow excessive entry speeds.

Figure 740.E shows a 2-lane entry technique that will reduce the wheel path conflicts between cars and large trucks. A truck can utilize the gore area without encroaching into the adjacent lane.

Figure 740.E Example of Entry Lanes to Accommodate Truck Over Tracking
(from New York DoT)



Vehicles should be directed into the proper circulatory lane at the approach entrance (yield) line. Lane lines should be designed tangential to the roundabout, as shown in KRG Exhibit 6-21.

Figure 740.F Example of Multi-lane Entry Deflection at a 3-Legged Roundabout
(Okemos, Michigan)



Grading and Drainage:

Refer to KRG Section 6.3

In addition to the drainage guidance in the KRG and FHWA publications, special consideration may be required for roundabouts on flat terrain. It is suggested that the entire roundabout be tilted at 0.5% to 1.0% to ensure drainage is directed towards a specific catch basin location.

In consideration of low-boy trailers where ground clearance may be an issue, creating a crown in the roundabout perpendicular to the circulatory roadway should be avoided to prevent these trailers from high centering.

Curbs, Pavement Design, and Truck Aprons:

Curb and pavement designs shall be in accordance with the MoT Standard Specifications for Highway Construction. Where required, splitter island curbing should be designed to resist snowplow activity.

The outer edge of the circulatory roadway and the central island shall be constructed with combined curb and gutter in accordance with SP582-01.01. Modifications, as required, shall be made to the central island gutter slope to ensure drainage does not accumulate against the central island curb. Alternatively, the central island may be constructed with extruded concrete curb in accordance with SP582-01.04.

Along quadrants that do not have sidewalks, the minimum extents of curb and gutter on the outer edge of the roadway shall begin and end where the pedestrian crossing intersects the curb (i.e. about one car length from the entrance line).

A minimum 2.0 m wide central island truck apron shall be installed at all roundabouts (even at large roundabouts where a truck apron is not necessarily required). This will create a visually distinct feature for MoT roundabouts. Truck aprons should be sized to accommodate the design vehicle turning path with approximately 1.0 m clearance between the vehicle’s tire track and the central island curb. There is no standard width for a truck apron; however, the designer should re-evaluate the design to ensure that the proper ICD size and geometric features are being provided if an apron is greater than 4.2 m in width.

MoT Section	740	TAC Section	2.3.12
-------------	-----	-------------	--------

In some situations, a very large truck apron may be an indicator that other geometric features are being compromised in the roundabout design.

Truck aprons shall be constructed with mountable curb and gutter in accordance with SP582-01.02 “Roundabout Truck Apron Mountable Curb”. The mountable curb height shall be 50 mm.

The slope of the truck apron should typically be 2% away from the central island.

The apron shall be built with contrasting materials (texture and color) for better visibility during both day and night conditions. The texture and colour of the material used for the apron shall be different than the material used for the sidewalks so that pedestrians are not encouraged to cross the circulatory roadway. Textures vary from inlaid and stamped asphalt brick patterns to stamped concrete “cobblestones”. Stamped stone patterns provide for a more audible and visual deterrent than brick patterns.

Pedestrian Considerations:

Refer to KRG Section 6.5

Detectable warning surfaces should be installed at the curb letdowns and at the entrances/exits of the pedestrian refuges in the splitter islands. See KRG Exhibit 6-29 for a detail of the detectable warning surface.

The width of sidewalks shall be 1.8 m minimum but the width must be increased where shared use by pedestrians and cyclists is expected. 3.0 m is the typical width provided for a shared use facility.

A landscaping buffer should be provided between the sidewalk and circulatory roadway (see Figure 740.F). This buffer will provide better delineation of the sidewalk for the visually impaired, will deter pedestrians from crossing to the central island, and will provide room for sign installations. The preferred set back distance for the buffer from the back of curb to the sidewalk is 1.5 m; however, a minimum set back distance of 0.6 m is acceptable. Right-of-way constraints at some locations may restrict the use of a buffer; however, this treatment should be utilized wherever possible. The width required for the placement of signs should be taken

into consideration to prevent signs from intruding into the roadway or sidewalk space.

The area between the road and the sidewalk can be planted with grass, flowers, or low shrubbery. If the minimum 0.6 m set back is used, a coloured and/or stamped concrete/asphalt treatment may also be considered.

Landscaping Considerations

Pedestrian safety is paramount at roundabouts; therefore, landscape vegetation must be positioned so that sight lines to the pedestrians are maintained.

Vegetation (e.g. tall trees) must not cast shadows across the pedestrian crossing area.

Vegetation on Ministry roundabouts should be self sustaining. Irrigation provided in urban areas would be maintained by the local jurisdiction.

The use of landscaping at a roundabout is one of the distinguishing features that give roundabouts an aesthetic advantage over traditional intersections. Landscaping can provide an opportunity for gateway treatments that promote community themes/branding or identification.

Design Exceptions

All design exceptions to the above guidelines must be documented in the roundabout design criteria sheet and approved by the Ministry.

MoT Section	740	TAC Section	2.3.12
-------------	-----	-------------	--------

740.05 TRAFFIC DESIGN

Refer to KRG Chapter 7

Signing and Pavement Marking:

The Ministry's signing and pavement marking guidelines for roundabouts are available as a Technical Circular at:

http://www.th.gov.bc.ca/publications/Circulars/Current/T_Circ/2005/t07-te-2005-5.pdf

This Technical Circular is occasionally updated; therefore, the website should be checked for the latest version at the start of each project.

Central island monuments and other landscaping treatments must be designed to accommodate all regulatory signing requirements.

Lighting Guidelines:

The latest edition of the TAC *Guide for the Design of Roadway Lighting* is to be used for roundabout lighting designs.

740.06 REFERENCES

1. Baranowski, Bill and Waddell, Edmund.
Alternate Design Methods for Pedestrian Safety at Roundabout Entries and Exits: Crash Studies and Design Practices in Australia, France, Great Britain and the USA, 2003

MoT Section	740	TAC Section	2.3.12
-------------	-----	-------------	--------

Figure 740.G Roundabout Layout Example – Intersection of Major Route with Minor Route

Two-Lane Entries and Exits on Major Route
One-Lane Entries and Exits on Minor Route

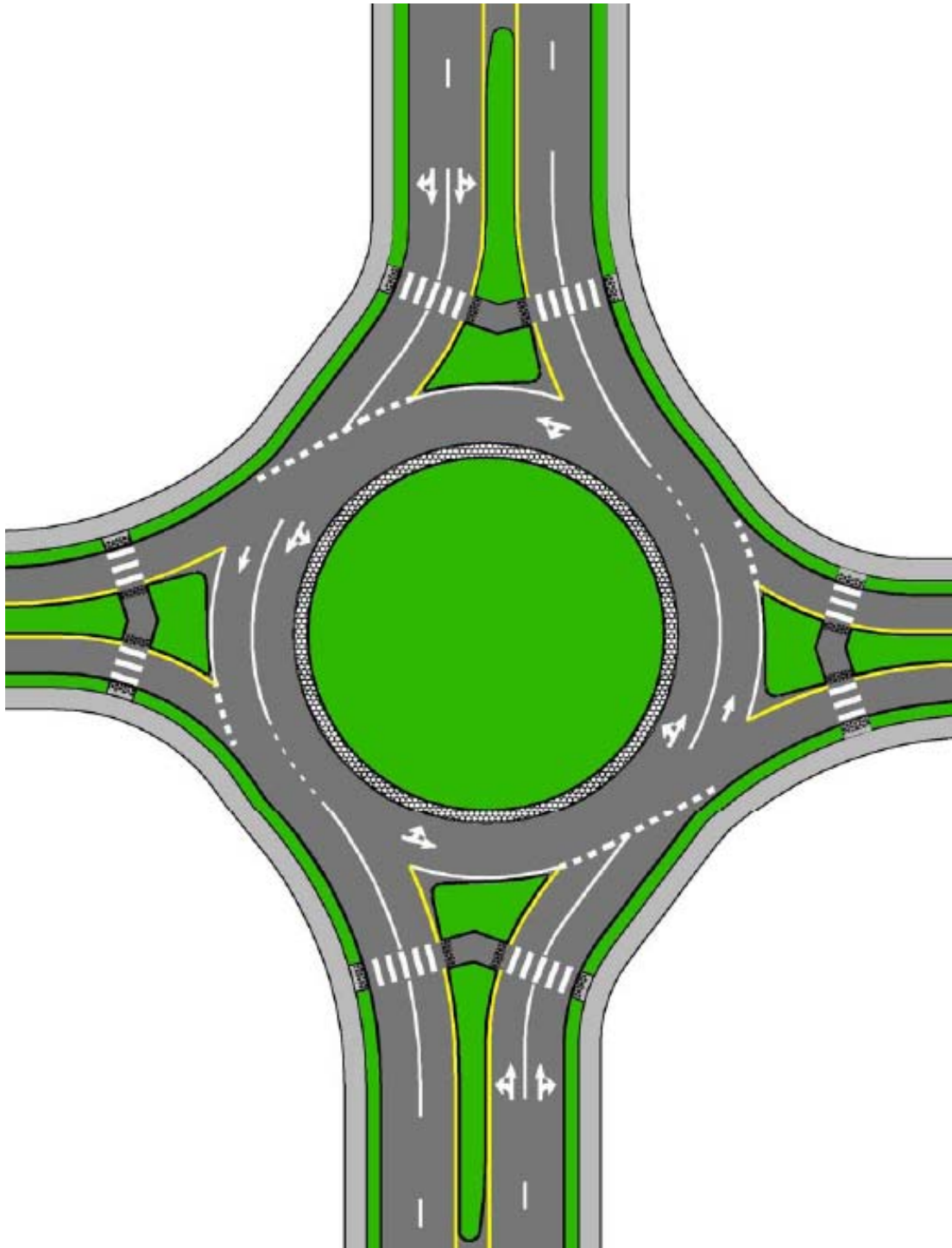

MoT Section	740	TAC Section	2.3.12
-------------	-----	-------------	--------

Figure 740.H Roundabout Layout Example – Intersection of Major Route with Minor Route

Two-Lane Entries and One-Lane Exits on Major Route
One-Lane Entries and Exits on Minor Route

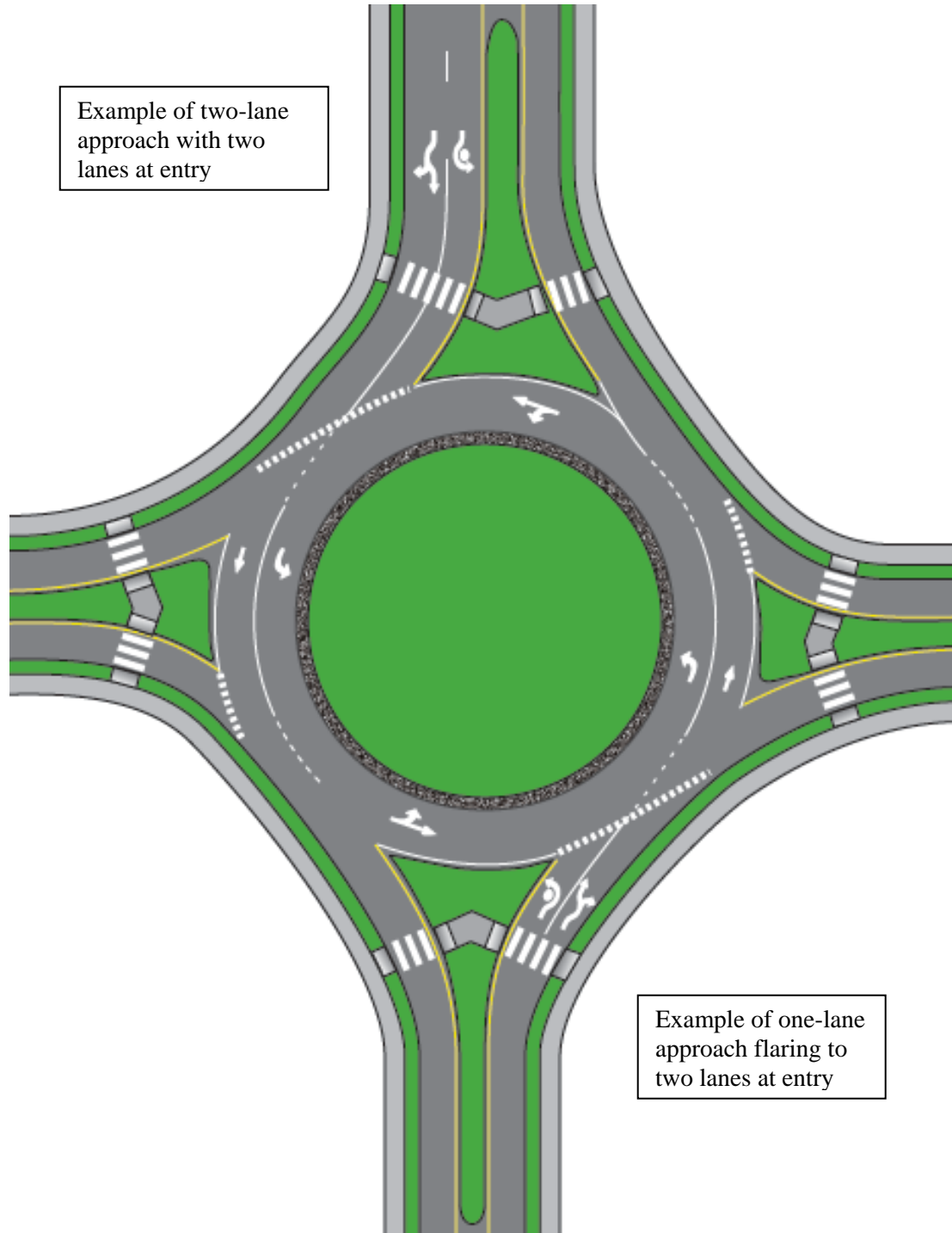

MoT Section	740	TAC Section	2.3.12
-------------	-----	-------------	--------

Figure 740.I Roundabout Layout Example – Intersection of Two Major Routes

Two-Lane Entries and One-Lane Exits on All Routes

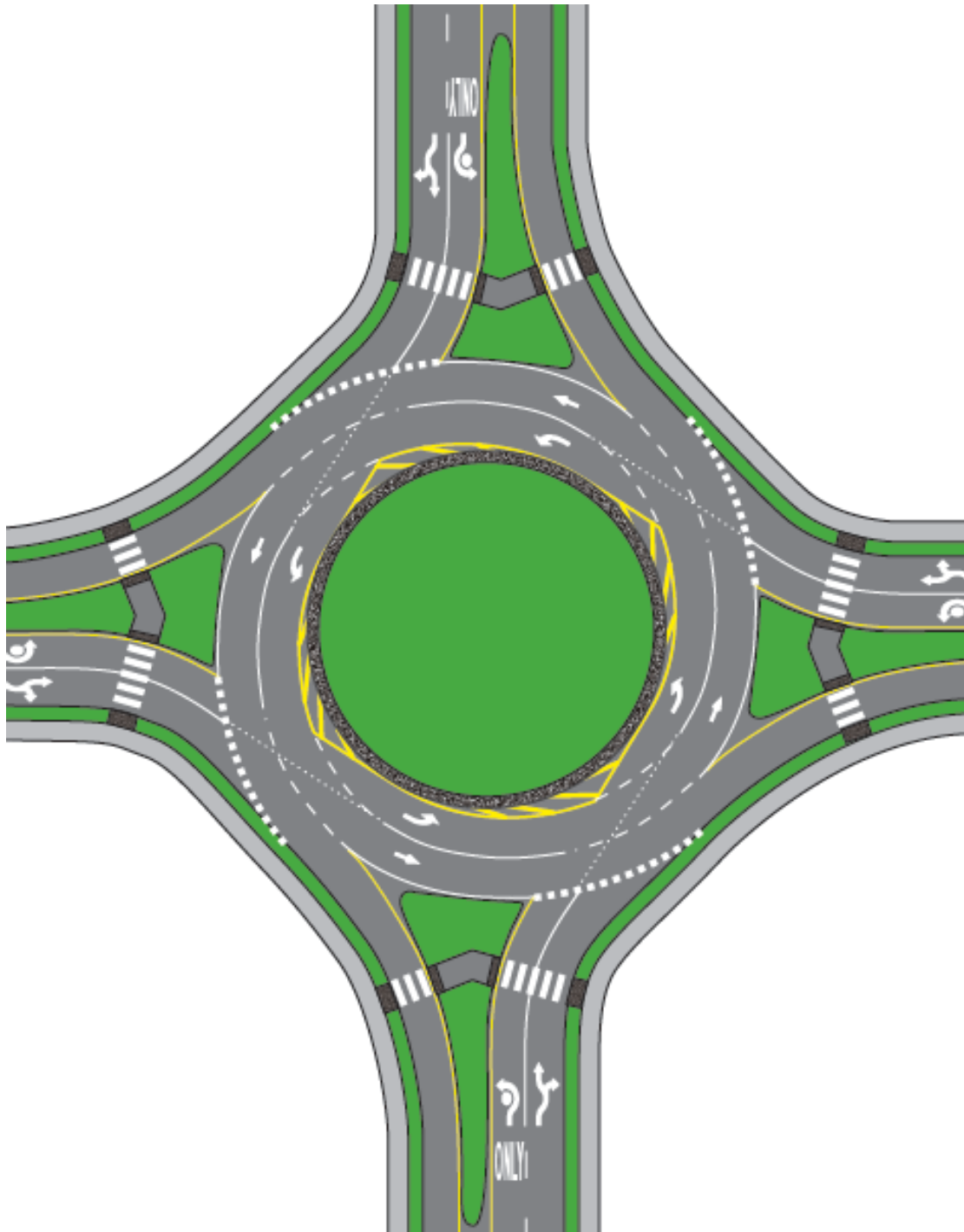

MoT Section	740	TAC Section	2.3.12
-------------	-----	-------------	--------

Figure 740.J Roundabout Layout Example – Intersection of Two Major Routes

Three-Lane Entries and Three-Lane Exits on Primary Route

(Sterling Heights, Michigan
18½ Mile Road and M-53)

