

SECTION **A**

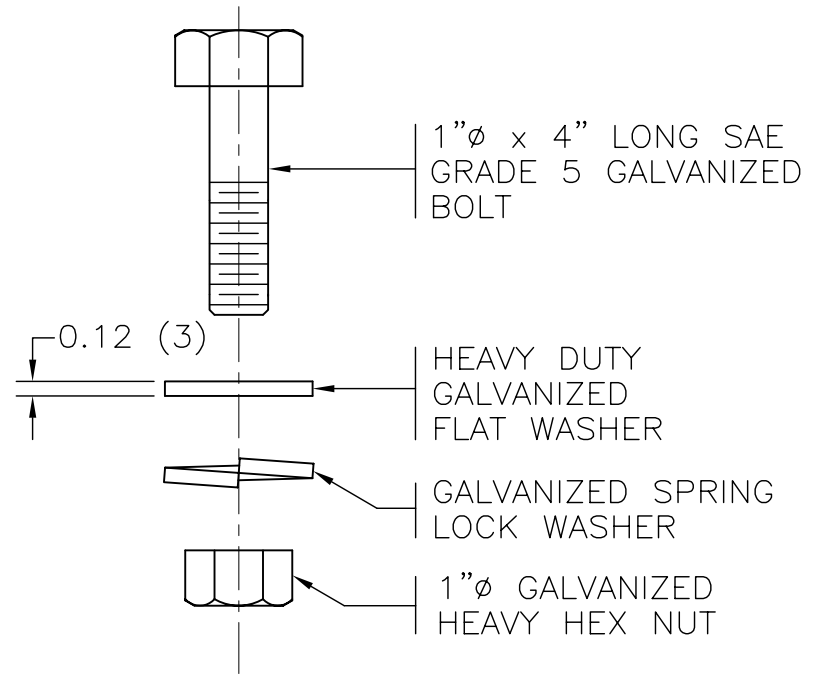

BOLT DETAIL
(4 REQUIRED)

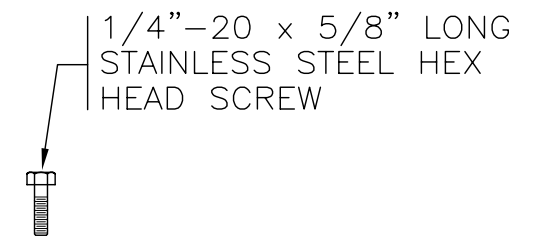

HANDHOLE COVER SCREW DETAIL
(2 REQUIRED)

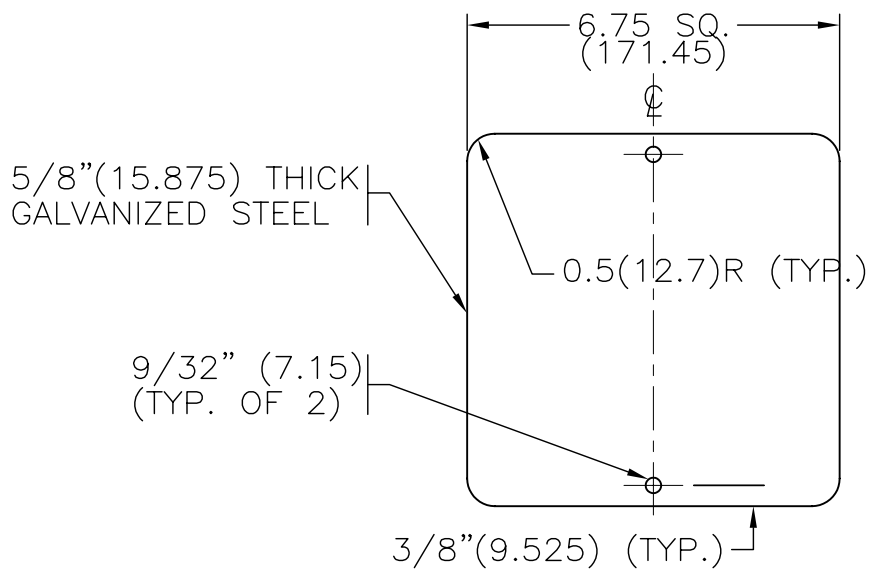

HANDHOLE COVER DETAIL
(1 REQUIRED)

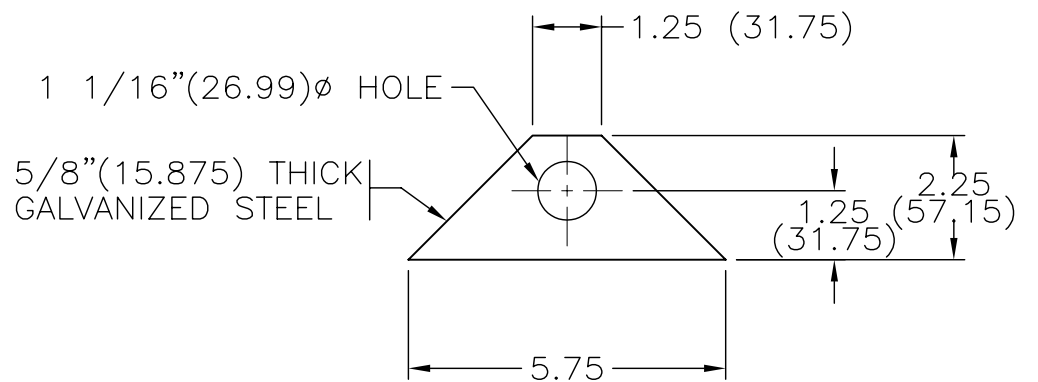

TRANGULAR WASHER DETAIL
(8 REQUIRED)

SEE DRAWING MS340.1 FOR ADDITIONAL NOTES

SCALE 1:5

No.	Revision	Date
F		
E		
D		
C		
B		
A		

ALUMINUM FRANGIBLE BASE DETAILS



BRITISH COLUMBIA

**Ministry of
Transportation
and Highways**

SPECIFICATION
DRAWING No.
MS340.2