

2 1/2" (I.P.S.)  
SCHEDULE 40 PIPE.

25 $\phi$  DRAIN HOLE

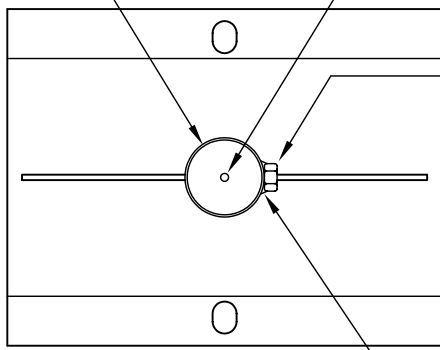

DRILL 14 $\phi$  HOLE IN  
PIPE AND WELD  
1/2"  $\phi$  HEX NUT TO  
PIPE

TOP VIEW

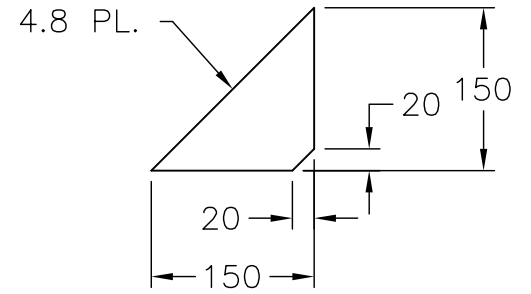

STIFFENER PLATE  
(TYPICAL 2 LOCATIONS)

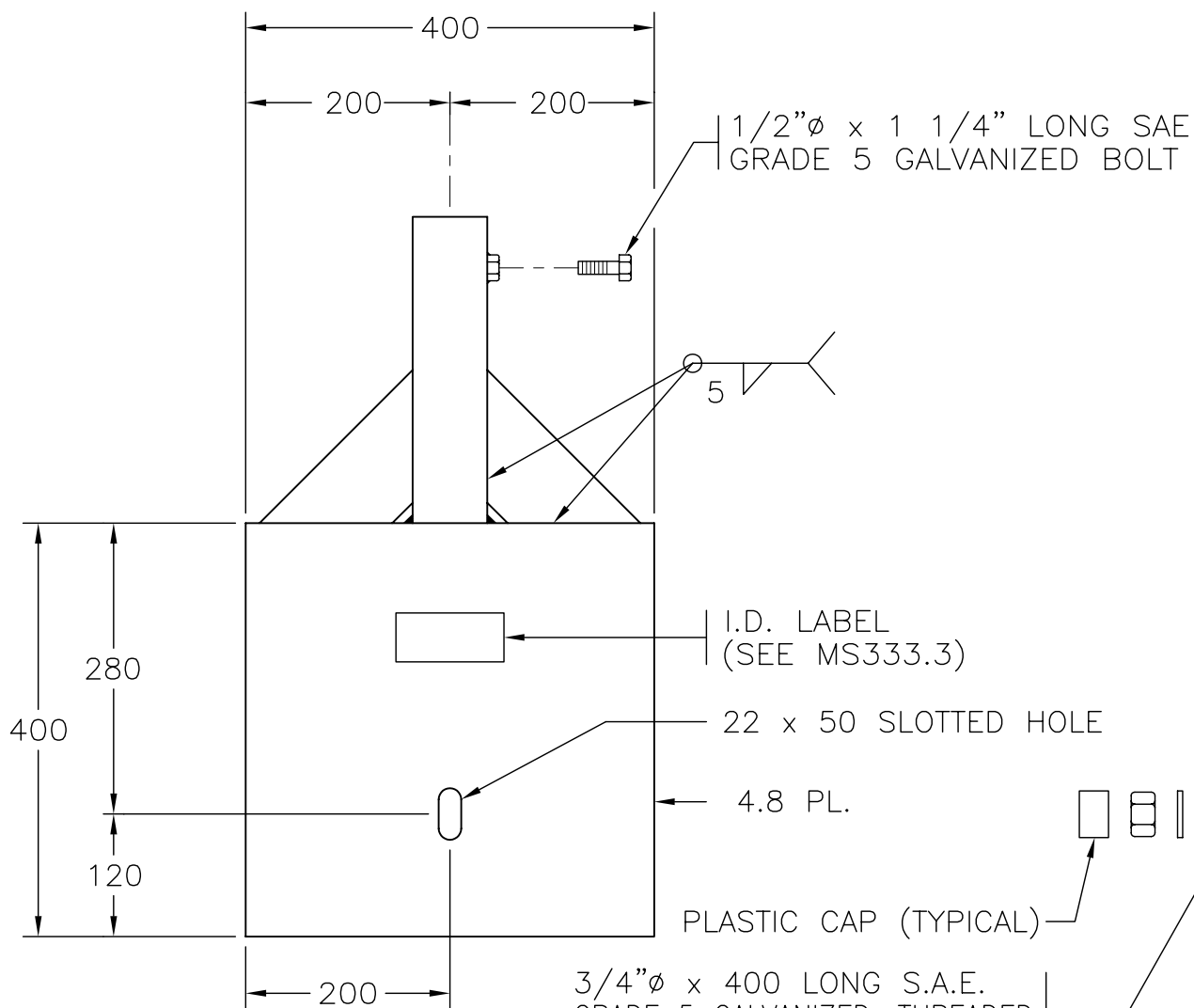

FRONT VIEW

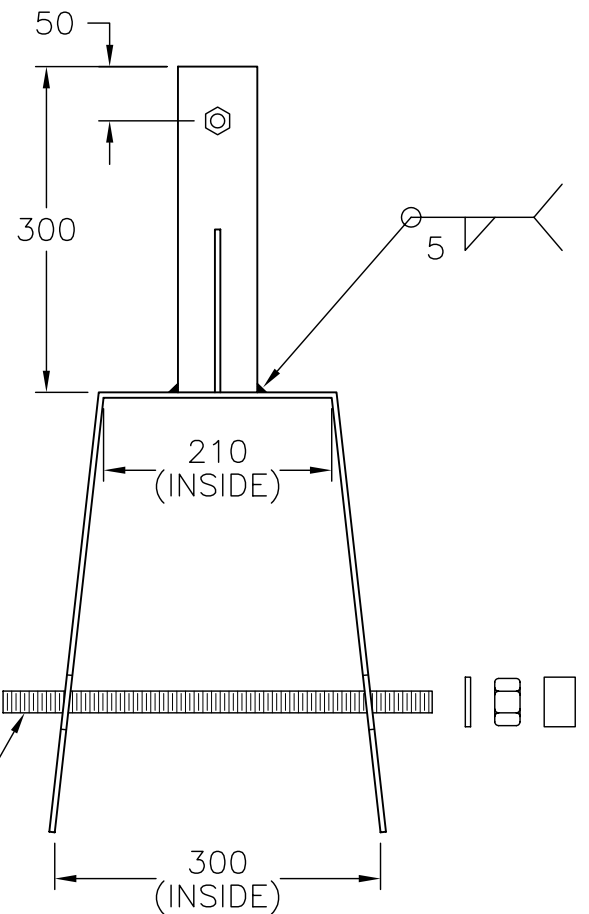

SIDE VIEW

CRB SIGN STAND  
(SN2181)

NOTES

1. SEE MATERIAL STANDARD SPECIFICATIONS SECTION 303 – BARRIER SIGN STANDS FOR ADDITIONAL INFORMATION.
2. ALL DIMENSIONS ARE IN MILLIMETRES UNLESS OTHERWISE NOTED.
3. 'SN' DENOTES MINISTRY STOCK NUMBER.

CRB BARRIER STAND MASS
22 kg

SCALE 1:10

No.	Revision	Date
F		
E		
D		
C		
B		
A		

CONCRETE ROADSIDE BARRIER (CRB)  
SIGN STAND DETAILS



BRITISH  
COLUMBIA

Ministry of  
Transportation  
and Highways

SPECIFICATION  
DRAWING No.  
MS333.2