

8.4 Materials .....	3
8.4.1 Concrete .....	3
8.4.1.1 Compliance with CSA A23.1/23.2 and CSA A23.4 .....	3
8.4.1.2 Compressive strength .....	3
8.4.1.2.1 Specified compressive strength .....	3
8.4.1.5 Modulus of elasticity .....	3
8.4.1.5.1 General .....	3
8.4.2 Reinforcing bars and deformed wire .....	3
8.4.2.1 Reinforcing bars .....	3
8.4.2.1.1 Specification .....	4
8.4.2.1.2 Welding .....	4
8.4.2.1.3 Yield strength .....	4
8.6 Design considerations .....	5
8.6.1 General .....	5
8.7 Prestressing requirements .....	5
8.7.4 Loss of prestress .....	5
8.7.4.1 General .....	5
8.8 Flexure and axial loads .....	5
8.8.4 Flexural components .....	5
8.8.4.5 Maximum reinforcement .....	5
8.9 Shear and torsion .....	5
8.9.3 Sectional design model .....	5
8.9.3.8 Determination of $\epsilon_x$ .....	5
8.11 Durability .....	6
8.11.2 Protective measures .....	6
8.11.2.2 Concrete quality .....	6
8.11.2.2.1 General .....	6
8.11.2.3.2 Concrete placement .....	9
8.11.2.3.5 Slip-form construction .....	11
8.11.2.3.6 Finishing .....	11
8.11.2.4 Concrete cover .....	12
8.11.2.5 Corrosion protection for reinforcement, ducts and metallic components .....	14
8.11.2.5.1 General .....	14
8.11.2.5.2 Corrosion protection for bridge decks, parapets, curbs and approach slabs .....	14
8.11.2.5.3 Corrosion protection for components subject to spray or surface runoff containing de-icing chemicals .....	16
8.11.2.6 Drip Grooves .....	17
8.11.2.7 Waterproofing .....	17
8.12 Control of Cracking .....	18
8.12.1 General .....	18
8.13 Deformation .....	19
8.13.3 Deflections and rotations .....	19
8.13.3.3 Total deflection and rotation .....	19
8.14 Details of reinforcement and special detailing requirements .....	19

8.14.3 Transverse reinforcement for flexural components.....	19
8.15 Development and splices.....	20
8.15.7 Combination development length.....	20
8.15.10 Splicing of reinforcement.....	20
8.15.10.1 Lap splices .....	20
8.15.10.2 Welded splices .....	21
8.16 Anchorage zone reinforcement .....	21
8.16.7 Anchorage of attachments .....	21
8.18 Special provisions for deck slabs.....	21
8.18.1 Applicability.....	21
8.18.2 Minimum slab thickness .....	21
8.18.2.4 Allowance for wear .....	21
8.18.3 Empirical design method .....	22
8.18.3.4 Cast-in-place deck slabs on precast panels.....	22
8.18.3.4.3 Cast-in-place topping .....	22
8.18.3.5 Full-depth precast panels.....	22
8.18.4 Diaphragms .....	25
8.19 Composite construction.....	25
8.19.1 General.....	25
8.19.3 Shear .....	25
8.20 Concrete girders.....	27
8.20.1 General.....	27
8.20.3 Flange Thickness for T and Box Girders .....	27
8.20.3.2 Bottom Flange.....	27
8.20.6 Post-Tensioning Tendons.....	27
8.20.7 Diaphragms .....	28
8.21 Multi-beam decks .....	30
ANNEX A8.1 Fibre-reinforced concrete (FRC).....	32
A8.1.1 General .....	32

## 8.4 Materials

### 8.4.1 Concrete

#### 8.4.1.1 Compliance with CSA A23.1/23.2 and CSA A23.4

Delete and replace with the following:

Materials, methods of material testing, and construction practices shall comply with the following, unless otherwise Consented to by the Ministry, based on the order of precedence as listed below:

- Ministry Supplement to CHBDC S6-19
- Ministry Standard Specifications for Highway Construction (SS and DBSS)
- CSA A23.1/A23.2 and CSA A23.4

#### 8.4.1.2 Compressive strength

##### 8.4.1.2.1 Specified compressive strength

*Commentary:* The specified concrete strength for prestressed I girders and box girders should not exceed 55 MPa at 28 days or 37.5 MPa at release. These strength limits enable the prestressed girders to be manufactured with efficient turnaround times for release and handling. Modifications to these strength limits should be discussed with the Ministry and the precast girder manufacturers to enable efficient design and manufacture.

#### 8.4.1.5 Modulus of elasticity

##### 8.4.1.5.1 General

Add the following:

The design values of modulus of elasticity at transfer and 28 days shall be shown on the plans for all prestressed girders.

*Commentary:* With use of new materials in concrete mix designs for prestressed girders, such as use of GUL cement, the Ministry will be gathering data for the modulus of elasticity from prestressed concrete girder suppliers.

*Designers should check that their designs accommodate the values of modulus of elasticity of concrete available from prestressed concrete girder suppliers.*

### 8.4.2 Reinforcing bars and deformed wire

#### 8.4.2.1 Reinforcing bars

Add the following:

Carbon steel reinforcing bar layouts shall be based on standard reinforcing bar lengths of 12 m for 10M bars and 18 m for 15M bars and greater. Stainless steel reinforcing bar layouts shall be based on standard reinforcing bar lengths of 11.89 m.

**Commentary:** *Standard reinforcing bar lengths are based on typical bar lengths which are currently available from reinforcing steel suppliers.*

#### 8.4.2.1.1 Specification

Add the following:

Reinforcing bars shall be in accordance with SS412 and DBSS 412.

Other reinforcing bar types are permitted for use when Consented to by the Ministry.

The designer shall consider and address the difference between metric and imperial bar sizes when specifying the use of solid stainless reinforcing bars or low carbon/chromium reinforcing steel. Design for stainless steel reinforcing shall be based on Canadian metric bars and a conversion table for allowable substitutions with imperial or non-Canadian metric bars shall be provided in the Plans. Design for low carbon/chromium steel reinforcing shall be based on imperial bars and a conversion table for allowable substitutions with metric bars shall be provided in the Plans.

**Commentary:** *Solid stainless reinforcing bars are available in both European metric and imperial sizes, while low carbon/chromium reinforcing steel meeting the requirements of ASTM A1035 is currently only available in imperial sizes.*

#### 8.4.2.1.2 Welding

Replace the second paragraph with the following:

Welded splices and tack welding of reinforcing shall only be allowed when Consented to by the Ministry.

#### 8.4.2.1.3 Yield strength

Add the following:

Grade 400W reinforcing bars shall be specified for flexural reinforcement in plastic hinge regions, unless otherwise Consented to by the Ministry.

For bridge decks, the design yield strength shall be 420 MPa for stainless steel and low carbon/chromium reinforcing steel. The Plans shall note that details such as lap lengths shall be adjusted by the contractor at their cost to the satisfaction of the engineer if higher yield strength material is proposed by the contractor during construction.

**Commentary:** *Use of Grade 400W bars is intended to ensure plastic hinge regions possess expected ductility characteristics.*

*For Grade 400W reinforcing bars, an upper limit for yield strength of 525 MPa is a requirement of CSA-G30.18.*

There are corrosion resistant and stainless steel reinforcing grades with yield strength greater than 420 MPa and a stress-strain curve differing from Grade 400 reinforcing steel. These differences shall be considered in the design, in particular with respect to assumption for moment redistribution or seismic design considerations.

## 8.6 Design considerations

### 8.6.1 General

Add the following:

Connection details for precast concrete components shall be designed to address the potential for cracking in the concrete at the connections. The designer shall pay special attention to the size and type of welds for embedded connections to mitigate the potential for damage to the concrete from the heat of welding.

*Commentary:* The Ministry has observed concrete cracking near welded connections at precast concrete components. Details should be carefully designed to address this issue.

## 8.7 Prestressing requirements

### 8.7.4 Loss of prestress

#### 8.7.4.1 General

*Commentary:* The losses tabulated in Table C8.2 may be unconservative for prestressed girders where the span to depth ratio is high.

## 8.8 Flexure and axial loads

### 8.8.4 Flexural components

#### 8.8.4.5 Maximum reinforcement

Replace the second sentence with the following:

This requirement may be waived if Consented to by the Ministry if it is demonstrated that the consequences of reinforcement not yielding are acceptable.

## 8.9 Shear and torsion

### 8.9.3 Sectional design model

#### 8.9.3.8 Determination of $\epsilon_x$

*Commentary:* For the design and evaluation of prestressed girders, the capacity-enhancing effect of negative strains (compressive) near supports may be taken into account using generally accepted approaches.

## 8.11 Durability

### 8.11.2 Protective measures

#### 8.11.2.2 Concrete quality

##### 8.11.2.2.1 General

Delete the entire clause and replace with the following:

Concrete mix design parameters shall be determined in consultation with the Ministry and shall comply with the requirements given in Table 8.4 unless otherwise Consented to by the Ministry. The information, for each relevant classification of concrete, shall be included in the Special Provisions for the Project.

For structural concrete not covered by Table 8.4, the maximum water to cementitious materials ratio shall be 0.45 unless otherwise Consented to by the Ministry.

Entrained air content for all concrete mixes shall be in accordance with CSA A23.1, Table 4, Air content category 1, except that the air content shall be measured at the point of placement.

Mix design parameters for concrete subject to Very Severe degree of exposure to sulfate attack (CSA A23.1 Class of Exposure S-1) shall be determined in consultation with the Ministry and shall be Consented to by the Ministry.

Cement type shall be GU or GUL unless otherwise Consented to by the Ministry.

Low-density and Semi-low-density concrete shall not be used in any bridge component.

**Commentary:** A23.1-24, Clause 8.2 Mass Concrete considers mass concrete may include elements having a minimum dimension equal to or greater than 1 metre. The requirements of Clause 8.2 shall be considered when developing mix design requirements and Special Provisions, including but not limited to:

- *Temperature requirements*
- *Cementitious material contents*
- *Temperature monitoring*
- *Thermal control plans.*

**Table 8.4**  
**Cast-in-Place Concrete mix design parameters**

Exposure <sup>(1)(2)</sup>	Minimum Compressive Strength at 28 days (MPa)	Nominal Maximum Size of Coarse Aggregate (mm)	Slump <sup>(3)</sup> (mm)	Maximum w/cm Ratio by Mass
<b>Deck Concrete<sup>(4)(7)</sup>: Deck Slab<sup>(6)</sup>, Approach Slab<sup>(6)</sup>, Parapet and Median Barrier, Bridge sidewalk, Diaphragm</b>				
Late chloride exposure <sup>(13)</sup>	35	20 <sup>(8)(10)</sup>	80 ± 20	0.38
Early chloride exposure <sup>(14)</sup>	35	20 <sup>(8)(10)</sup>	80 ± 20	0.38
<b>Substructure Concrete: Piers<sup>(5)</sup>, Abutments<sup>(5)</sup>, Retaining Walls<sup>(5)</sup>, Footings<sup>(5)</sup>, Pipe Pile In-fills<sup>(9)</sup>, Working Floors</b>				
All chloride and sulphate exposures except Class S-1 <sup>(11)(15)</sup>	30	20 <sup>(10)</sup>	120 ± 30	0.40
<b>Deck Overlay Concrete<sup>(4)(6)(7)</sup>:</b>				
Late and Early chloride exposure <sup>(14)</sup>	45	14	80 ± 20	0.38
<b>Keyways between Box Stringers<sup>(4)(12)</sup>:</b>				
Late chloride exposure <sup>(13)</sup>	35	14	80 ± 20	0.38
Early chloride exposure <sup>(14)</sup>	35	14	80 ± 20	0.38
<b>Concrete Slope Pavement<sup>(5)</sup>:</b>				
All chloride and sulphate exposures except Class S-1 <sup>(11)(15)</sup>	30	20 <sup>(10)</sup>	30 ± 20	0.40

**Notes:**

- 1) Early chloride exposure applies to concrete that is not allowed to air-dry for a period of at least one month after the end of the curing period, before exposure to de-icing chemicals. Late chloride exposure applies to concrete that is allowed to air-dry for a period of at least one month after the end of the curing period, before exposure to de-icing chemicals.
- 2) Sulphate exposure classes as per CSA A23.1, Table 3.
- 3) Slump as measured at the final discharge end of the placement system, after addition of admixtures.
- 4) Resistance to chloride ion penetration test results shall be less than 1,000 coulombs at 91 days for late chloride exposure and shall be less than 1,500 at 28 days for early chloride exposure, using test method A23.2-23C or ASTM C1202.
- 5) Resistance to chloride ion penetration test results shall be less than 1,500 coulombs at 91 days using test method A23.2-23C or ASTM C1202.
- 6) For exposed concrete decks that have no added wearing surfaces, the maximum proportion of aggregate passing the 5 mm sieve shall be less than 38% of the total mass of the aggregate. For deck overlay concrete with 14 mm aggregate, the maximum proportion of aggregate passing the 5 mm sieve shall be less than 42% of the total mass of the aggregate.
- 7) Shrinkage limit of the concrete shall be in accordance with CSA A23.1 Clause 8.8 Low-shrinkage concrete and shrinkage test shall be in accordance with CSA A23.2-21C.
- 8) The requirements of Note 7) shall be waived if the total cementitious materials content in the concrete mixture is equal to, or less than 400 kg/m<sup>3</sup> with the use of a Nominal Maximum Size of Coarse Aggregate of 28 mm.
- 9) For deep piles and drilled shafts, the use of a tremie concrete mix that incorporates 14 mm Nominal Maximum Size of Coarse Aggregate and plasticised slump of up to 190 mm ± 40 mm with a Visual Stability Index (VSI) of 0 or 1 in accordance with CSA A23.2-19C are permissible.
- 10) 28 mm Nominal Maximum Size of Coarse Aggregate may also be used.
- 11) The concrete mix shall satisfy the additional requirements regarding sulphate attack in accordance with CSA A23.1-24 Table 3. Cementitious materials testing is required per CSA A3004-C8; maximum expansion at 6 months shall be less than 0.05% or less than 0.10% at 1 year for S-2 exposure, and at 6 months shall be less than 0.10% for S-3 exposure. Requirements for S-1 exposure shall be determined in consultation with the Ministry. No additional requirements regarding sulphate attack are required for lower sulphate concentrations than those for S-3 class of exposure according to CSA A23.1 Table 3.
- 12) Pre-blended bagged concrete mixes shall only be used when Consented to by the Ministry. Pre-blended bagged concrete mixes may be considered where limited ready mix concrete supply is available.
- 13) The total cementitious content shall not exceed 400 kg/m<sup>3</sup>. The use of supplementary cementitious materials shall be in accordance with one of the following:
  - a) Maximum 20% Type F fly ash by mass of cementitious materials, or
  - b) Maximum 35% slag by mass of cementitious materials, or
  - c) a combination of Type F fly ash and slag, with one of these components meeting its



minimum percentage from a) or b) above, and with a combined maximum of 35% by mass of cementitious materials.

- 14) The use of 5-8% silica fume is required. In addition to the silica fume, following shall also apply:
- a) 10-15% Type F fly ash by mass of cementitious materials, or
  - b) 15-25% Slag by mass of cementitious materials, or
  - c) a combination of Type F fly ash and slag, a combination of Type F fly ash and slag, with one of these components meeting its minimum percentage from a) or b) above, and with a combined maximum of 25% by mass of cementitious materials.
- 15) The use of supplementary cementitious materials shall be in accordance with one of the following:
- a) 15-35% Type F fly ash by mass of cementitious materials, or
  - b) 25-40% Slag by mass of cementitious materials, or
  - c) a combination of Type F fly ash and slag, with one of these components meeting its minimum percentage from a) or b) above, and with a combined maximum of 40% by mass of cementitious materials.

**Commentary:** *Changes to the target slump may be Consented to by the Ministry for substructure concrete in special circumstances such as in heavily congested elements or elements with other constraints that make it difficult for concrete placement and consolidation.*

*Concrete mix with silica fume as the sole SCM has potential of deck cracking. Addition of the fly ash or slag can mitigate this issue. Concrete mix with silica fume should be avoided for late chloride exposure.*

### 8.11.2.3.2 Concrete placement

Add the following:

The deck casting sequence and the detail for construction joints shall be shown on the Plans. Typically, deck slabs shall be cast in the direction of increasing grade (uphill).

For simply supported span structures, each span shall be cast in one continuous operation unless otherwise Consented to by the Ministry.

For continuous structures, concrete shall be cast full width in stages to limit any post-construction cracking in the deck concrete to less than 0.20 mm at the surface of the structural deck. In specifying the deck pour sequence, the designer shall pay particular attention to the adverse effects of stress reversal within freshly cast concrete deck slabs.

**Commentary:** *Concrete placement temperatures are identified in the SS and DBSS and should not be specified separately by the designer without the Consent of the Ministry.*

*A deck casting sequence is required in order to minimize the potential for deck cracking due to improper concrete placement sequencing.*

Several factors limit the quantity of concrete which can be placed in one continuous operation. Special consideration shall be given if the continuous placement exceeds a volume of 200 cubic metres or if the bridge deck exceeds four lanes in width.

Structures are to be cast full width to uniformly load the superstructure and to avoid differential deflection between stringers. The positive moment regions are generally cast first followed by the negative moment areas.

The following is generally the Ministry's deck casting procedure:

**Concrete in positive-moment zones:** All concrete in these zones to be cast prior to concrete in negative-moment zones.

**Concrete in negative-moment zones:** Concrete in these zones are typically not be cast until adjacent concrete in positive- moment zones have been cast, unless cast monolithically with the positive-moment concrete as shown below in pour sequence 4.

**Concrete deck above concrete diaphragm without wearing surface:** Concrete deck above diaphragms shall be cast after diaphragm concrete has set to avoid subsidence effect.

**Figure C8.11.2.3.2**  
**Sample schematic of deck pour sequence**

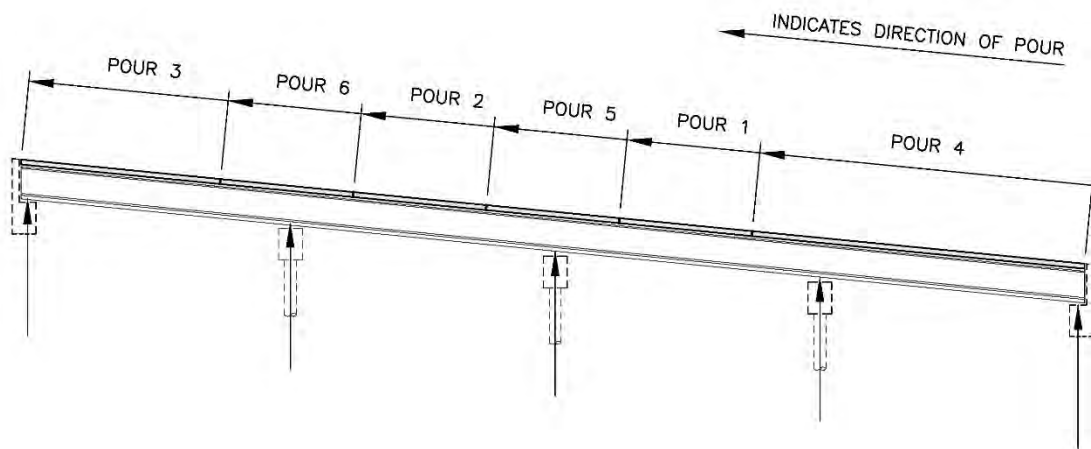

Unless higher strengths are required by the designer, deck concrete shall attain a strength of 15 MPa before parapets are placed and 25 MPa before heavy loads, such as concrete trucks, are allowed on the bridge.

Concrete placement sequence for integral abutments shall be given special consideration to reduce stresses induced by deflection of the girders. Unless otherwise Consented to by the Ministry, the full width and length of deck shall be cast prior to the end diaphragms being cast integral with the abutment.

**Commentary:** For integral abutments, techniques for reducing stresses induced by deflection of the girders may include delaying the casting of the abutments and/or the deck in the abutment area until after all other deck concrete has been cast.

### 8.11.2.3.5 Slip-form construction

Add the following:

Extruded concrete barriers shall not be used.

### 8.11.2.3.6 Finishing

Delete the entire clause and replace with the following:

The methods to be used for finishing surfaces of concrete to ensure a durable surface shall comply with the relevant SS and DBSS clauses, unless otherwise Consented to by the Ministry.

Surface finishes shall be in accordance with Table 8.11.2.3.6, unless otherwise Consented to by the Ministry, and shall be specified in the Special Provisions.

**Table 8.11.2.3.6**  
**Surface finishing requirements**

Surface	Finish	Relevant SS or DBSS clause
Surfaces submerged or buried	Class 1	211.17
Top and inside (exposed) face of parapets, curbs	Class 3	211.17
Outer face of parapets, curbs; outer edges of deck	Class 2	211.17
Abutments and retaining walls	Class 2	211.17
Piers	Class 2	211.17
Bearing seats	Steel Trowel	211.14
Top of deck	Tined <sup>(1)</sup>	413.02.02 (e)
Approach slabs	Float Finish	211.14
Sidewalks	Transverse Coarse Broom	211.14

Underside of Deck	Class 1 (or better)	211.17
Slope Pavement	Transverse Coarse Broom <sup>(2)</sup>	211.14

**Notes:**

(1) Decks to receive waterproofing membranes shall be finished in accordance with SS 419.33 or DBSS 419.33 as applicable.

(2) Exposed Aggregate finishes may be considered.

Consideration shall be given to surfaces exposed to close public view such as piers and abutments on underpasses where a Class 3 finish may be considered and underside of decks where a Class 2 finish may be preferred.

Exposed concrete surfaces of large abutments or retaining walls that are clearly visible to the public may require a special architectural finish. The selection of surface finishes shall also consider future removal of graffiti, including the application of anti-graffiti coatings.

#### 8.11.2.4 Concrete cover

Add the following:

All references to “minimum cover” shall be considered as the minimum specified cover. The tolerances specified in SS 412 and DBSS 412 shall apply to the minimum specified cover.

The soffits of deck slabs cantilevered from the exterior girder shall be considered as exposed to harsh conditions and shall have additional cover as noted in S6:19 under Table 8.5.

The cover and tolerances given in Table 8.5a below shall govern over Table 8.5 from S6:19.

Add Table 8.5a as follows:

**Table 8.5a**  
**Minimum specified concrete covers and tolerances**  
(See Clause 8.11.2.4)

Component	Reinforcement/ steel ducts	Cast-in-place concrete (mm)	Precast concrete (mm)
Top Surfaces of Bridge Decks and Approach Slabs	Reinforcing Steel	<sup>(1)</sup> +6 -0	<sup>(1)</sup> +6 -0
	Pretensioning strands	–	100 ±5
Ministry Standard Precast Box Girders	Reinforcing steel		
	- Top surfaces	–	<sup>(1)</sup> +10 -5
	- Vertical surfaces	–	40 +10 -5
	- Soffits	–	30 +10 -5
	- Inside surfaces	–	30 +10 -5
	Pretensioning strands		
	- Top surfaces	–	200 ±5
	- Vertical surfaces	–	50 ±5
	- Soffits	–	40 ±5
	- Inside surfaces	–	35 ±5
Ministry Standard Precast I-Beams	Reinforcing steel		
	- Top surfaces	–	30 +10 -5
	- Vertical surfaces	–	30 +10 -5
	- Soffits	–	30 +10 -5
	Pretensioning strands		
	- Top surfaces	–	100 ±5
	- Vertical surfaces	–	40 ±5
	- Soffits	–	40 ±5

**Notes:**

(1) For the minimum specified cover and reinforcing steel type, see Table 8.11.2.5.2 in Clause 8.11.2.5.2

**Commentary:** Additional concrete cover as specified in the notes below Table 8.5 in S6-19 are not required for the top surface of concrete decks.

The term “minimum cover” should be avoided on the Plans as it creates confusion for installers. The term “specified cover” is the preferred term and the appropriate placing tolerances would apply. For example, for the vertical reinforcing in the Ministry Standard Precast Box Girders, a “specified cover” of 40 mm with placing tolerances of +10 mm and -5 mm will provide the correct installation.

*Designers must be aware of, and account for, placing tolerances and specified cover requirements. Consideration shall be given to the cover requirements on mechanical splices.*

### **8.11.2.5 Corrosion protection for reinforcement, ducts and metallic components**

Add the following clauses:

#### **8.11.2.5.1 General**

Ends of prestressing strands shall be painted with a Ministry accepted organic zinc rich paint where the ends of stringers are incorporated into concrete diaphragms or are otherwise embedded in concrete.

Ends of prestressing strands shall be given a minimum 3 mm thick coat of thixotropic epoxy in 100 mm wide strips applied in accordance with the manufacturer's requirements where ends of stringers are not embedded in concrete. For prestressed box girders, the entire ends of the girder shall be coated.

If galvanized reinforcing steel is used, all reinforcing steel in the component shall be galvanized. Galvanized bars and uncoated bars shall not be permitted to be in contact with each other as specified in SS 412.11.03 and DBSS 412.11.03.

Precautions that are to be taken for cold-bent reinforcing steel that is to be galvanized shall include:

- increasing the minimum bend diameter to meet the requirements for epoxy coated steel as provided in SS Table 412-C
- ensuring Grade W (weldable) reinforcing is used in accordance with SS 412.11.03 and DBSS 412.11.03.

and

- stress relieving the reinforcing steel after bending and prior to galvanizing in accordance with SS 412.11.03 and DBSS 412.11.03. (Stress relieving procedures vary with the thickness of the material).
- Galvanized reinforcing bars are not to be bent after galvanizing.

**Commentary:** *Galvanized reinforcing steel and uncoated steel should not be used in combination due to the possibility of establishing a bimetallic couple between zinc and bare steel (i.e., at a break in the zinc coating or direct contact between galvanized steel and black steel bars or other dissimilar metals.*

*The designer is cautioned regarding the potential for embrittlement of reinforcing steel which is cold-bent and then galvanized. (Straight reinforcing bars are not prone to embrittlement).*

#### **8.11.2.5.2 Corrosion protection for bridge decks, parapets, curbs and approach slabs**

As a minimum, all reinforcing steel within the upper 50% of bridge decks and approach slabs including the top mat of deck reinforcing steel and any steel projecting into this zone and all reinforcing steel in cast-in-place parapets shall be protected against corrosion.

Corrosion protection for reinforcing steel shall be achieved by using corrosion resistant reinforcing and/or waterproofing membranes in accordance with the Table 8.11.2.5.2 below, unless otherwise Consented to by the Ministry.

**Table 8.11.2.5.2**  
**Corrosion protection options for top mat reinforcing steel for bridge decks, parapets, curbs and approach slabs**

Rebar type <sup>(1)</sup> for top mat of deck and approach slabs, and for the parapets and curbs	Minimum deck thickness (mm)	Specified Top Cover <sup>(1)</sup> (mm)	Where used <sup>(2)</sup>
Stainless steel	225	60 <sup>(3)</sup>	Main roads where there is no waterproofing membrane
Stainless steel	225	50	Main roads where there is also a waterproofing membrane
Low carbon/chromium to ASTM A1035 Type CS	225	70	Other roads where there is no waterproofing membrane
Low carbon/chromium to ASTM A1035 Type CS	225	50	Other roads where there is also a waterproofing membrane
Black, epoxy coated, galvanized, ASTM A1035 Type CM	225	70	Gravel roads where there is no waterproofing membrane

**Notes:**

(1) Rebar type in accordance with Clause 8.4.2.1.1.

(2) Main roads = includes all structures on all primary highways and other highways with a current AADT of 2000 or greater.

Other roads = includes all other structures.

Gravel roads = gravel roads and roads with an ADT of less than 400 vehicles.

(3) Cover may be reduced to 50 mm for MoTT Standard Bridge Parapet Barriers (2784-7)

For cable supported structures, stainless steel reinforcing shall be used in both the top and bottom mats of the deck.

For pedestrian bridges with a clear walkway width of less than 3 m, black steel reinforcing bars may be used. For pedestrian bridges of 3 m and wider, corrosion protection of deck reinforcing steel shall be in accordance with the requirements for "Other roads" in Table 8.11.2.5.2.

Other corrosion protection for reinforcing steel, including stainless-steel clad reinforcing and composite reinforcing steel (GFRP, CFRP etc.) may only be used with Consent of the Ministry.

**Commentary:** The BC numbered highway functional classification can be found at: [https://www2.gov.bc.ca/assets/gov/driving-and-transportation/transportation-infrastructure/planning/inventories/bc\\_numbered\\_hwy\\_functional\\_classes\\_map.pdf](https://www2.gov.bc.ca/assets/gov/driving-and-transportation/transportation-infrastructure/planning/inventories/bc_numbered_hwy_functional_classes_map.pdf).

Black steel is generally used for bottom mat reinforcing.

### 8.11.2.5.3 Corrosion protection for components subject to spray or surface runoff containing de-icing chemicals

Except in Ministry Service Areas 1, 2, 3, 4, 6 and 27, steel reinforcement, anchorages, and mechanical connections specified for use within 75 mm of a surface exposed to moisture containing de-icing chemicals shall use corrosion resistant material in accordance with Table 8.11.2.5.3, unless otherwise Consented to by the Ministry. This shall include the following components:

- components and surfaces under expansion joints, such as bearings and girders, ballast walls, end diaphragms, bearing seats, etc. for a horizontal distance from the joint of 1.5 x the superstructure depth.
- exposed surfaces of piers, abutments, retaining walls where buildup of snow containing de-icing chemicals in contact with the component will occur
- components on main roads adjacent to or up to 3.0 m above the pavement surface subject to spray containing de-icing chemicals.

**Commentary:** Corrosion resistant material should also be considered as follows for concrete decks with or without curbs but with open railings:

- For the underside of the deck, past the drip groove for a minimum distance of 1.0 m.
- For soffits that are level or slope inward, the portion from the exterior edge to the full soffit width.
- For girders, the exterior surface and soffit of the girder.

**Table 8.11.2.5.3**  
**Corrosion protection for components subject to de-icing chemicals**

Corrosion resistant material type <sup>(1)</sup>	Where used <sup>(2)</sup>
Stainless steel	Main roads
Low carbon/chromium ASTM A1035 Type CS	Other roads
Black, epoxy coated, galvanized, ASTM A1035 Type CM	Gravel roads

**Notes:**

(1) Rebar type in accordance with Clause 8.4.2.1.1.



(2) Main roads = includes all structures on all primary highways and also on other highways with a current AADT of 2000 or greater.

Other roads = includes all other structures.

Gravel roads = gravel roads and roads with an ADT of less than 400 vehicles.

### 8.11.2.6 Drip Grooves

Continuous drip grooves shall be formed on the underside of bridge decks and shall be detailed as shown below in Figure 8.11.2.6.

**Figure 8.11.2.6**  
**Drip groove detail**

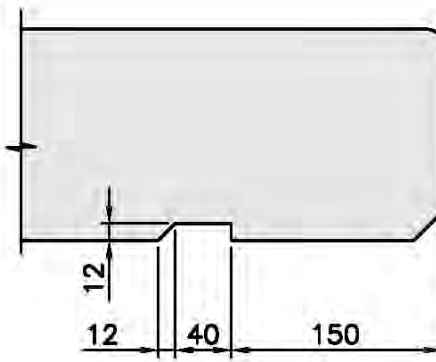

### 8.11.2.7 Waterproofing

Delete the first paragraph and replace with:

Unless otherwise Consented to by the Ministry, all bridges, other than on gravel roads, in the South Coast Region shall have a hot rubberized asphalt membrane system for waterproofing and 100 mm thick asphalt overlay on top of the bridge deck. Wick and weep drains shall be detailed at low points and points of blockages to ensure that water between asphalt and the membrane can be discharged. Water shall be discharged to avoid safety and maintenance issues such as avoiding sidewalks, pathways, traffic lanes, and bearing seats.

Buried concrete structures with a soil cover of 1000 mm or less shall receive a hot rubberized asphalt membrane system for waterproofing. Positive drainage shall be provided on the top surfaces of buried structures to avoid ponding of water.

Bridges with no waterproofing membrane located on paved roads shall be protected with an application of linseed oil or as otherwise directed by the Ministry.

## 8.12 Control of Cracking

### 8.12.1 General

Add the following:

Control joints shall extend around the entire perimeter of the traffic barrier and be evenly spaced throughout the full length of the barrier with spacing not exceeding 3 m as shown below.

**Figure 8.12.1(a)**  
**Control joint detail**

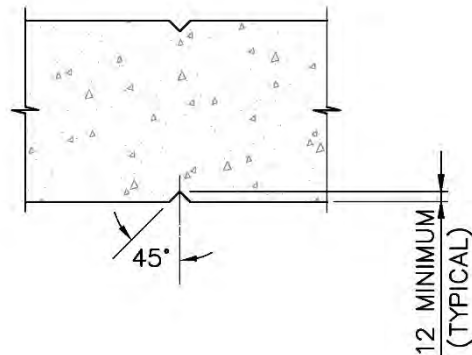

Concrete traffic barriers shall have a minimum 6 mm wide rotation joint over the supports on continuous spans as shown below.

**Figure 8.12.1(b)**  
**Rotation joint detail**

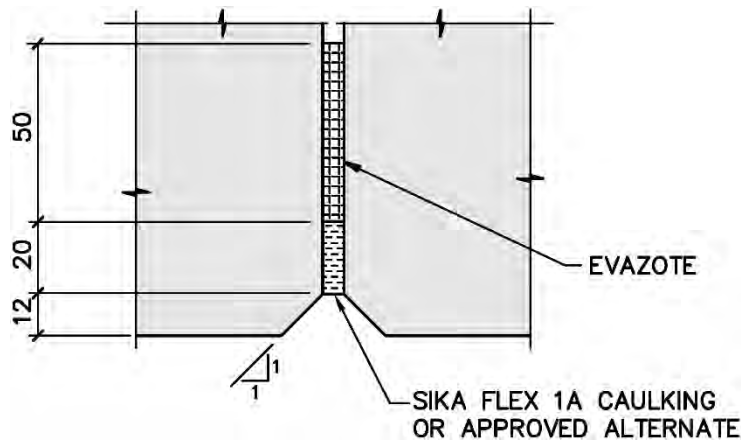

## 8.13 Deformation

### 8.13.3 Deflections and rotations

#### 8.13.3.3 Total deflection and rotation

**Commentary:** The Commentary to S6 (S6.1:19) states that long time deflection and rotation may be calculated by using the empirical multipliers given in Table C8.8 which is taken from CPCI (1996). However, Table C8.8 is not an exact copy of the table included in CPCI (1996). The original table or the table in the current edition of the CPCI Handbook (CPCI (2017)) may be used in place of the commentary.

## 8.14 Details of reinforcement and special detailing requirements

### 8.14.3 Transverse reinforcement for flexural components

Add the following:

Typical arrangements for transverse reinforcement of pier caps are shown in Figure 8.14.3.

**Figure 8.14.3**  
**Typical transverse reinforcement of**  
**pier caps (drip grooves and top surface slope not shown)**

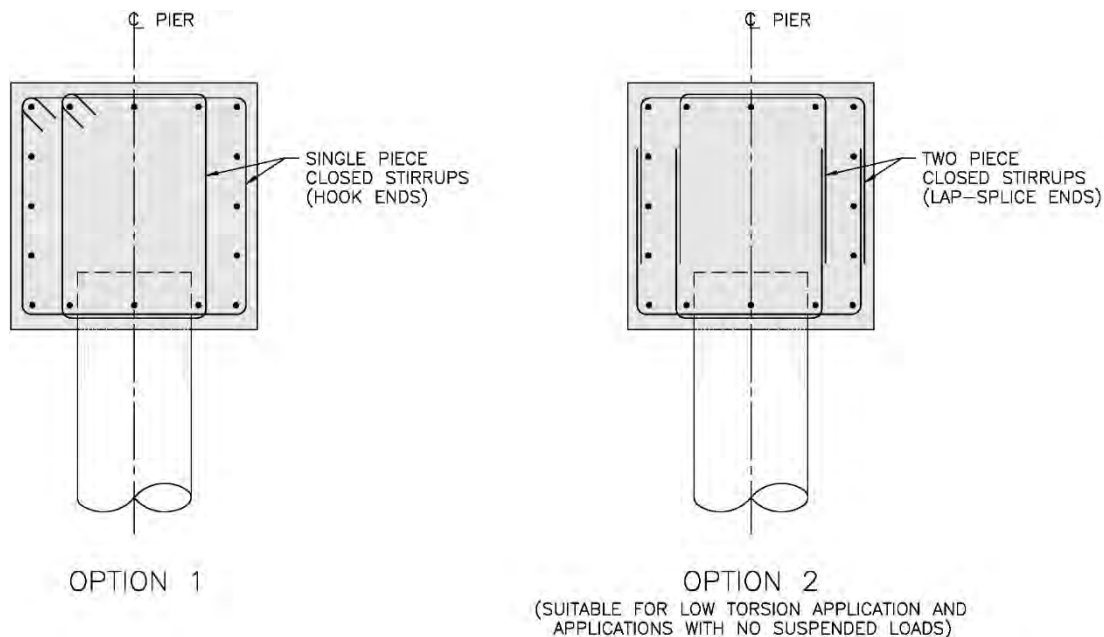

**Commentary:** The typical transverse reinforcement arrangements shown in Figure 8.14.3 alleviate problems encountered with installation of longitudinal reinforcing in situations where piles are installed slightly off alignment. These preferred arrangements facilitate placement of two longitudinal bars in

close proximity to the piles. Identical-size pairs of closed stirrups which lap one another horizontally do not provide as much tolerance for placement of the two longitudinal bars adjacent to the piles.

For diaphragms and other varying depth members, closed stirrups formed from two-piece lap-spliced U-stirrups or U-stirrups with lapped L splice bars as shown in Supplement Figure 8.20.7.1 shall be used (low torsion applications and applications with no suspended loads).

**Commentary:** Problems are encountered with stirrup sizes in diaphragms when stirrups are either too long or too short depending on the final depth of the haunches. The method of using two-piece U-stirrups of suitable depth allows for minor adjustments and alleviates problems of proper field fit-up when accommodating variable depth of diaphragms.

## 8.15 Development and splices

### 8.15.7 Combination development length

**Commentary:** Figure 8.15.7 below illustrates how the development length,  $l_d$ , may consist of a combination of the equivalent embedment length of a hook or mechanical anchorage plus additional embedment length of the reinforcement measured from the point of tangency of the hook.

**Figure 8.15.7**  
Combination development length

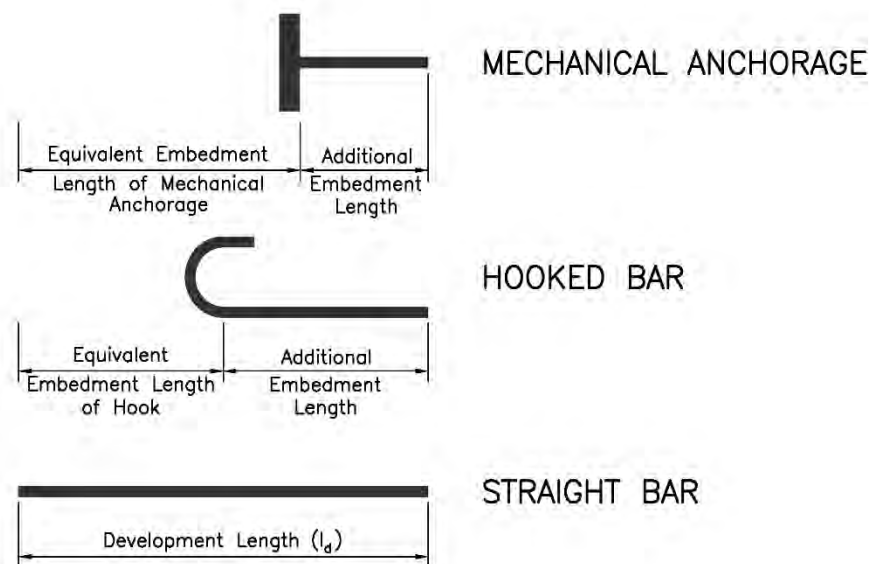

### 8.15.10 Splicing of reinforcement

#### 8.15.10.1 Lap splices

Add the following:

All splices that are critical to the structure shall be indicated on the Plans.

Splicing of transverse reinforcing bars in bridge decks shall be avoided if possible. If such splices are necessary, their location shall be indicated on the Plans.

### **8.15.10.2 Welded splices**

Add the following:

The use of welding to splice reinforcement is not permitted unless Consented to by the Ministry.

## **8.16 Anchorage zone reinforcement**

### **8.16.7 Anchorage of attachments**

Add the following:

Anchor dowel details for the Ministry standard prestressed concrete box stringers shall be designed based on the details similar to those shown in the Ministry Standards and Procedures Manual Volume 3, Ministry Standard Drawings 2978-1 to 2978-24 (latest revision) and the standard reference details for Standard Twin Cell Box Stringers. Similar details may be used, as appropriate, for Ministry Standard Single Cell Box Stringers, Drawing D205.

## **8.18 Special provisions for deck slabs**

Add the following:

Bridge deck heating systems are not permitted.

***Commentary:** Heating of bridge decks in British Columbia has been problematic. Its use has therefore been discontinued.*

### **8.18.1 Applicability**

Add the following:

The design of partial and full depth precast panel decks shall be completed in accordance with Cl. 8.18.3.4 and Cl. 8.18.3.5 of the Supplement except that 8.18.3.4.2 d) only applies when the deck is proportioned with the empirical design method.

### **8.18.2 Minimum slab thickness**

Delete the last sentence and replace with the following:

The slab thickness shall not be less than 225 mm.

#### **8.18.2.4 Allowance for wear**

Delete this clause.

## 8.18.3 Empirical design method

### 8.18.3.4 Cast-in-place deck slabs on precast panels

#### 8.18.3.4.3 Cast-in-place topping

*Commentary:* The Ministry has observed cracks at the ends of short discontinuous reinforcement placed above transverse joints in decks with partial depth panels. Use of such details should be carefully considered by the designer in terms of crack control.

### 8.18.3.5 Full-depth precast panels

Add the following:

Full-depth precast panels may only be used on numbered highways when Consented to by the Ministry.

Delete the first sentence and replace with the following:

Design of full-depth precast panels shall satisfy the following conditions in addition to those of Clause 8.18.3.2 and, as applicable, Clause 8.18.3.3:

Delete Item (c) and replace with the following:

- c) at their transverse joints, the panels are joined together by grouted reinforced shear keys and are longitudinally post-tensioned with a minimum effective prestress of 1.7 MPa. The post-tensioning system shall be fully grouted. The transverse joints shall be of a female to female type. Tongue and groove type shear keys and butt joints shall not be used. The shear key shall be detailed to allow for the panel reinforcing to be lapped with hooked ends with reinforcing placed parallel to the shear key. Figure 8.18.3.5(a) details the requirements for minimum shear key size.

**Figure 8.18.3.5a)**  
**Full depth precast panel shear key**

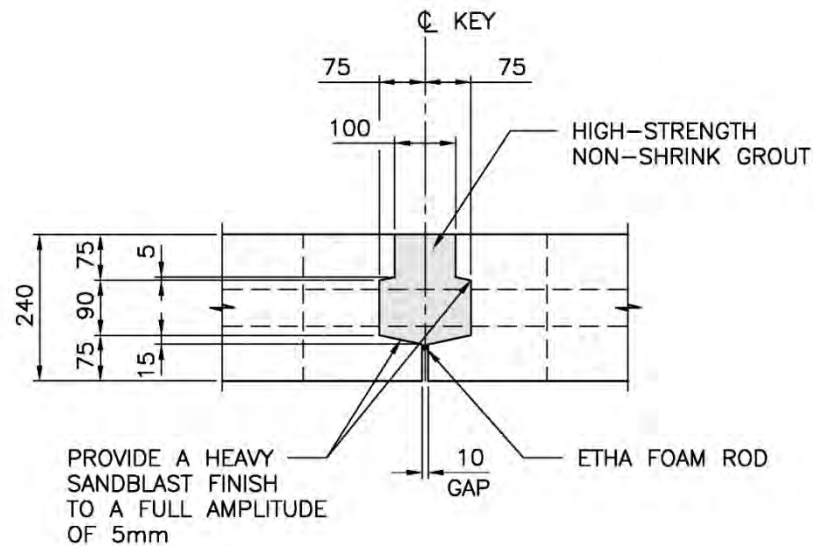

Alternatively, reinforced concrete shear keys may be used without post-tensioning where Consented to by the Ministry. The shear key design shall account for all force transfer effects through the shear keys. Figures 8.18.3.5(b) and 8.18.3.5(c) give examples for reinforced shear keys.

**Figure 8.18.3.5(b)**  
**Full depth precast panel with reinforced shear key over deck support member**

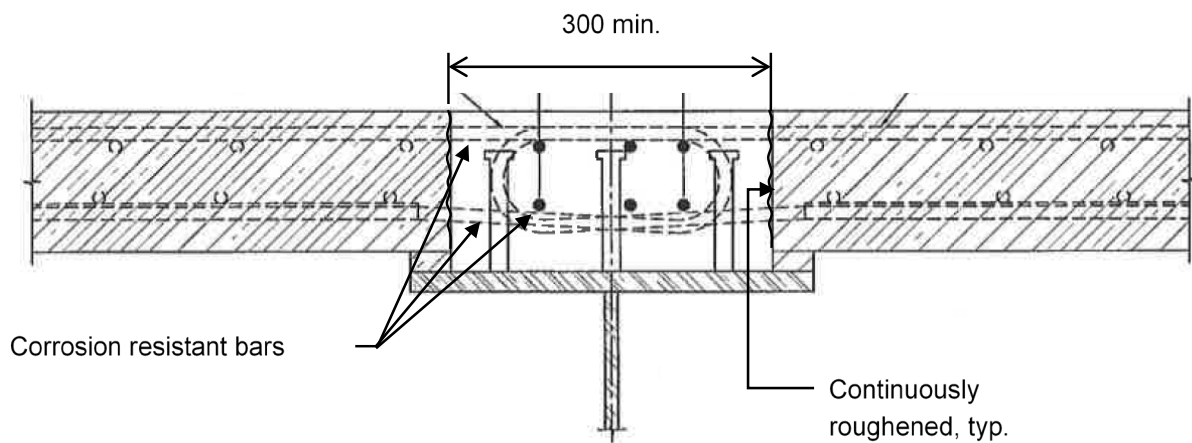

**Figure 8.18.3.5(c)**  
**Full depth precast panel with reinforced suspended shear key**

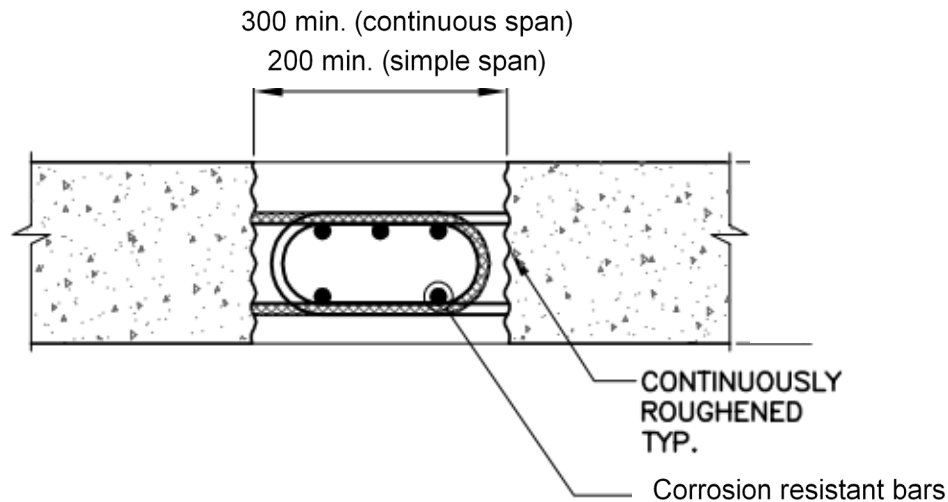

Add the following additional items:

- h) a minimum specified gap of 25 mm for grout shall be provided under the panels above the supporting beams, including any splice plates. The gap for grout may be omitted for LVR bridges when Consented to by the Ministry.
- i) the deck slab comprised of full-depth precast panels shall be fully composite with the supporting beams.
- j) when cast-in-place concrete parapets are they shall be continuous across the transverse joints except in the negative moment regions of the supporting beams. The parapets shall be placed after the deck panels are placed and fully grouted.
- k) the deck shall have a waterproofing membrane with a 100 mm thick asphalt wearing surface unless otherwise Consented to by the Ministry. Bare precast concrete decks may be used on low volume road bridges and gravel roads.
- l) stud connectors shall be in accordance with Clause 10.11.8.3.3.

**Commentary:** Shear keys between precast deck panels may also consist of reinforced concrete joints or, when Consented to by the Ministry, of ultra-high performance fibre-reinforced concrete (UHPC) In these cases adequate force transfer through the joints and reinforcing bar overlap need to be assured.

Further information on UHPFRC shear keys and joints as well as guidance to splice and development lengths can be found in Annex A8.1 in S6:19.

Confinement of stud clusters may be required to obtain the required shear connector strength.



## 8.18.4 Diaphragms

Add the following sentence to the end of the first paragraph:

Steel diaphragms for concrete girders shall be hot-dipped galvanized and detailed similar to Supplement Figure 8.20.7.3. For monolithic cast-in-place concrete end diaphragms and intermediate diaphragms, consideration shall be given to additional deck reinforcing over the diaphragms to withstand negative moment demands. Refer to Clause 8.20.7 for specific guidance regarding design of concrete diaphragms for concrete girders.

## 8.19 Composite construction

### 8.19.1 General

Add the following:

Ministry standard prestressed concrete box girders with a concrete overlay wearing surface with no interface shear-friction reinforcement shall be designed as non-composite, unless otherwise Consented to by the Ministry. For non-composite design, the placement of a concrete overlay wearing surface on top of box girders shall be considered as an additional dead load and shall not be assumed to contribute to any composite properties under live loads.

Composite prestressed concrete box girders shall achieve composite action using interface shear-friction reinforcement between the box girder and the composite topping.

See Clause 8.21 for further details regarding concrete box girders.

### 8.19.3 Shear

Add the following:

Shear reinforcement in prestressed I-beams shall extend 125 mm above the top of the beam. When the haunch height exceeds 75 mm, additional shear reinforcement (e.g. shear ties matching the spacing of stirrups in the I-beams) and additional longitudinal reinforcing at the haunch corners shall be provided as shown in Supplement Figure 8.19.3 (a).

Additional shear reinforcement and longitudinal reinforcing at the haunch corners shall also be provided above steel girders, as shown in Figure 8.19.3 (b), where haunch heights exceed 75 mm.

**Figure 8.19.3 (a)**  
**Additional reinforcement for haunches over 75 mm high (conceptual)**

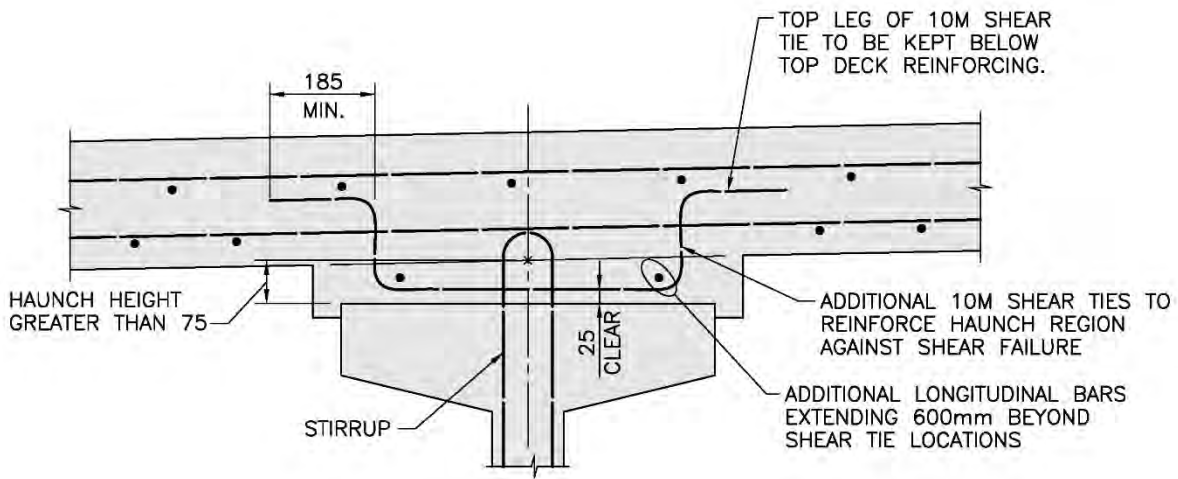

**Figure 8.19.3 (b)**

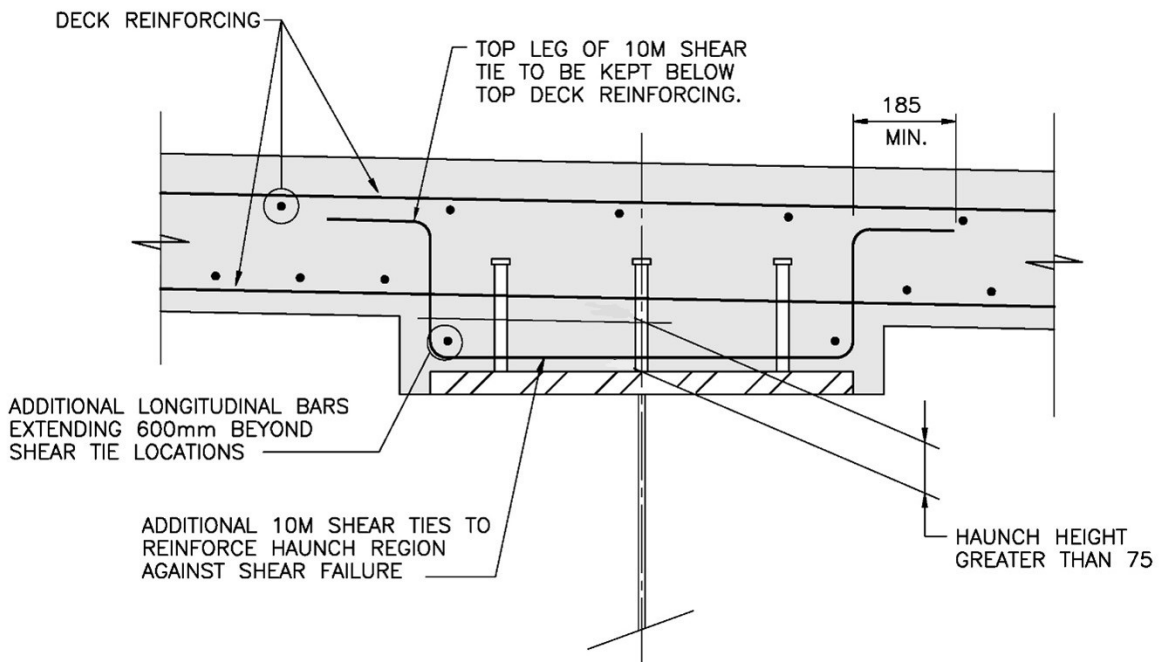

**Additional reinforcement for haunches over 75 mm high (conceptual)**

**Commentary:** The examples in Figure 8.19.3 (a) and (b) show haunch reinforcement on a conceptual level. The reinforcing requirements for these haunches should be checked during design and the reinforcement in the haunches adjusted as required. Particular attention should be given to situations with deep haunches where the stirrups or shear studs may not protrude into the deck beyond the bottom deck slab reinforcement.

## 8.20 Concrete girders

### 8.20.1 General

Add the following:

Prestressed concrete I-girder and box girder skews over 30° shall be avoided where possible. Where skews over 30° are used, sharp corners at ends of girders shall be chamfered as a precaution against breakage.

Box girders shall be skewed in increments of 5°, unless otherwise Consented to by the Ministry.

### 8.20.3 Flange Thickness for T and Box Girders

#### 8.20.3.2 Bottom Flange

Add the following:

The cross-section dimensions of the Ministry Standard Twin Cell Box Stringers shown on Drawings 2978-1 to 2978-24 (latest revision) shall be considered acceptable for use on Ministry projects.

**Commentary:** The bottom flange thickness of Ministry standard prestressed concrete box stringers does not comply with the minimum code requirement of 100 mm. No rationale is given in the Code or the Commentary for this minimum requirement.

The current series of standard twin cell boxes have been in use since the late 1970's and have performed extremely well over the years. The increase in cost of fabrication and transportation necessary to update to the cover requirements of S6:19 is not considered to be warranted.

### 8.20.6 Post-Tensioning Tendons

Add the following:

Unbonded post-tensioning tendons shall not be used.

**Commentary:** Unbonded tendons have experienced numerous corrosion incidents due to inadequacies in corrosion protection systems, improper installation, or environmental exposure before, during and after construction.

### 8.20.7 Diaphragms

Delete clause and replace with the following:

Concrete diaphragms shall be provided at abutments and piers. The diaphragms shall be proportioned to support the deck, to transfer loads to the supports and to allow for the future jacking of the girders. Abutment and pier diaphragms shall be oriented parallel to the bridge skew and shall have a minimum thickness of 350 mm. Additional reinforcing shall be placed between longitudinal temperature reinforcement to account for negative moment effects. The minimum added reinforcing shall be 15M bars and shall extend for a distance  $S/2$  into the deck slab from the edge of the diaphragm where 'S' is the c/c of stringers. The bars shall have a standard hook at the diaphragm end. Where intermediate concrete diaphragms support the slab, bars shall be added between the longitudinal reinforcing. The bars shall be 15M and be the same bar type as the reinforcing steel in the top mat of the deck and the length shall equal to 'S.'

A typical tie arrangement for intermediate and end diaphragms is shown in Figure 8.20.7.1 below.

**Figure 8.20.7.1**  
**Typical diaphragm tie arrangement**

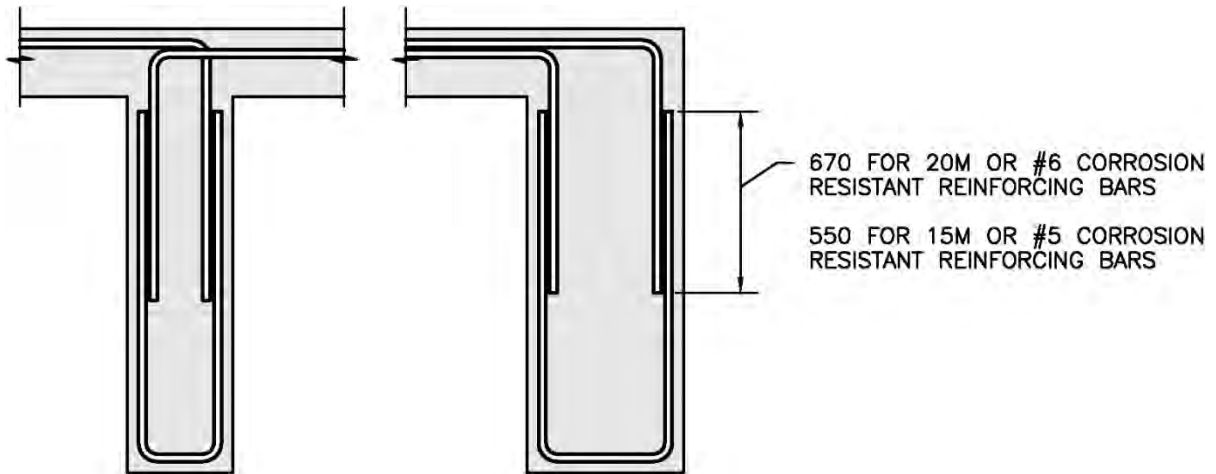

Diaphragms shall be detailed to provide access for maintenance inspection, as generally outlined in Figure 8.20.7.2 below.

**Figure 8.20.7.2**  
**Typical concrete diaphragm arrangement**

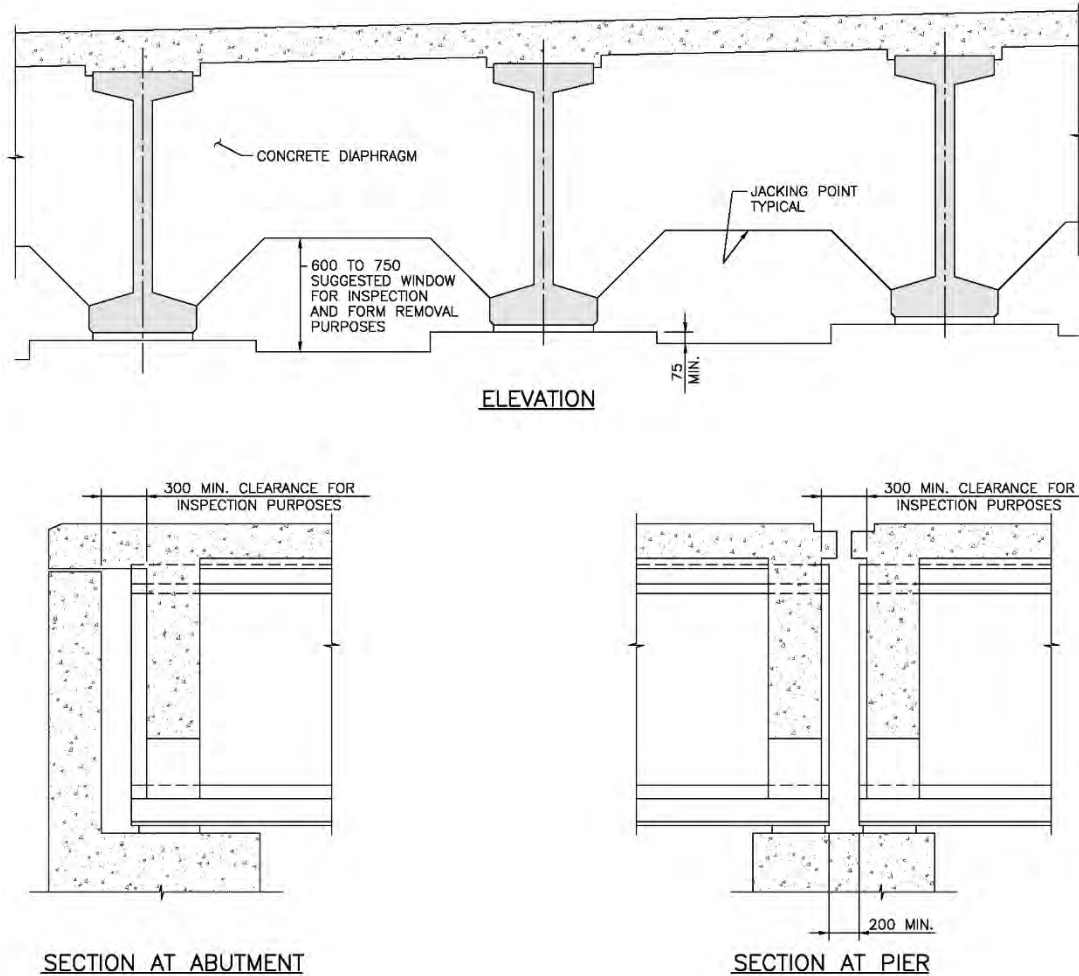

The hole size for abutment and pier diaphragm reinforcing which passes through the ends of prestressed girders should be 2.5 times the bar diameter.

Unless Consented to by the Ministry, the designer shall provide intermediate diaphragms to improve load distribution and for stability during construction and future rehabilitation. The diaphragms shall be galvanized steel framing with details similar to those in Figure 8.20.7.3 unless analysis dictates the use of a concrete intermediate diaphragm.

**Figure 8.20.7.3**  
**Typical steel diaphragm arrangement**

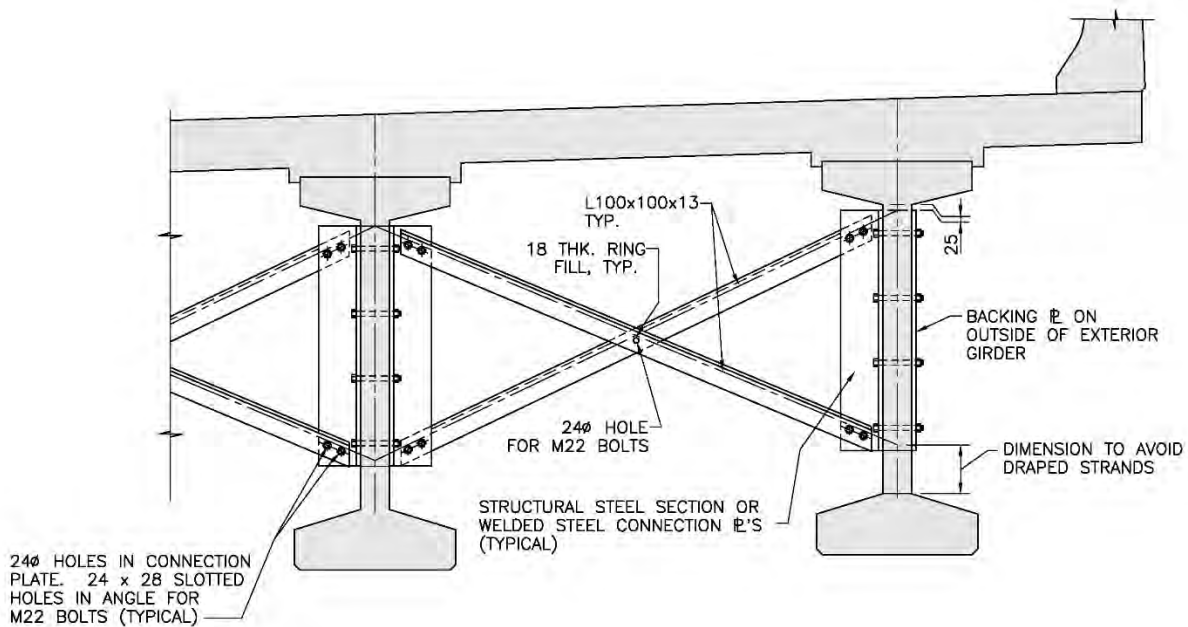

## 8.21 Multi-beam decks

Add the following:

The shear key and reinforcement details shown on Ministry Standard Twin Cell Concrete Box Stringer, Standard Drawings 2978-1 to 2978-24 (latest revision) shall be considered as an approved means for live load shear transfer between multi-beam units in accordance with Clause 8.21(c) of S6:19.

**Commentary:** Ministry standard box stringers less than 20 m in length without lateral post-tensioning have performed well (no longitudinal cracks or leaks) since they were first introduced in the late 1970's. According to site investigations completed by the Ministry on multi-beam decks with asphalt overlay where transverse post-tensioning was not used, no longitudinal cracking of the asphalt overlay was observed over the shear key areas. The majority of the non-composite box spans investigated were less than 20 m spans.

Standard box stringer bridges up to 30 m may also be used without lateral post-tensioning, provided explicit analysis indicates that the shear key has sufficient live load shear transfer capacity.

In most cases, a composite or non-composite concrete overlay is applied on twin or single cell box beams to provide a wearing surface. The specified and minimum thickness of a reinforced concrete overlay must consider the nominal maximum concrete aggregate size and bar clearance and spacing requirements. Where specified as an alternative to a concrete overlay, or as otherwise Consented to by the Ministry, the top surfaces may be protected with a waterproofing membrane selected from the Ministry's Recognized Products List, and applied in accordance with the manufacturer's instructions with an asphalt overlay of 100 mm placed in two lifts of 50 mm.

**Commentary:** Figures 8.21 (a) and 8.21 (b) are suggested means of achieving composite action between the structural beam and the composite reinforced concrete deck slab.

**Figure 8.21 (a)**  
**Twin cell box beam composite deck slab connection detail**

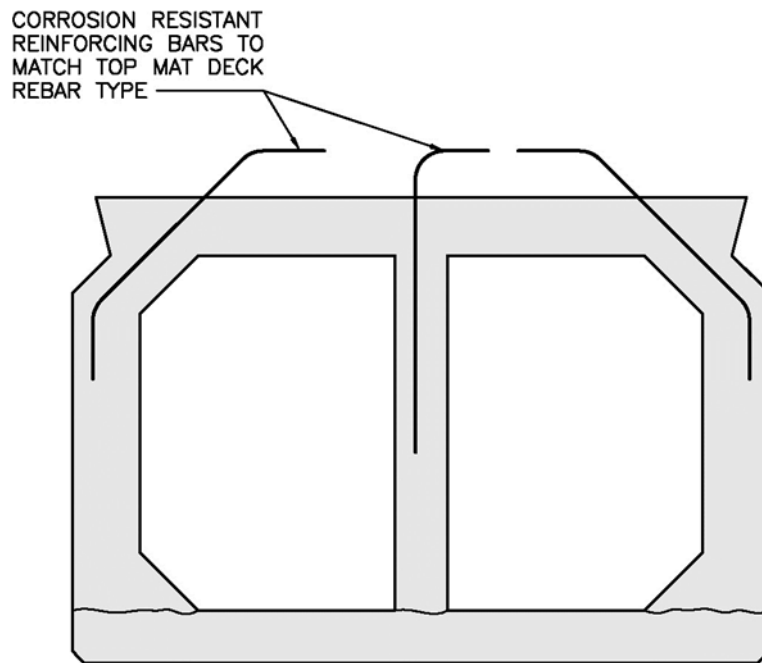

**Figure 8.21 (b)**  
**Single cell box beam composite slab connection detail**

CORROSION RESISTANT  
REINFORCING BARS TO  
MATCH TOP MAT DECK  
REBAR TYPE

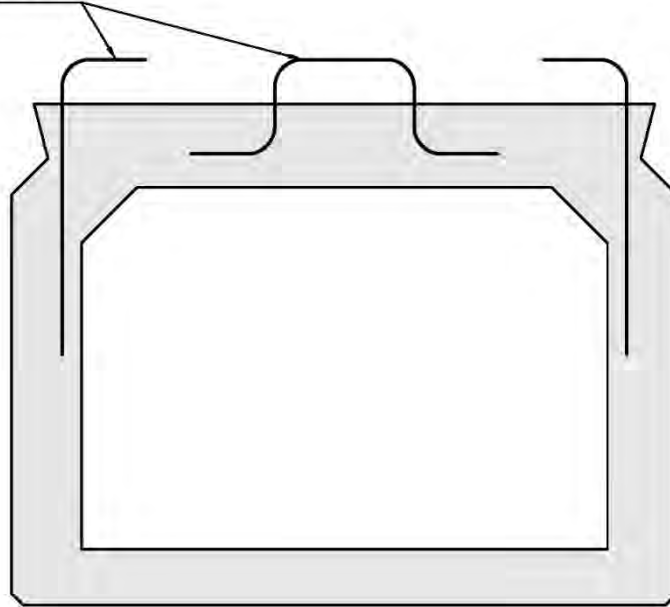

## **ANNEX A8.1 Fibre-reinforced concrete (FRC)**

### **A8.1.1 General**

Add the following:

FRC shall only be used when Consented to by the Ministry.