

- 12.4 Barriers..... 2
  - 12.4.1 General..... 2
  - 12.4.2 Barrier joints ..... 2
  - 12.4.3 Traffic barriers..... 3
    - 12.4.3.2 Test level ..... 3
      - 12.4.3.2.1 General..... 3
      - 12.4.3.2.5 Test level for barriers on low volume roads ..... 7
    - 12.4.3.3 Geometry and end treatment details ..... 7
    - 12.4.3.4 Crash test requirements ..... 8
      - 12.4.3.4.6 Zone of Intrusion..... 8
        - 12.4.3.4.6.1 General..... 8
    - 12.4.3.5 Anchorages ..... 8
  - 12.4.4 Pedestrian barriers..... 8
    - 12.4.4.1 General..... 8
    - 12.4.4.2 Geometry ..... 8
  - 12.4.5 Bicycle barriers..... 8
    - 12.4.5.1 General..... 8
    - 12.4.5.2 Geometry ..... 9
  - 12.4.6 Combination barriers ..... 9
    - 12.4.6.1.a Configuration of combination barriers ..... 9
    - 12.4.6.1.b Pedestrian combination barriers ..... 9
    - 12.4.6.1.c Bicycle combination barriers..... 11
    - 12.4.6.2 Geometry ..... 12

## 12.4 Barriers

### 12.4.1 General

**Commentary:** The CHBDC provides detailed coverage of the “warrants” for a bridge traffic or combination barrier. Using site-specific factors (i.e.: traffic volume, bridge geometry, etc.), an appropriate barrier performance, or “test level” can be analytically determined using the CHBDC methodology. In general, the Ministry’s Supplement to the CHBDC requires no changes to this approach.

However, the CHBDC provides only limited guidance on the design of a bridge traffic or combination barrier. This guidance includes a minimum barrier height requirement and specifies that barrier adequacy shall be determined from crash tests. Specific barrier design requirements are left to individual jurisdictions to establish. Hence, the content of this chapter of the Ministry’s Supplement focuses on bridge barrier design and detailing.

The CHBDC identifies additional factors to be considered in the appraisal of a barrier. These factors are further considered and supplemented as follows:

**Deck Drainage:** To facilitate deck drainage, some recent projects have incorporated a large drain opening (scuppers) in the barrier face to channel water off of the deck and into an externally mounted discharge pipe. Note that a large drainage opening is already approved for use in roadside applications, as per the Ministry’s Precast Concrete Drainage Barrier (SP941-01.02.05). Such large openings can present a hazard due to snagging of a vehicle’s wheel during impact. The use of a large drainage opening in a bridge traffic or combination barrier shall be avoided where possible. Use of scuppers requires the Consent of the Ministry. (See Supplement Section 1.8.2.3.3.)

**Electrical Conduits and Junction Boxes:** Concrete bridge and combination barriers can serve as a convenient location for running electrical conduit over the bridge length. The size and number of conduits should be limited such that their presence does not have an adverse effect on the crash performance of the barrier. Criteria are provided in Supplement Section 1.7.3.2. The conduit(s) should be located at the base of the barrier, within the rebar cage. The junction boxes to service the conduit should be located in the rear (non-impact) face of the barrier.

**Further Barrier Reference:** For expanded detail on all bridge barrier topics, a recent and relevant Canadian reference document is the Guide to Bridge Traffic and Combination Barriers (2010, Transportation Association of Canada).

### 12.4.2 Barrier joints

Add the following:

Barrier joint openings exceeding 100 mm shall be protected by sliding steel plates. All steelwork shall be hot-dipped galvanized in accordance with ASTM A 123M.

**Commentary:** Barrier joints and the ends of a barrier present a load path discontinuity resulting in a shortened zone for impact load dispersal to the bridge deck. Supplemental barrier anchorage and deck reinforcing is sometimes required in these end zones. Openings in barriers pose a catching and snagging hazard to vehicles.

## 12.4.3 Traffic barriers

### 12.4.3.2 Test level

#### 12.4.3.2.1 General

Add the following:

The following bridge traffic barrier “reference concepts” have been accepted by the Ministry for use on highway bridges in B.C. Other bridge traffic barrier concepts may be considered but require prior Consent.

All bridge barrier design shall meet the CHBDC requirements for crash testing. Each of the listed “reference concepts” is known to have met the CHBDC requirements for crash testing. Jurisdictional usage for each listed “reference concept” is included. The Design Engineer shall confirm the applicability of the of the “reference concept” with respect to crash testing, usage and detailing. The test level identified in the table below are based upon testing to NCHRP 350.

#### **TL-1 W-Beam**

**Commentary:** Details based on USDA Forest Service W-Beam Bridge Rail.

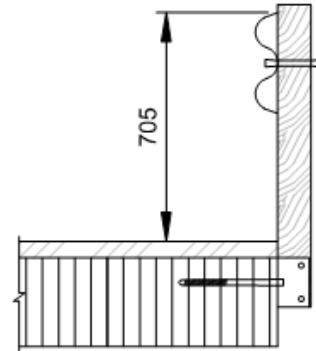

#### **TL-2 Thrie Beam (Side Mounted)**

**Commentary:** Side mounted details based on Oregon Standard Drawing BR233.

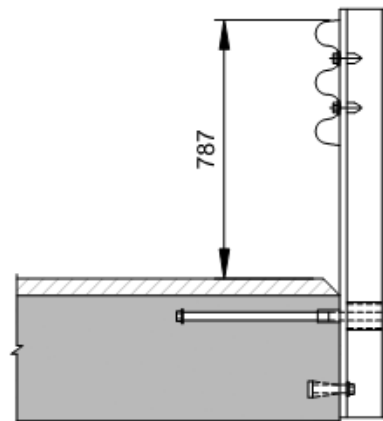

**TL-2 Thrie Beam  
(Top Mounted)**

**Commentary:** Top mounted details based on Alberta Standard Drawing S-1652-00.

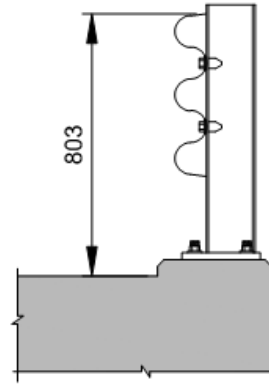

**TL-2 Two Rails  
(Side Mounted)**

**Commentary:** Side mounted details based on California Type 115 Bridge Rail.

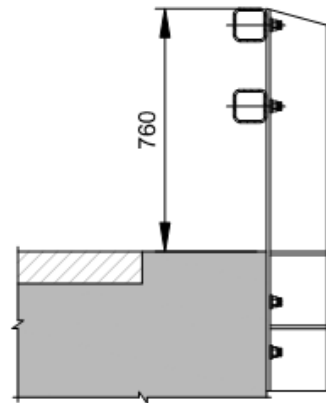

**TL-2 Two Rails  
(Top Mounted)**

**Commentary:** Top mounted system based on California Type 115 Bridge Rail, modified for top mounted anchorage. Modified anchorage to be designed in accordance with Clause 12.4.3.5 in the CHBDC.

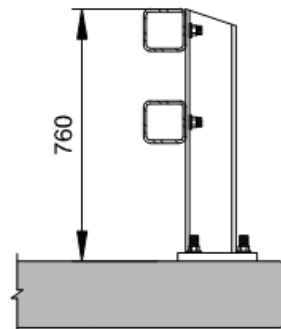

**TL-4 "F" Shape**  
(Cast-in-Place Concrete)

See the Ministry's Standard Bridge Parapet (2874-1) for detailing.

**Commentary:** Similar systems are used widely in jurisdictions across North America.

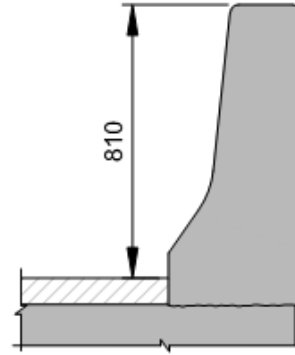

**TL-4 "F" Shape**  
(Precast Concrete, Bolt-Down)

**Commentary:** The Ministry has developed drawings for this "F" Shape barrier system and completed load testing of the anchorage details in the barrier. The anchorage testing confirmed that the CHBDC requirements for anchorage are met. As such, this barrier system is considered acceptable for use when Consented to by the Ministry. When Consented to by the Ministry, these conceptual drawings will be provided by the Ministry, and the designer will need to determine the appropriate connection details to the superstructure.

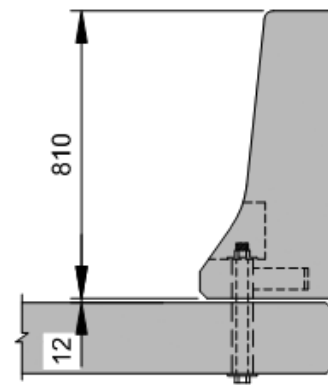

**TL-4 Double Tube on Curb**

**Commentary:** Details based on Alberta Standard Drawing S-1642-00. Alternate details in Oregon Standard Drawing BR206.

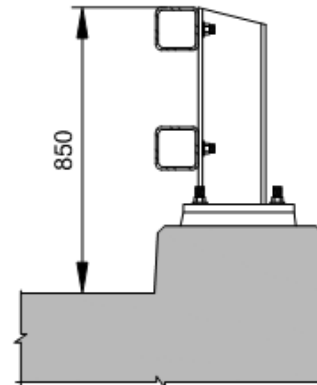

**TL-4 Constant Slope**

**Commentary:** Details based on Alberta Standard Drawing S-1650-00. Alternate details in California Type 732 Bridge Rail and Texas SSTR Bridge Rail.

A taller 1070 version of this barrier is approved for TL-5 based on the T80SS Bridge Rail used in Texas.

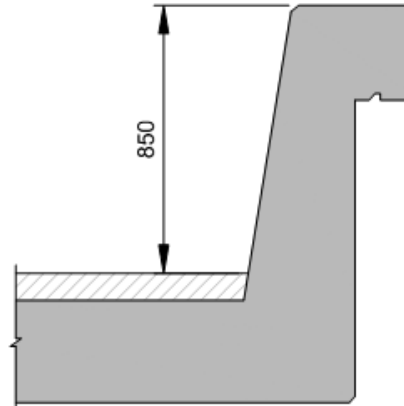
**TL-4 Vertical Face\***

**Commentary:** Details based on the Texas T221 Bridge Rail.

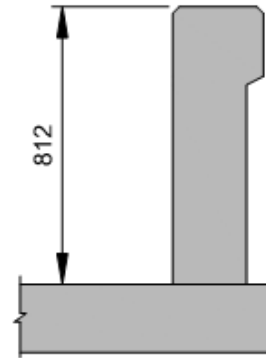
**TL-5 "F" Shape**

This is an extended version of the Ministry's Standard Bridge Parapet (2874-1).

Barrier, anchorage and deck reinforcing shall be increased in proportion to the loads listed in Table 3.8 of the CHBDC.

**Commentary:** This barrier also meets the height requirements for a pedestrian barrier.

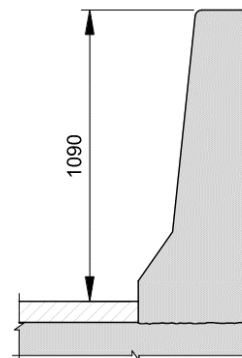

**Commentary:** Resources for further information for both the noted reference concepts and other barrier concepts include:

- *Guide to Bridge Traffic and Combination Barriers (2010)*, Transportation Association of Canada
- *TF13 Guide to Bridge Railing Systems*, (on-going project), Task Force 13 (<https://tf13.org/Guides/bridgeRailGuide/>)
- *Roadside Safety Pooled Fund* (on-going project) <https://www.roadsidepooledfund.org/>
- *Standard drawings published on provincial and state web sites*

### 12.4.3.2.5 Test level for barriers on low volume roads

Delete and replace with the following:

- TL-1 barrier systems may be used on bridges that meet all of the following:
- are classified as a Ministry Low Volume Road Structure,
- have a maximum roadway width of 8.6 m,
- have a maximum deck height above ground or water surface of 5.0 m,
- have a maximum design speed of 80 km/h combined with a maximum ADT of 100 or a maximum design speed of 50 km/h combined with a maximum ADT of 400.

For other bridges that meet the Ministry definition of a Low Volume Road Structure, Test Level 2, 4, or 5, determined in accordance with Clauses 12.4.3.2.3 and 12.4.3.2.4, shall be used unless alternative test levels are Consented to by the Ministry.

Barrier anchorage loads for Test Level 1 shall be determined in accordance with Clause 12.4.3.5. Barrier anchorage loads specified for Test Level 1 in Table 3.7 may be reduced by 20%.

**Commentary:** See CL. 1.3.3 of this Supplement for the Ministry's definition of a Low Volume Road Structure.

### 12.4.3.3 Geometry and end treatment details

Delete the third paragraph and replace with:

Protected sidewalks, bicycle and multi-use pathways shall be separated from traffic by a barrier or guide rail. For design speeds  $\leq 60$  km/h, a raised curb may be used with the curb having a face height of 200 mm and a face slope steeper than one horizontal to three vertical.

Add the following:

Traffic barriers shall be constructed such they are oriented perpendicular to the deck surface. The minimum height of barrier shall be determined for initial construction without consideration of future overlay.

**Commentary:** Traffic barriers are constructed perpendicular to the deck surface in order that the roadway face of the barrier remains correctly oriented to withstand vehicle impacts which may be inclined due to deck crossfall. This also avoids discontinuities in the barrier faces at bridge ends where parapets meet transition barriers.

Consideration should be given to potential for overdriving of the posted speed limit such as where the bridge near a change in speed limit, near sharp curves or at the base of a downhill grade.

## 12.4.3.4 Crash test requirements

### 12.4.3.4.6 Zone of Intrusion

#### 12.4.3.4.6.1 General

**Commentary:** While still a relatively new topic, further information and delineation of the Zone of Intrusion limits for different test levels can be found here: [Zone of Intrusion and Concrete Barrier Countermeasures \(2010, Stephen Hobbs, Annual Conference of the Transportation Association of Canada\)](#)

### 12.4.3.5 Anchorages

**Commentary:** Note that a live load factor of 1.7 shall be applied to the barrier loads specified in Clause 3.8.8.

## 12.4.4 Pedestrian barriers

### 12.4.4.1 General

Add the following:

The Ministry's Standard steel sidewalk fence concept shall be used (Standard Drawing 2891-1). The standard steel sidewalk fence shall extend a minimum of three (3) metres beyond the back of ballast wall at bridge abutments or extend a minimum of three (3) metres beyond the ends of return walls, as appropriate.

Debris and/or safety fence shall be installed when directed by the Ministry.

**Commentary:** The debris or safety fencing should be considered in urban areas for bridges over roadways, or bridges that cross railways to reduce the risk of objects falling from the bridge.

### 12.4.4.2 Geometry

Pedestrian barriers shall be constructed such that they are oriented plumb.

## 12.4.5 Bicycle barriers

### 12.4.5.1 General

Add the following:

The Ministry Standard steel bicycle fence concept shall be used (refer to Standard Drawing 2891-2). The standard steel bicycle fence shall extend a minimum of three (3) metres beyond the back of ballast wall at bridge abutments or extend a minimum of three (3) metres beyond the ends of return walls, as appropriate.



### 12.4.5.2 Geometry

Add the following:

Bicycle barriers shall be constructed such that they are oriented plumb.

**Commentary:** *Alternatives to the Ministry's Standard steel sidewalk or bicycle fence may be considered when debris being thrown from the bridge or people climbing the fence are identified as site-specific issues. Jurisdictions with facilities under Ministry structures, such as railways, may have requirements for protective screening that include height of screen, size of openings and length.*

### 12.4.6 Combination barriers

#### 12.4.6.1.a Configuration of combination barriers

The configuration of bridge traffic and combination barriers depends on the roadway type and the makeup of its users. In general, the bridge barrier design shall match one of the three following configurations, each described in the appended illustrations.

##### Configuration #1 - Bridge with No Sidewalk

##### Configuration #2 - Bridge with Raised Sidewalk

##### Configuration #3 - Bridge with Sidewalk Separated by a Barrier

**Commentary:** *For sides of bridges where there is no sidewalk, Combination Barriers are installed at the outside of the bridge for the safety and protection of pedestrian and/or bicycle traffic on the bridge deck.*

*For bridges with sidewalk(s), it is left to the Design Engineer to determine the most suitable type of separation based on anticipated traffic volumes and details of the crossing. In general, concrete parapet type barriers are used to separate the roadway from the sidewalk(s). The sidewalk face of the barrier shall have a smooth surface without snag points.*

*The installation of Combination Barriers is an additional cost item for bridges having no provision for sidewalks. In remote areas, where pedestrian and bicycle traffic is minimal, Traffic Barriers may possibly be used in lieu of Combination Barriers.*

#### 12.4.6.1.b Pedestrian combination barriers

The following pedestrian combination barrier "reference concepts" have been accepted by the Ministry for use on highway bridges in B.C. Other pedestrian combination barrier concepts may be considered but require prior Consent of the Ministry.

All pedestrian combination barrier designs shall meet the CHBDC requirements for crash testing. Each of the listed "reference concepts" is known to have met the CHBDC requirements for crash testing. Jurisdictional usage for each listed "reference concept" is included. The Design Engineer shall confirm the applicability of the of the "reference concept" with respect to crash testing, usage and detailing.

**TL-4 “F” Shape with Pedestrian Railing**

See the Ministry’s Standard Bridge Parapet (2874-1) for barrier detail.

See the Ministry’s Standard Bridge Parapet Steel Railing (2785-2) for railing detail.

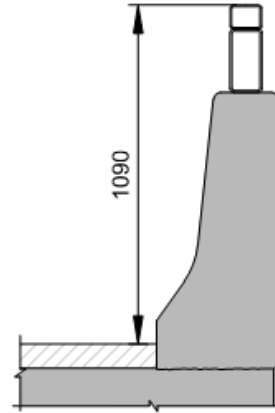
**TL-4 “Tall F” or TL-5 “F” Shape**

This is an extended version of the Ministry’s Standard Bridge Parapet (2874-1).

**Commentary:** The Ministry’s TL-5 “F” Shape inherently provides pedestrian-height protection. The barrier can be detailed for TL-4 loading, as required.

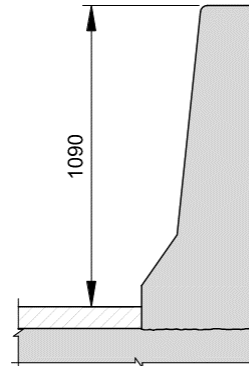
**TL-4 3-Tube on Curb**

**Commentary:** Details based on Oregon Standard Drawing BR208.

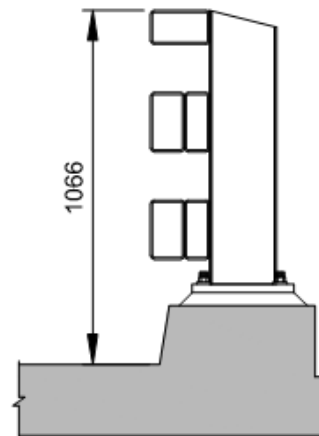

### 12.4.6.1.c Bicycle combination barriers

The following bicycle combination barrier “reference concepts” have been accepted by the Ministry for use on highway bridges in B.C. Other bicycle combination barrier concepts may be considered but require prior Consent of the Ministry.

All bicycle combination barrier designs shall meet the CHBDC requirements for crash testing. Each of the listed “reference concepts” is known to have met the CHBDC requirements for crash testing. Jurisdictional usage for each listed “reference concept” is included. The Design Engineer shall confirm the applicability of the of the “reference concept” with respect to crash testing, usage and detailing.

#### **TL-4 “F” Shape with Bicycle Railing**

See the Ministry’s Standard Bridge Parapet (2874-1) for barrier detail.

See the Ministry’s Standard Bridge Parapet Steel Bicycle Railing (2785-3) for railing detail.

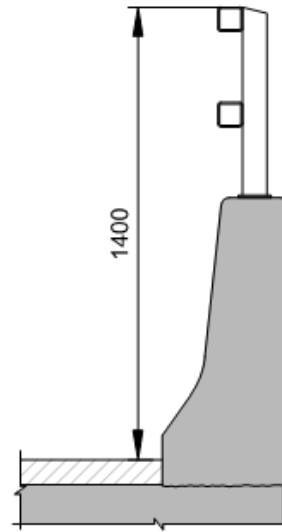

#### **TL-4 “F” Shape with Flush-Post Bicycle Railing**

See the Ministry’s Standard Bridge Parapet (2874-1) for barrier detail.

See the Ministry’s Standard Bridge Parapet Steel Bicycle Railing (2785-4) for railing detail.

**Commentary:** A flush post railing is preferred when a railing is required on top of a barrier that separates traffic from a mixed-used sidewalk.

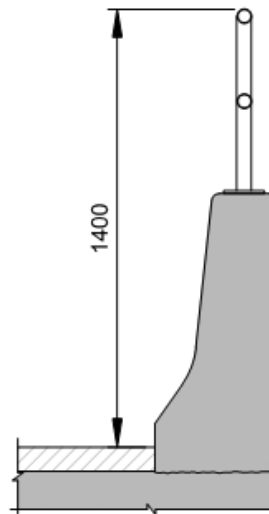

**TL-4 “Tall F” or TL-5 “F” Shape with Pedestrian****Railing**

This is an extended version of the Ministry’s Standard Bridge Parapet (2874-1).

See the Ministry’s Standard Bridge Parapet Steel Railing (2785-2) for railing detail.

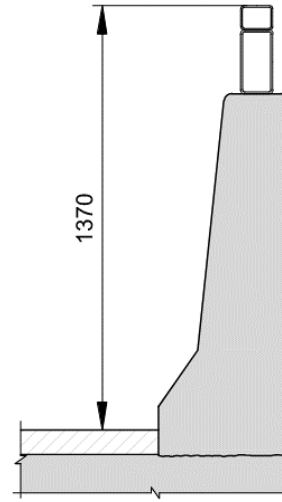
**12.4.6.2 Geometry**

Add the following:

Where combination barriers are installed on sidewalks separated from traffic by raised curbs, the barriers shall be constructed such they are oriented plumb. Otherwise, where combination barriers are installed on the bridge deck, barriers shall be constructed such that they are oriented perpendicular to the deck surface.

**Commentary:** *Combination barriers installed on bridge decks are constructed perpendicular to the deck surface in order that the roadway face of the barrier remains correctly oriented to withstand vehicle impacts.*

# CONFIGURATION #1 - BRIDGE WITH NO SIDEWALK

USAGE: THIS SYSTEM IS SPECIFIED FOR LVR STRUCTURES OR WHERE THE GAP BETWEEN STRUCTURES IS LESS THAN 600 mm. CONSIDERATION SHOULD BE GIVEN TO WORKSAFE BC HEIGHT REQUIREMENTS FOR FALL PROTECTION WHERE APPLICABLE.

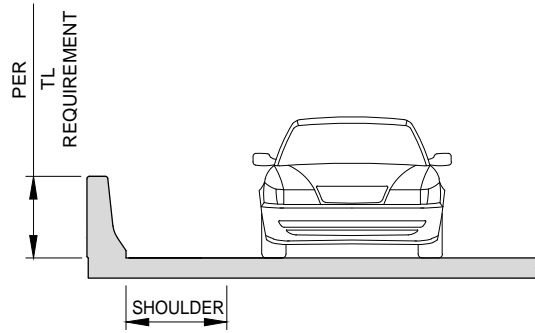

**OPTION A**  
VEHICULAR TRAFFIC ONLY

USAGE: THIS SYSTEM IS FOR NON-LVR STRUCTURES.

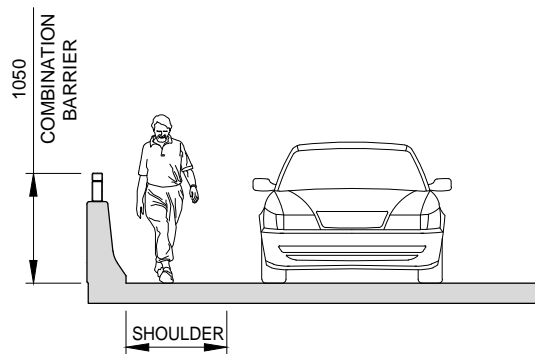

**OPTION B**  
VEHICULAR & PEDESTRIAN TRAFFIC

USAGE: THIS SYSTEM IS SPECIFIED WHERE WARRANTED BY BICYCLE VOLUMES AND/OR WHEN A BICYCLE ROUTE IS IDENTIFIED ACROSS THE BRIDGE.

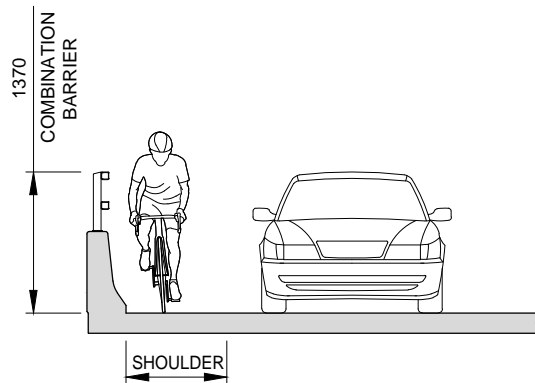

**OPTION C**  
VEHICULAR & CYCLIST TRAFFIC

## NOTES:

1. DIMENSIONS SHOWN ARE CODE MINIMUMS, SYSTEM SPECIFIED HEIGHTS SHALL BE USED.
2. TRAFFIC BARRIER PROTECTION BASED ON THE MINISTRY'S STANDARD BRIDGE PARAPET. OTHER BARRIERS MAY BE ACCEPTABLE.
3. THE USE OF A TRAFFIC BARRIER (OPTION A) IN LIEU OF A COMBINATION BARRIER MAY BE ACCEPTABLE IN REMOTE AREAS, AS RECOMMENDED BY THE DESIGN ENGINEER AND AS CONSENTED TO BY THE MINISTRY, ON THE BASIS OF THE ANTICIPATED VOLUME OF PEDESTRIAN AND/OR BICYCLE TRAFFIC AND GEOMETRIC DETAILS OF THE CROSSING.
4. ALL DIMENSIONS ARE IN MILLIMETRES UNLESS NOTED OTHERWISE.

## CONFIGURATION #2 - BRIDGE WITH RAISED SIDEWALK

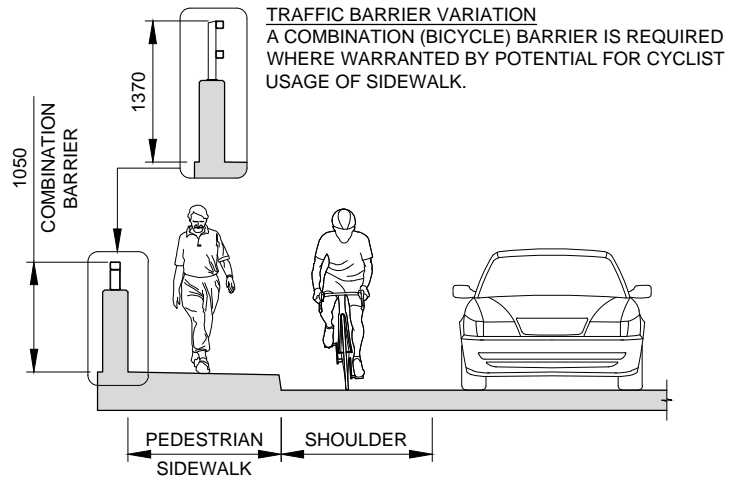

USAGE: THIS SYSTEM IS SPECIFIED WHERE:  
(A) TRAFFIC SPEEDS ARE LESS THAN OR EQUAL TO 60 km/hr  
(B) THE SIDEWALK IS INTENDED FOR PEDESTRIAN USE WITH CYCLISTS USING THE ROADWAY.

### OPTION A VEHICULAR & CYCLIST TRAFFIC ON ROADWAY & PEDESTRIAN TRAFFIC ON SIDEWALK

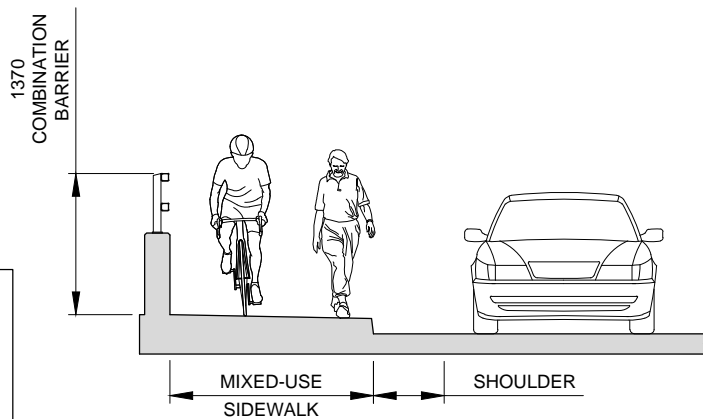

USAGE: THIS SYSTEM IS SPECIFIED WHERE:  
(A) TRAFFIC SPEEDS ARE LESS THAN OR EQUAL TO 60 km/hr  
(B) WHERE BOTH PEDESTRIANS AND CYCLISTS ARE EXPECTED TO USE THE MIXED-USE SIDEWALK.

### OPTION B VEHICULAR TRAFFIC ON ROADWAY & PEDESTRIAN & CYCLIST TRAFFIC ON SIDEWALK

#### NOTES

1. DIMENSIONS SHOWN ARE CODE MINIMUMS, SYSTEM SPECIFIED HEIGHTS SHALL BE USED.
2. MINISTRY STANDARD BRIDGE PARAPET SHALL NOT BE USED FOR THESE CONFIGURATIONS. A BARRIER SYSTEM WHICH HAS BEEN CRASH TESTED IN A RAISED CURB CONFIGURATION SHALL BE USED.
3. ALL DIMENSIONS ARE IN MILLIMETRES UNLESS NOTED OTHERWISE.

# CONFIGURATION #3 - BRIDGE WITH SIDEWALK SEPARATED BY A BARRIER

## TRAFFIC BARRIER VARIATION

A MINIMUM PEDESTRIAN/CYCLIST HEIGHT PROTECTION OF 600mm IS REQUIRED BETWEEN THE SIDEWALK AND ROADWAY ON THE SIDEWALK SIDE. ADDITIONAL PEDESTRIAN/CYCLIST PROTECTION HEIGHT MAY BE CONSIDERED WHERE THE TRAFFIC SHOULDER IS NARROW.

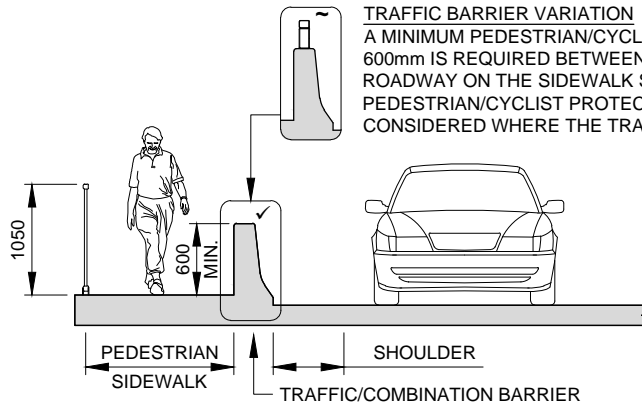

USAGE: THIS SYSTEM IS TYPICALLY SPECIFIED ON HIGH SPEED ROUTES (>60km/hr) WHERE NO CYCLIST TRAFFIC EXPECTED.

### OPTION A

#### VEHICULAR TRAFFIC ON ROADWAY & PEDESTRIAN TRAFFIC ON SIDEWALK

BICYCLE BARRIER VARIATION WHERE THE POTENTIAL FOR CYCLISTS ON THE SIDEWALK IS HIGH, A BICYCLE BARRIER IS RECOMMENDED ALONG THE EDGE OF THE BRIDGE.

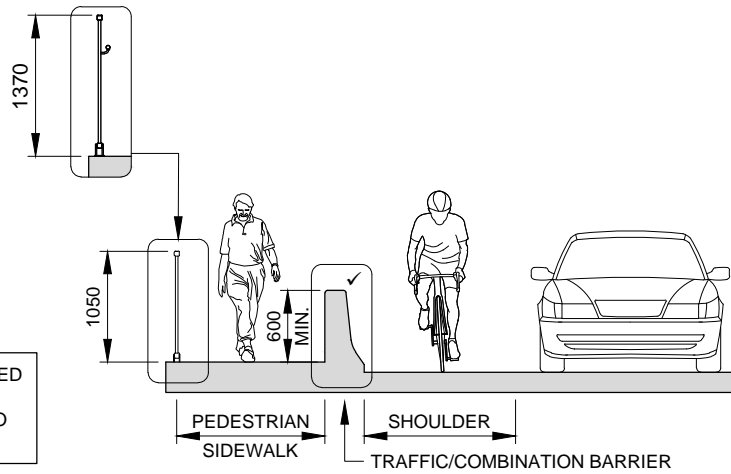

USAGE: THIS SYSTEM IS TYPICALLY SPECIFIED ON HIGH SPEED ROUTES (>60km/hr) WHERE CYCLISTS ARE INTENDED TO USE THE ROADWAY.

### OPTION B

#### VEHICULAR & CYCLIST TRAFFIC ON ROADWAY & PEDESTRIAN TRAFFIC ON SIDEWALK

## TRAFFIC BARRIER VARIATIONS

A MINIMUM PEDESTRIAN/CYCLIST HEIGHT PROTECTION OF 600mm IS REQUIRED BETWEEN THE SIDEWALK AND ROADWAY ON THE SIDEWALK SIDE. ADDITIONAL PEDESTRIAN/CYCLIST PROTECTION HEIGHT MAY BE CONSIDERED WHERE THE TRAFFIC SHOULDER IS NARROW.

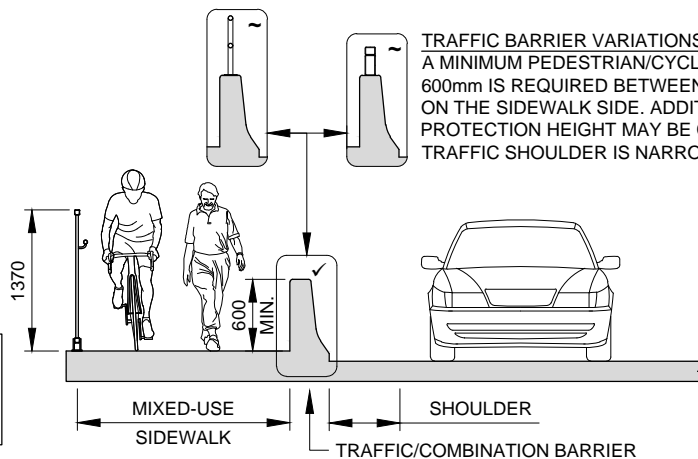

USAGE: THIS SYSTEM IS TYPICALLY SPECIFIED ON HIGH SPEED ROUTES (>60km/hr) WHERE SIDEWALK IS DEDICATED TO MIXED USE.

### OPTION C

#### VEHICULAR TRAFFIC ON ROADWAY & PEDESTRIAN & CYCLIST TRAFFIC ON SIDEWALK

#### NOTES:

1. DIMENSIONS SHOWN ARE CODE MINIMUMS, SYSTEM SPECIFIED HEIGHTS SHALL BE USED.
2. TRAFFIC BARRIER BASED ON THE MINISTRY'S STANDARD BRIDGE PARAPET. OTHER BARRIERS MAY BE ACCEPTABLE.
3. ALL DIMENSIONS ARE IN MILLIMETRES UNLESS NOTED OTHERWISE.

#### LEGEND

- ✓ ACCEPTABLE CONFIGURATION
- ~ MAY BE AN ACCEPTABLE CONFIGURATION