

June 28, 2023  
Project No.: 0272102

Heidi Evensen, Senior Geotechnical Engineer  
B.C Ministry of Transportation and Infrastructure  
850C – 16 Street NE  
Salmon Arm, BC  
Mailing Address: Box 100 Station Main, Salmon Arm, BC V1E 4S4  
Via email: Heidi.Evensen@gov.bc.ca

**Re: Crazy Creek Bridge –Geotechnical Assessment of Scour and Erosion Mitigation Design**

## **1.0 INTRODUCTION**

BGC Engineering Inc. (BGC) was requested by the BC Ministry of Transportation and Infrastructure (MoTI) to carry out a high-level geotechnical assessment for the proposed scour and erosion mitigation design for the Crazy Creek Bridge (the Bridge), located near Craigellachie, BC. The Bridge structure (Structure ID 01524) is located on Highway 1 at Landmark Kilometer Inventory (LKI) Segment 1812 at 32.76 km.

The Bridge is a single span with a length of 25.6 m built in 1958 with historical as-built record drawings showing the concrete bridge abutments constructed as spread footings at an embedment depth of about 4.8 m below the bridge soffit elevation. Available record drawings are provided in Appendix A.

BGC's hydrotechnical group completed a scour/erosion analysis evaluation (BGC, May 17, 2021) of the crossing which included a scour mitigation design. The design drawings were updated and provided to MoTI as Issued For Permitting on February 22, 2023; those drawings are provided in Appendix B. The proposed scour mitigation design includes the addition of riprap around the abutment and wingwall foundations which extends a short distance upstream and downstream.

### **1.1. Scope of Work**

The general scope of services for this work was provided in BGC's proposal entitled "*Crazy Creek Bridge - Work Plan and Cost Estimate for Preliminary Geotechnical Assessment*" and dated December 21, 2022. The geotechnical work scope outlined as part of the larger scope included:

1. Desktop review of the available geotechnical information.
2. Geotechnical slope stability assessment of the bridge abutments before and after the installation of the proposed erosion mitigation design to assess before, during and after construction conditions.

3. Geotechnical input to the proposed BGC's scour mitigation design.
4. Site visit to validate assumptions used in this assessment (site visit completed April 26, 2023).

All work was completed under the existing As & When for Hydrotechnical Engineering Design Services contract (Contract No. 831CS1095) between BGC and MoTI,

## **2.0 GEOTECHNICAL DESKTOP REVIEW**

BGC reviewed the as-built records by Crippen Write Engineering (MoTI, 1958) which included the three drawings titled:

1. Crazy Creek Bridge General Arrangement.
2. Crazy Creek Bridge Abutments Concrete Outline and Reinforcement.
3. Crazy Creek Bridge Site Plan and Profile.

The three drawings are included in Appendix A. The scans of the drawings are not clear for some parts of the drawings and some inferences were made based on what can be interpreted from other notes.

### Available Subsurface Data

The Crazy Creek Bridge General Arrangement drawing (Appendix A) shows two lithology stick logs Drill Hole No.1 and Drill Hole No. 2 (DH.1 and DH.2). DH.1 is shown directly under the west abutment centerline and DH.2 is shown about 20 m east of the east abutment and along the east bound approach embankment shoulder. The stick log for DH.1 describes the material as rocks (inferred to be gravel and cobbles) and silty sand within the upper 8 m, underlain by about 20 m of sand and fine gravel. The stick log for DH.2 describes the material as gravel, sand and boulders with trace silt for the entire 21 m of the log.

The drawings also show that the west abutment was excavated down into the existing ground which creates the current thru-cut at the abutment. The slopes of the thru-cut are recorded as 1 on 1.5 (inferred as 1.5:1 horizontal to vertical) and the west channel slopes (slopes into Crazy Creek) as 1 on 2 (inferred as 2:1 horizontal to vertical). The east abutment and approach-embankment appears to have been constructed within the old Crazy Creek Channel, that was diverted west as part of the Bridge construction. The approach embankment on the downstream side (slopes running perpendicular to the road alignment) show fill slopes with angles of 1 on 1.5 (inferred as 1.5:1 horizontal to vertical). The east channel slopes (slopes into Crazy Creek) are shown as 1 on 2 (inferred as 2:1 horizontal to vertical).

Records do not indicate the type of material used in the construction of the fill embankments, but it is interpreted that the fill material would have been the granular material excavated to build the abutments.

A search of the BC Groundwater Wells and Aquifer online database indicates several well records within a 500 m radius, with six of the wells providing lithology logs from the drilling. Well Tags 71900, 71898, 44453, 134 and 133 have been logged to have similar conditions with gravel and

boulders depths ranging between 6.1 m to 8.5 m from surface, underlain by gravels to depths ranging between 23.8 to 34 m followed by silt below 23.8 m in some of the logs.

BGC also did a search for published surficial geology maps surrounding the site. The surficial geology in the vicinity of the Bridge is described as colluvial and mass-wasting deposit (undifferentiated deposits) (BC Geological Survey, 2019). Based on visual observations by BGC's hydrotechnical group (BGC, May 17, 2021) and review of available photographs from within the project limits, the surficial soils within the current channel bed appears comprise mainly of a cobbles and boulders some gravel and trace amounts of sand.

#### Review of Ministry Condition Inspection Report

BGC has reviewed the most current Ministry Condition Inspection Report dated September 9, 2022. Select items relevant to the geotechnical aspects include (as worded from the inspection report):

- Section 5 Foundation Movement – 2022 No foundation movement noted.
- Section 6 Abutments – 2022 East Abutment, several medium vertical cracks in breast wall. 2022 West Abutment, scour holes and light erosion of breast wall at water level. Vertical cracks in breast wall.
- Section 9 Footing/Piling – 2022 East Abutment – footing not visible. 2022 West Abutment – footing visible, exposed reinforcement above footing on the full width.
- Section 40 Roadway Approaches – 2022 West Approach, minor settlement.

#### Additional Review Comments

A review of the historical Crazy Creek General Arrangement drawing (Appendix A), appears to show backfill in front of the concrete abutment walls (along the river channel) placed to within 0.3 m of the drain holes on the walls. Recent photographs from within the channel show the west abutment foundation exposed which would suggest that about 2.3 m material has been eroded from the channel since it was originally constructed. MoTI also provided a photograph from August 2008 which appears to show similar conditions to the current conditions with the west abutment channel flow at a similar elevation below the drain holes.

### **3.0 SITE RECONNAISSANCE**

A field reconnaissance was carried out by BGC (Ian Polos, P.Eng.) on April 26, 2023 at the Bridge site with purposes of making observations of the current site conditions and to validate assumptions used in this assessment. MoTI (Heidi Evensen, P.Eng.) accompanied BGC during the site reconnaissance. BGC's observations and commentary are summarized below with select photographs in Appendix D.

The material within the channel bed in the vicinity of the Bridge can generally be described as cobbles and boulders with some fine to coarse gravel and coarse sand. Particle shape was observed to be generally rounded to sub-angular. Large boulders (1 to 2 m in diameter) were observed throughout the channel with a higher concentration of boulders upstream of the Bridge. Three large boulders could be observed directly adjacent to the west foundation wall.

### **East Abutment**

- East abutment area is shown in Photographs 1 to 4 and 10.
- BGC observed that there is no riprap armour against the foundation wall and at the downstream wingwall. Some cobbles and boulders were present at the upstream wingwall.
- Gabion baskets (total basket area about 1.9 m long by 1.8 m high) were observed extending downstream of the east abutment wingwall, shown in Photograph 4. BGC infers that the baskets were installed as a result of a loss of creek channel bed material and to maintain road embankment material. The baskets appear to have reached their service life with the basket infill bulging and some damaged/disconnects in the basket wires, shown in Photograph 11. The baskets are retaining soil behind the wingwall with no evidence of tension cracks behind the wall.
- A hairline crack was observed between the last two downstream drain holes on the abutment wall. The crack was vertical and extended from the top of the foundation wall to within 0.5 m of the gravel channel bed. A crack aperture of 1 mm or less was measured.
- The upstream wingwall geometry is nearly perpendicular to Highway 1 alignment which is slightly different than the Issued For Permit (IFP) drawings in Appendix B.

### **West Abutment**

- West abutment area is shown in Photographs 5 to 9.
- BGC observed that there is no riprap armour against the foundation wall and at the downstream wingwall. Some cobbles and boulders were present at the upstream wingwall.
- Due to elevated creek flows, BGC was not able to walk under the bridge and observe the foundation wall and could only be observed from a distance.
- The downstream wingwall geometry is nearly perpendicular to Highway 1 alignment which is slightly different than the IFP drawings in Appendix B. The embankments slope immediately downstream of wingwall are very steep.

## **4.0 ENGINEERING ASSESSMENT**

### **4.1. Seismic Hazard**

For the purposes of assessing stability of the earth embankments during a seismic event, the Crazy Creek Project will follow the Canadian Highway Bridge Design Code, CHBDC (CSA, 2019, Section 6-19) where possible, which refers to the seismic hazard provisions of the current National Building Code of Canada (NBCC) (CCBFC, 2020). The classification for seismic site response considers the average properties of the top 30 m of the soil profile.

In the absence of shear wave velocity data and Standard Penetration Test (SPT) blow counts, the seismic site classification was estimated based lithology records from nearby boreholes drilled to near 30 m, as discussed in Section 2.0. Using this information and the materials described, the site appears to most consistent with a Class C (very dense soil) for the purposes of this project.



Below are the PGA (Peak Ground Acceleration) values from both the 2015 and 2020 Building Codes that will be considered for assessment of the embankment stability. The values given below are for a ground motion with a return period of 1 in 975 years.

- PGA from 2015 NBCC (Site Class C) – 0.036 g
- PGA from 2020 NBCC (Site Class C) – 0.045 g.

BGC has assumed that the foundation soils have low potential for liquefaction based on the information reviewed; hence, no effort for liquefaction assessment has been included herein.

#### **4.2. Embankment Stability Assessment**

Slope stability analyses were completed to calculate the factor of safety (FoS) of the existing slopes, as well as during and after construction of the proposed riprap protection. The analysis was carried out using the two-dimensional limit equilibrium software Slope/W distributed by Geo-Slope International Ltd. (2021). All analyses were completed using the Morgenstern-Price method.

For analysis purposes, the degree of understanding and consequence is considered “typical” based on the information reviewed and considering that the bridge is a short span bridge crossing a relatively small creek of Highway 1.

Groundwater conditions were estimated based on the fluctuations of Crazy Creek with estimated levels in the embankment soils at elevated levels, as cautious approach for assessing the stability scenarios.

Two cross sections, one at the west bridge abutment footing and the second at the downstream embankment, were analyzed at the locations shown in Appendix C, Figure C-1. The cross section at the west abutment has been considered representative of the anticipate conditions that will be encountered at both the east and west abutments and wingwalls, therefor no stability scenarios of the east abutment have been carried out as results would be similar to those of the west abutment. The typical sections in the IFP Drawings (Appendix B) show riprap depth extending to a depth to the scour elevation or a depth below scour elevation but at both abutments the specified burial depth of riprap is the same, 1.5 m below the top of footing. The cross section and bridge footing geometry was taken from the preliminary permitting design drawings (Appendix B) prepared by BGC and developed from the historical record drawings (MoTI,1958).

The material parameters used for the slope stability analyses are summarized in Table 4-1 and were estimated based on the information discussed in Section 2.0 and BGC’s experience with similar materials.

**Table 4-1. Soil parameters for slope stability analyses.**

Soil Layer	Unit Weight (kN/m <sup>3</sup> )	Effective Cohesion (kPa)	Friction Angle (degrees)
Existing Ground (Cobbles and Boulders, some gravel, some sand)	22	0	38
Bridge End Fill (Sand and Gravel)	21	0	36
Riprap (Class 500 kg, angular cobbles and boulders)	23.5	0	45
Reinforced Concrete	24	High Strength (impenetrable)	

The following cases were analyzed for the section at West Abutment and West Embankment as the anticipated critical scenarios:

1. Case 1: Existing conditions (baseline conditions) with a river level near the top of footing or at an elevation of the existing channel bed with an elevated piezometric surface behind the footing wall.
2. Case 2: Same as Case 1 but with a seismic load applied.
3. Case 3: Simulates the temporary excavation required to install the riprap protection with an elevated piezometric surface behind the footing wall but at a slightly lower elevation than Case 1.
4. Case 4: Following riprap placement (post remediation conditions) with a river level near the top of the footing or at an elevation of the existing channel bed with an elevated piezometric surface behind the footing wall.
5. Case 5: Same as Case 4 but with a seismic load applied.
6. Case 6: Scour conditions with loss of channel bed material down to the design scour depth and assuming no loss in riprap armor thickness against the footing and embankment.

Other assumptions for the slope stability analyses are as follows:

1. For the seismic case considered assume Crazy Creek as “lifeline geotechnical system” which indicates that at least 50% of the travelling lanes should be available following ground motions with a return period of at least 975-years, as outlined in Section 6.14.2.3 in Bridge Standards and Procedures Manual Volume 1 MoTI’s Supplement to CSA S6:19 Canadian Highway Bridge Design Code (CHBDC Supplement) (MoTI, July 2022). The seismic cases (Case 2 and Case 5) analysis considers a horizontal seismic load of 100% of the PGA based on 975-year return period for PGA from 2020 NBCC which corresponds to 0.045 g.
2. A live load surcharge to simulate heavy vehicle traffic within the travelling lane was considered and has been represented by a 20 kPa strip load at the abutment approach.
3. Based on review on available subsurface data and photographs of site, it is assumed the abutment and embankment soils are relatively free draining and a rapid draw down scenario is unlikely to occur.
4. Based on the available subsurface information, the soil parameters used in the analyses are considered lower bound values, and the groundwater conditions are considered upper bound values. Thus, no further sensitivity analyses are necessary at this time.

MoTI Technical Circular Geotechnical Design Criteria T-04/17 provides direction for soil slope and embankment design. Based on Table 6.2b of MoTI’s Supplement to CHBDC S6-19 (MoTI, July 2022), the required minimum factor of safety (FoS) for global stability of embankments with a typical degree of understanding and typical consequence factor is 1.54 for permanent conditions (Case 1, Case 4 and Case 6) and 1.33 for temporary conditions (Case 2) and 1.10 for seismic conditions using a pseudo static analysis (Case 2 and Case 5). The required factor of safety of 1.10 for pseudo static condition was provided in Technical Circular T-04/17 dated March 22, 2017.

The results of the stability analyses are presented in Table 4-2 below.

**Table 4-2. Results of stability analyses for the critical sections.**

Case Description	Factor of Safety	Target Factor of Safety	Appendix C Reference (Figure No.)
<b>West Abutment Section (through bridge abutment foundation)</b>			
Case 1: Existing conditions	1.60	<b>1.54</b>	<b>C-2</b>
Case 2: Existing conditions with seismic load (seismic)	1.50	<b>1.10</b>	<b>C-3</b>
Case 3: Temporary excavation prior to riprap placement (temporary)	1.37	<b>1.33</b>	<b>C-4</b>
Case 4: Post remediation conditions (permanent)	1.81	<b>1.54</b>	<b>C-5</b>
Case 5: Post remediation conditions with seismic load (seismic)	1.65	<b>1.10</b>	<b>C-6</b>
Case 6: Post remediation condition with scour (permanent)	1.60	<b>1.54</b>	<b>C-7</b>
<b>West Embankment Section</b>			
Case 1: Existing conditions	1.57	<b>1.54</b>	<b>C-8</b>
Case 2: Existing conditions with seismic load (seismic)	1.48	<b>1.10</b>	<b>C-9</b>
Case 3: Temporary excavation prior to riprap placement (temporary)	1.36	<b>1.33</b>	<b>C-10</b>
Case 4: Post remediation conditions (permanent)	1.77	<b>1.54</b>	<b>C-11</b>
Case 5: Post remediation conditions with seismic load (seismic)	1.60	<b>1.10</b>	<b>C-12</b>
Case 6: Post remediation condition with scour (permanent)	1.65	<b>1.54</b>	<b>C-13</b>

Note:

- Case 6, Figure C-7 and Figure C-13 represent a scenario where the riprap embedment extending below the design scour as shown on the typical sections of the IFP drawings (Appendix B). Some of the typical sections show the riprap embedment extending to the design scour. Based on the results shown in Figure C-7 and C-13 for Case 6, BGC anticipates little to no significant change to the global stability results for riprap extending slightly below or at the design scour elevation.

The results of the global stability analysis indicate there will be an overall improvement from the existing conditions with the proposed scour protection. The temporary excavation needed to

implement the scour protection adjacent to the footing and at the toe of the embankment meet the temporary FoS targets. The anticipated scenarios assessed as described in Table 4-2 were able to achieve the required target factors of safety.

#### **4.3. Review of the Ministry Condition Inspection Reports**

The Ministry's most recent visual inspection from September 9, 2022 suggests that only minor defects and minor approach settlement has been observed as a result of loss of channel bed material on top of the shallow footings. This loss of channel material appears to date back to August 2008 (at least), based on a photograph provided by the Ministry. This prolonged condition suggests the footings have generally performed well over this period.

### **5.0 GEOTECHNICAL RECOMMENDATIONS**

#### **5.1. Geotechnical Input to the Hydrotechnical Design Drawings**

BGC's has provided geotechnical input to the hydrotechnical scour mitigation and erosion protection design drawings dated February 22, 2023. The geotechnical input included:

1. The permanent slopes of 1.5:1 (H:V) for the riprap armoring are suitable as proposed. Excavations for placement of the riprap at the abutment and wingwall footings shall start at an elevation no lower than the top of the footing.
2. Riprap used for scour protection should be fully resting on or below the design scour elevation.
3. Given the potential for sandy pockets and to account for water flow fluctuation, it is recommended that a suitable non-woven geotextile shall be used between the foundation and embankment soils and the riprap to provide material separation. Geotextile shall be placed over top of the footing or keyed into at the top of the riprap on the embankment slopes.
4. The riprap proposed on the east abutment should also wrap around the abutment footing and its wingwalls at both the upstream and downstream extents.

Following the April 26, 2023 site visit, BGC recommends the following items are incorporated as part of the mitigation work.

1. Where the wire facing on the gabion basket is damaged/disconnected (Photograph 11), it is recommended that additional wiring (of similar gauge) be stitched to close gaps in the basket.
2. At the downstream east abutment wingwall, the existing gabion wall can remain provided the riprap extends up to support the base of the gabion and prevent lateral movement. From a geotechnical perspective, it is recommended that there is no excavation of the soil down slope the gabion basket and only minimal stripping, 150 mm or less, occurs prior to the placement of riprap in this area. The placement of riprap should occur immediately following stripping activities. Visual monitoring and inspection shall occur (by a qualified person) during stripping, once the foundation soils are exposed and ongoing until riprap backfill is in place.

## **5.2. Additional Geotechnical Considerations**

BGC recommends the following considerations during construction, as they relate to the geotechnical aspects:

1. During excavation near the Bridge foundations and wingwalls, visual and topographic survey monitoring of the structure should be carried out and should include monitoring for signs of foundation movement, new cracking and expanding existing cracking. Soils within the excavation near the foundations should be documented and visually classified for verification with assumptions made in this assessment.
2. Excavation work should occur during low flow creek conditions when porewater pressures in the embankment are estimated to be at their lowest levels.

## 6.0 CLOSURE

BGC Engineering Inc. (BGC) prepared this document for the account of BC Ministry of Transportation and Infrastructure. The material in it reflects the judgment of BGC staff in light of the information available to BGC at the time of document preparation. Any use which a third party makes of this document or any reliance on decisions to be based on it is the responsibility of such third parties. BGC accepts no responsibility for damages, if any, suffered by any third party as a result of decisions made or actions based on this document.

Yours sincerely,

**BGC ENGINEERING INC.**  
per:



A circular professional engineer seal for the Province of British Columbia. The seal contains the text: "PROFESSIONAL ENGINEER", "PROVINCE OF BRITISH COLUMBIA", "I. K. POLOS", and "# 49172". To the right of the seal, the date "28 JUN 2023" is handwritten. Below the seal is a handwritten signature in black ink.

Ian Polos, P.Eng.  
Geotechnical Engineer

Reviewed by:

Luis Martinez, M.Eng., P.Eng.  
Senior Geotechnical Engineer

EGBC Permit to Practice, BGC Engineering Inc. 1000944

HW/LM/md/mm

Attachment(s): Appendix A – Historical As-Built Drawings  
Appendix B – Preliminary Mitigation Design (Issued for Permitting February 22, 2023)  
Appendix C – Stability Results  
Appendix D – Select Site Photographs

## REFERENCES

- BGC Engineering Inc. (2022, December 21). Crazy Creek Bridge - *Work Plan and Cost Estimate for Preliminary Geotechnical Assessment*. Prepared for the Ministry of Transportation and Infrastructure.
- BGC Engineering Inc. (2021, May 17). BC Ministry of Transportation and Infrastructure Scour/Erosion Evaluation report. Prepared for the Ministry of Transportation and Infrastructure.
- British Columbia Ministry of Transportation and Infrastructure (MoTI). (2022, July). Bridge Standards and Procedures Manual Volume Supplement to CHBDC S6:19. Adopted July 2022.
- British Columbia Ministry of Transportation and Infrastructure (MoTI). (1958). Revelstoke District Trans-Canada Highway Mile 492.45: Crazy Creek Bridge Record Drawings”. Crippen Wright Engineering Ltd. N.D.
- British Columbia (BC) Geological Survey. (2019). Surficial geology Map Layer. Map Place 2. From: <https://www2.gov.bc.ca/gov/content/industry/mineral-exploration-mining/british-columbiageological-survey/mapplace>
- Canadian Commission on Building and Fire Codes (CCBFC). (2020). National Building Code of Canada.
- Canadian Standards Association (CSA). 2019 November. Canadian Highway Bridge Design Code No. CSA-S6-19.
- GEO-SLOPE International. (2021). Slope/w Slope Stability Software, Version 11.0. Calgary, AB, Canada.

## **APPENDIX A HISTORICAL AS-BUILT DRAWINGS**



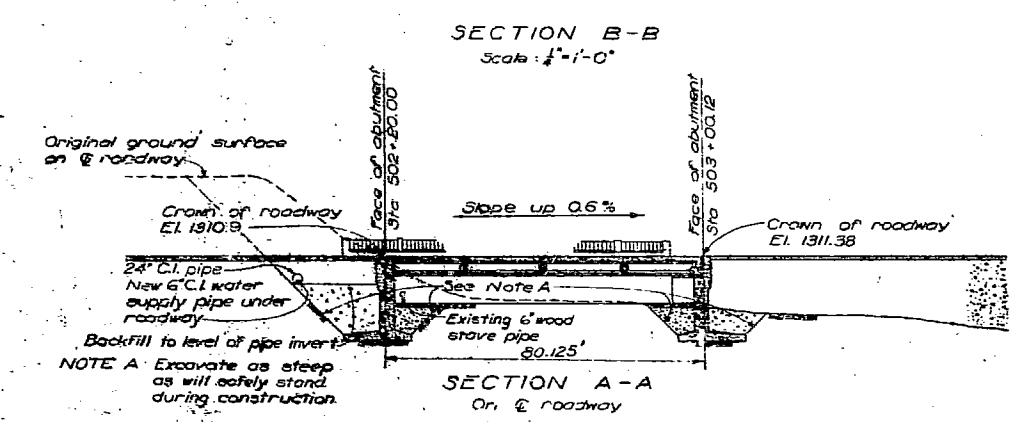
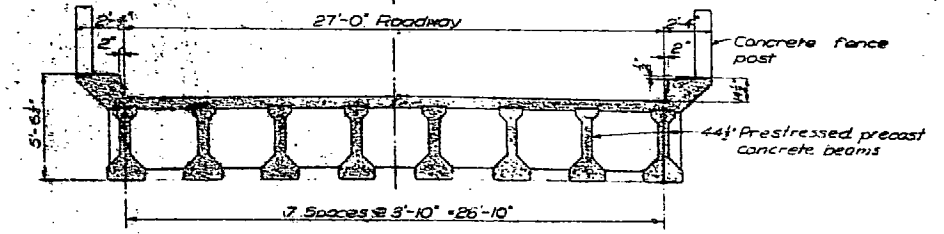
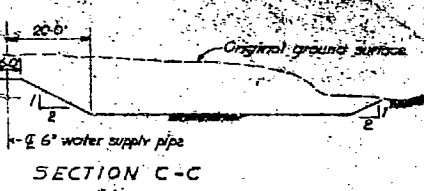

- REFERENCE DRAWINGS**
- 1524-B Abutment Concrete Outline Reinforcement
  - 1524-C Roadway Concrete Slabs & Diaphragms
  - 1524-D Concrete Outline & Reinforcement
  - 1524-E Miscellaneous Materials
  - 2576 Standard Roadway Fence (height 2'-0")
- NOTES**
- Construction of bridge approaches not included in this contract.

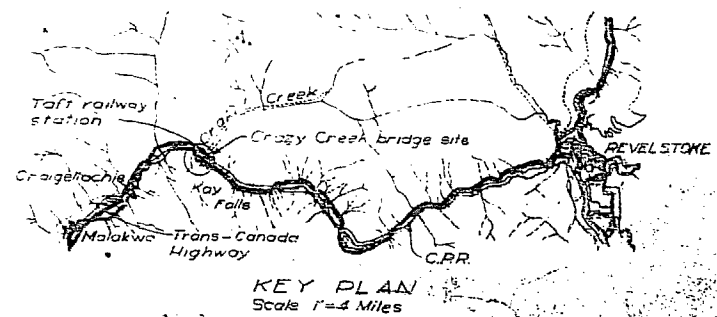
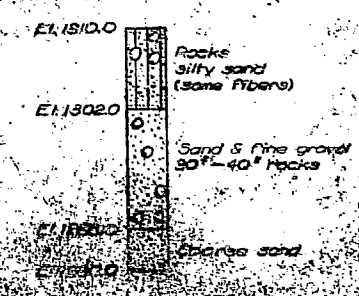
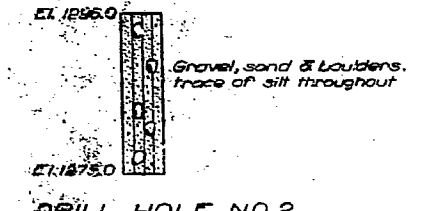

Scale 1"=20'

AS-BUILT

BRITISH COLUMBIA DEPARTMENT OF HIGHWAYS

REVELSTOKE DISTRICT

TRANS-CANADA HIGHWAY M.E. 4324D

**OFFICE COPY**

GENERAL ARRANGEMENT

CRIPPEN WRIGHT ENGINEERING LTD.

100450

NO.	DATE	BY	CHECKED	APPROVED
1	1957	W.S.	W.S.	W.S.
2	1957	W.S.	W.S.	W.S.
3	1957	W.S.	W.S.	W.S.
4	1957	W.S.	W.S.	W.S.
5	1957	W.S.	W.S.	W.S.





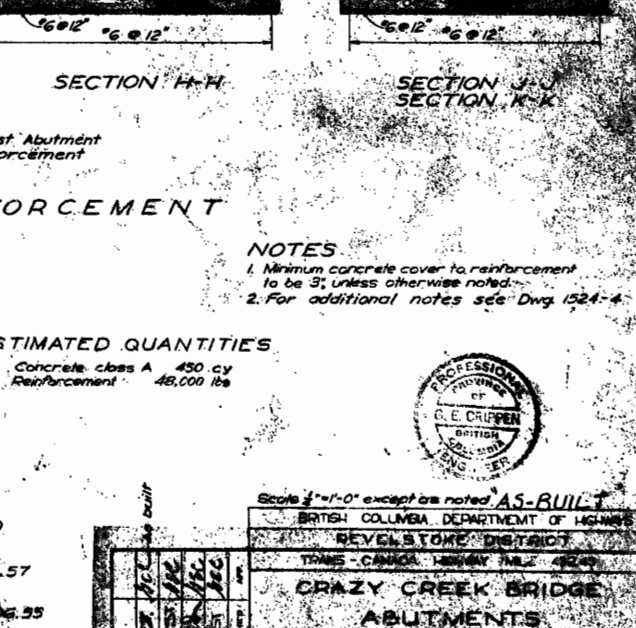
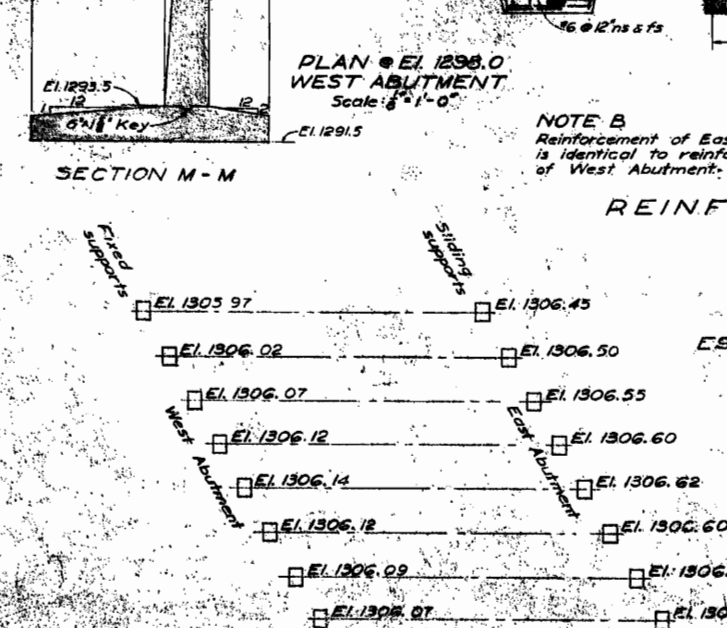
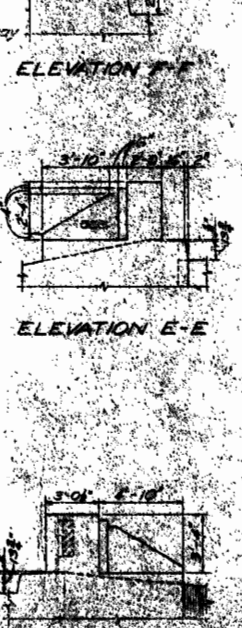
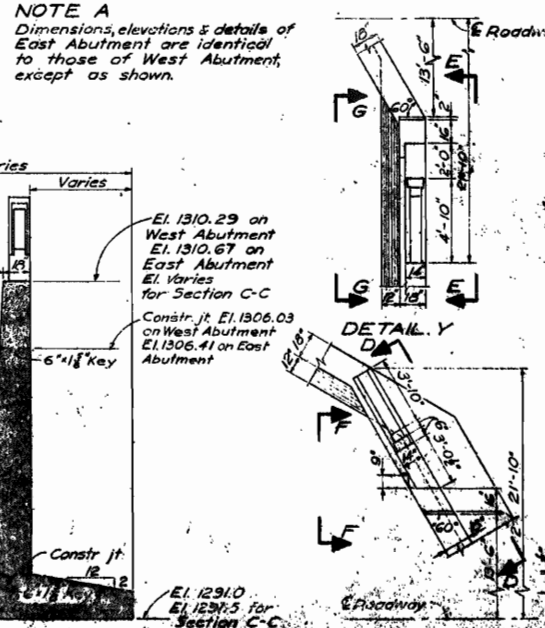
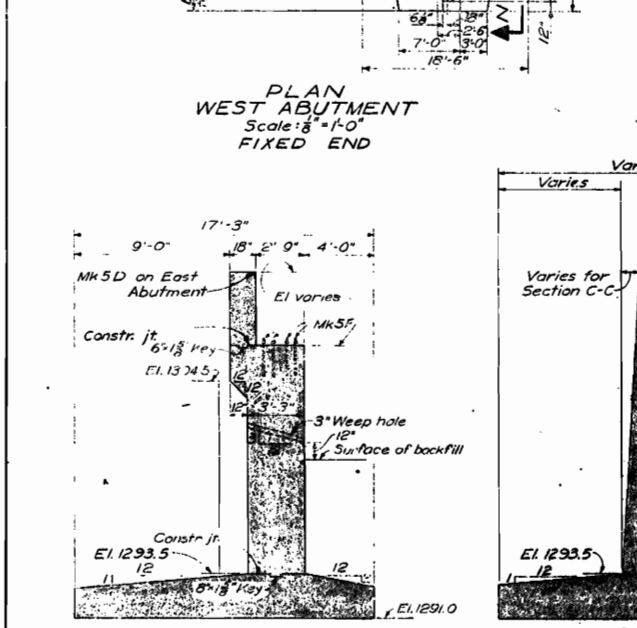
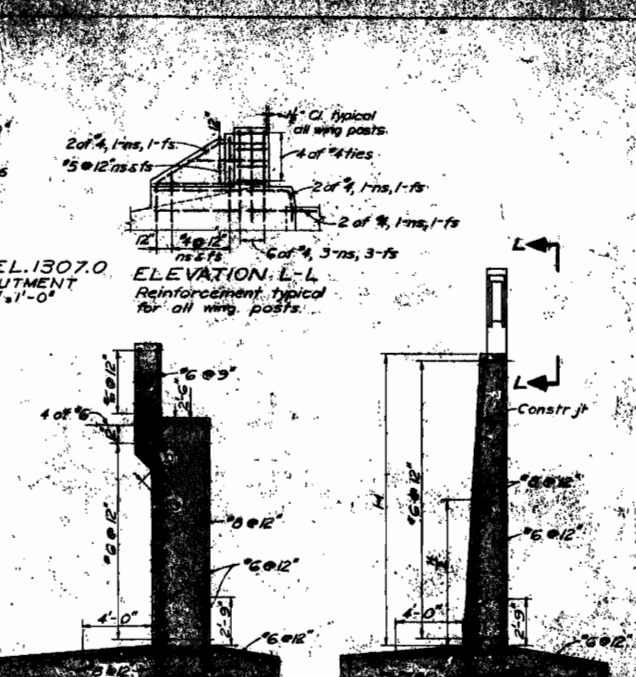
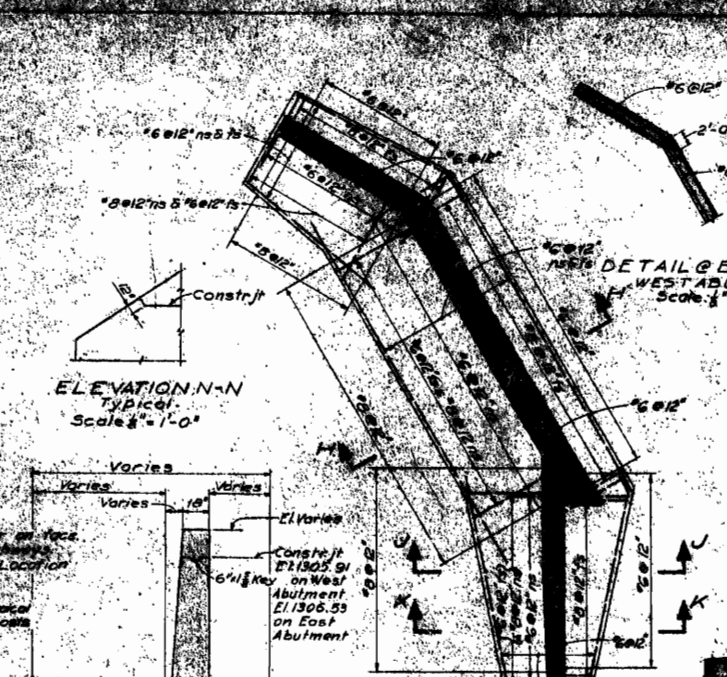
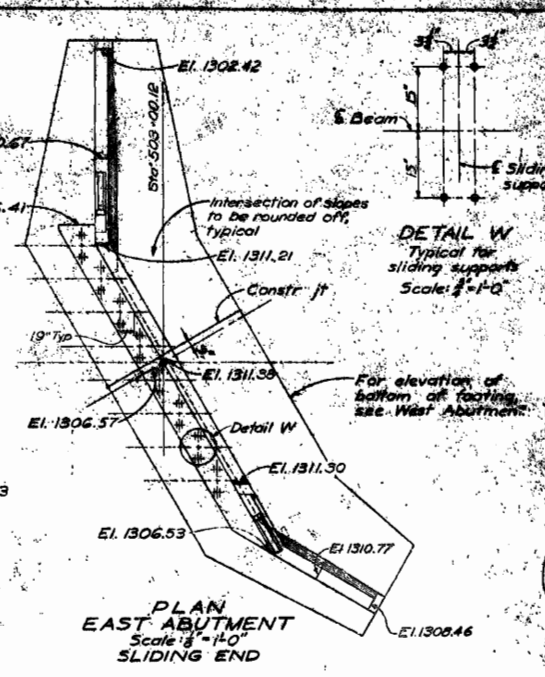
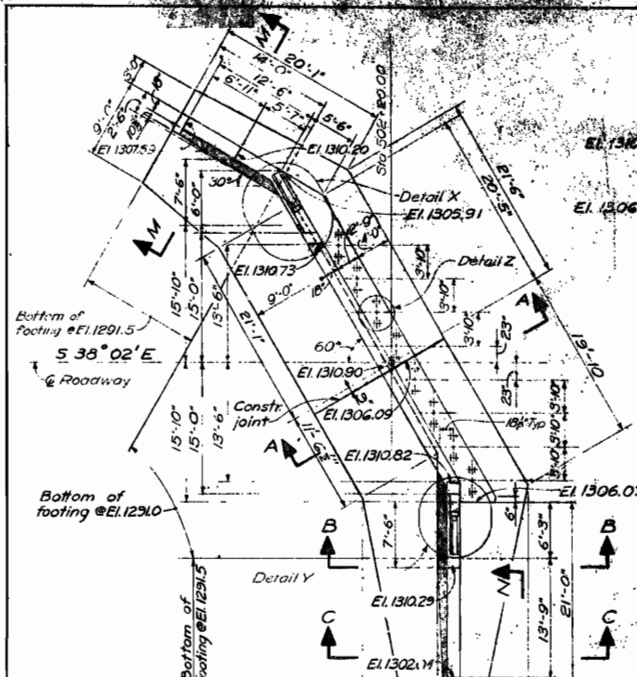

**NOTE A**  
Dimensions, elevations & details of East Abutment are identical to those of West Abutment, except as shown.

**NOTE B**  
Reinforcement of East Abutment is identical to reinforcement of West Abutment.

**NOTES**  
1. Minimum concrete cover to reinforcement to be 3", unless otherwise noted.  
2. For additional notes see Dwg. 1524-4

**ESTIMATED QUANTITIES**  
Concrete class A 450 cy  
Reinforcement 48,000 lbs



**CONCRETE OUTLINE**

**PLAN OF BEDPLATES**  
Showing bottom elevations of bedplates (This is scale)

Scale 3/8"=1'-0" except as noted AS-BUILT

BRITISH COLUMBIA DEPARTMENT OF HIGHWAYS  
REVELSTOCK DISTRICT  
TRINIS - CANADA, HIGHWAY 111E, 112E

**CRAZY CREEK BRIDGE ABUTMENTS**

CONCRETE OUTLINE & REINFORCEMENT 1955

WILSON WRIGHT ENGINEERING LTD.

NO.	DESCRIPTION	QTY.	UNIT
1	CONCRETE	450	CY
2	REINFORCEMENT	48,000	LB

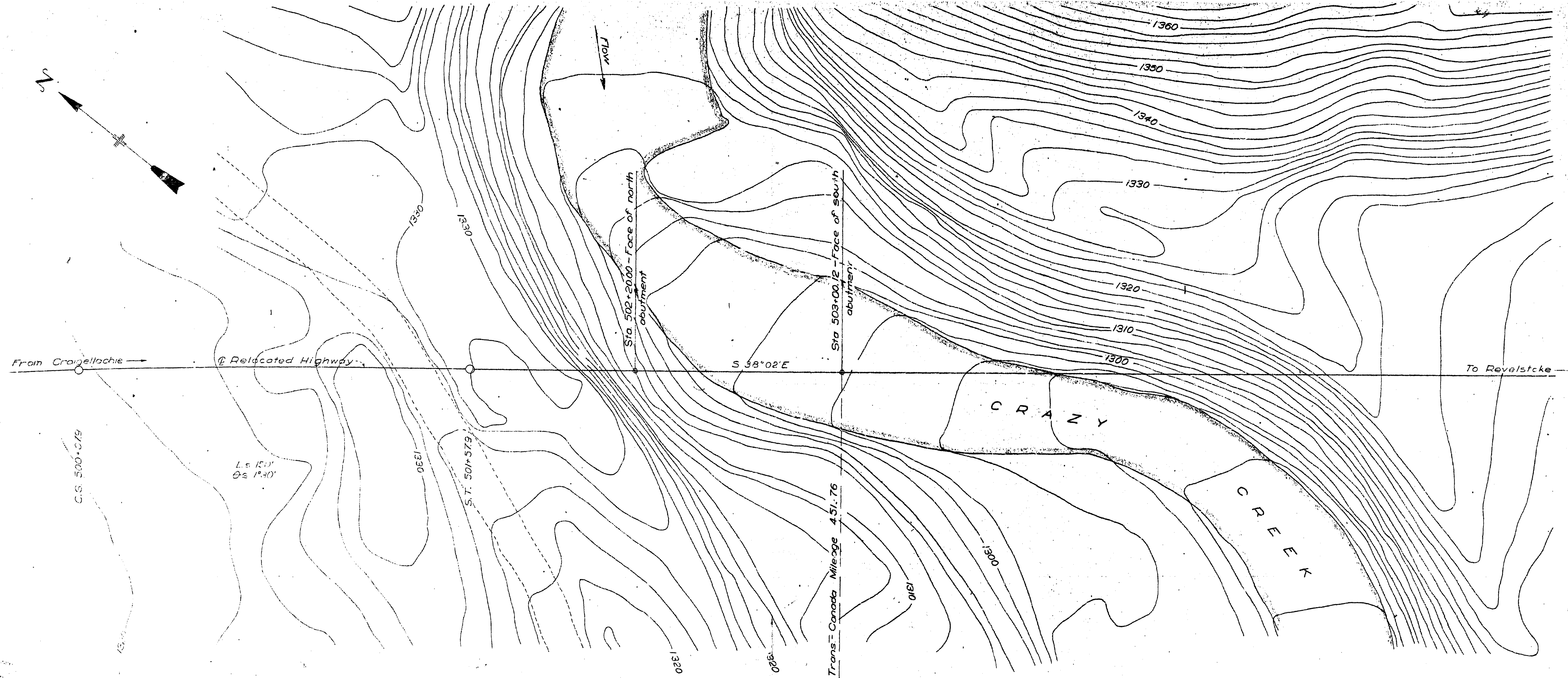

SITE PLAN  
Scale 1" = 20'

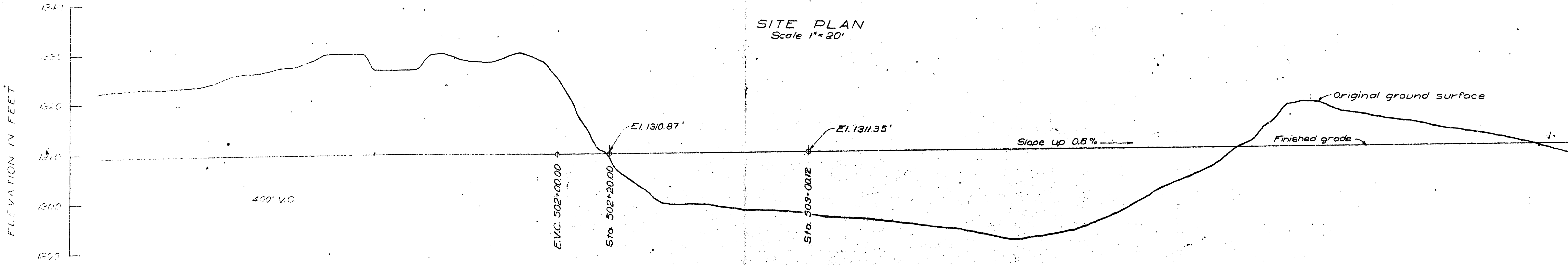

PROFILE  
Scale 1" = 20' Horizontal  
1" = 10' Vertical

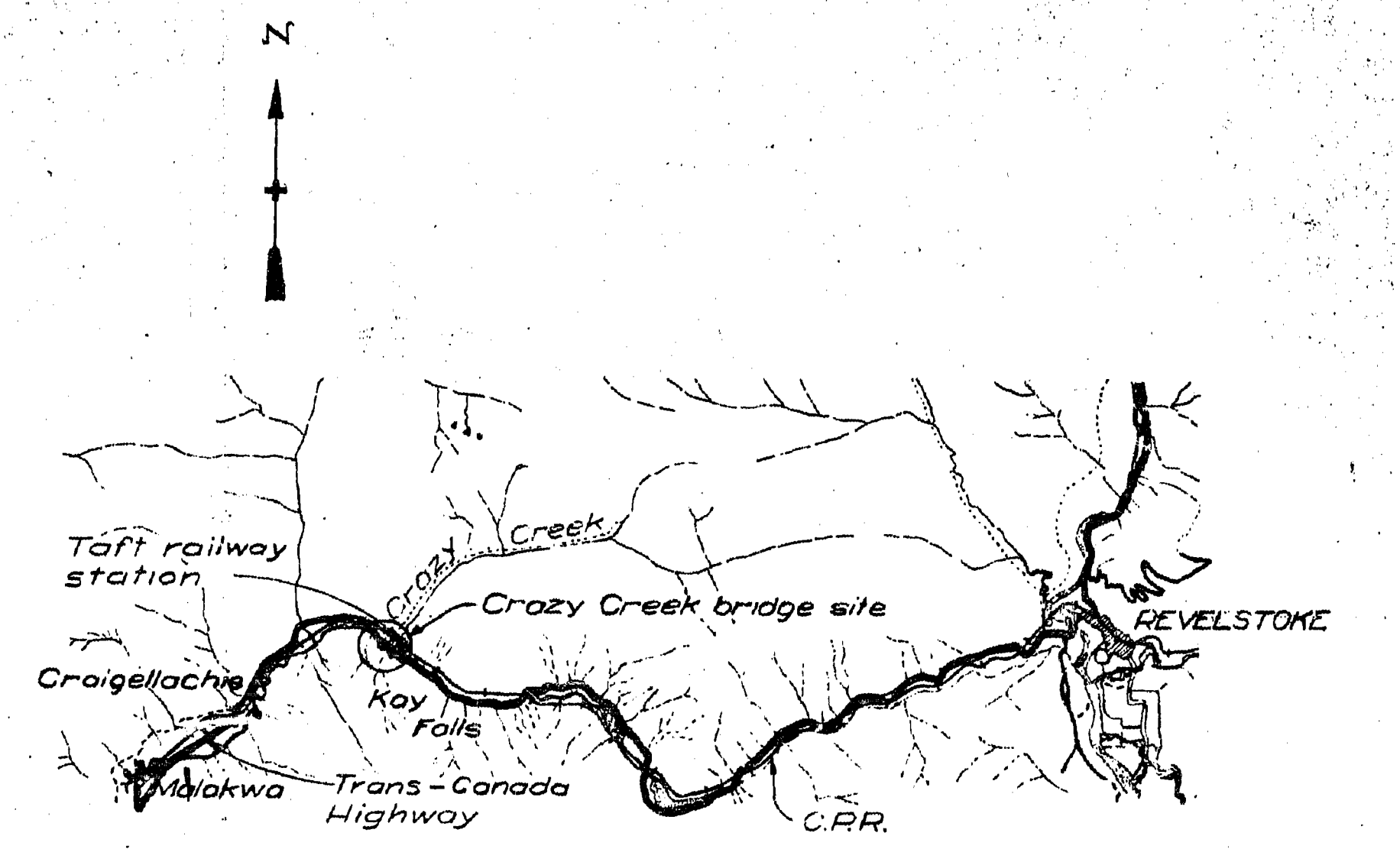

KEY PLAN  
Scale 1" = 4 Miles

OFFICE COPY

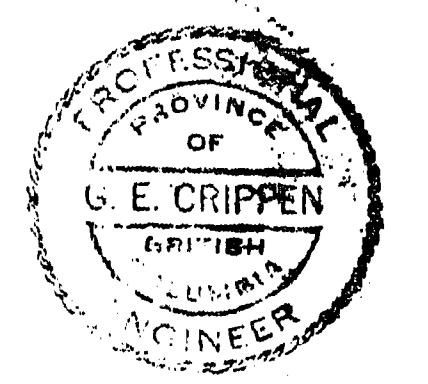

Scale as noted

BRITISH COLUMBIA DEPARTMENT OF HIGHWAYS	
CRAZY CREEK BRIDGE SITE PLAN & PROFILE	
100449	
CRIPPEN WRIGHT ENGINEERING LTD.	
DESIGN: _____	SUBMITTED: <i>G. E. Crrippen</i>
DRAWN: MP	RECOMMENDED: _____
CHECKED: _____	APPROVED: <i>G. E. Crrippen</i>
REV. NO.	VANCOUVER, B. C.
1	DATE April 4, 1957.
2	DRAWING NO. BRIDGES 1524-1
3	
4	

**APPENDIX B**  
**PRELIMINARY MITIGATION DESIGN (ISSUED FOR PERMITTING**  
**FEBRUARY 22, 2023)**



**CRAZY CREEK BRIDGE NO. 01524 SCOUR REMEDIATION  
INDEX**

DRAWING NO.	DRAWING TITLE	REVISION	DATE ISSUED
01	INDEX	A	FEBRUARY 21, 2023
02	PLAN	C	FEBRUARY 21, 2023
03	CROSS-SECTIONS A AND B	C	FEBRUARY 21, 2023
04	CROSS-SECTIONS C AND DETAIL	C	FEBRUARY 21, 2023

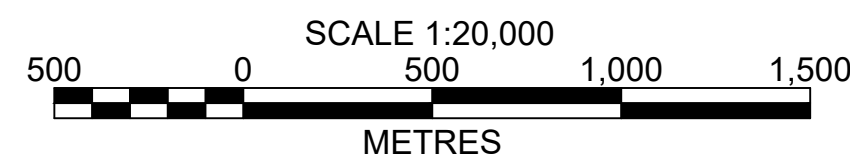

PLOT DATE: 2023-02-21 C:\\_BIM\AC\Des\BGC BIM Account\0272-CRAZY\_CREEK-CAD\Project Files\Production\Report-Memo\20210304-CRAZY\_CREEK-MITIGATION\01.dwg

- NOTES:**
- ALL DIMENSIONS ARE IN METRES UNLESS OTHERWISE NOTED.
  - AIR PHOTO SOURCE: ESRI WORLD IMAGERY, DATED OCTOBER 5, 2010.
  - UNLESS BGC AGREES OTHERWISE IN WRITING, THIS DRAWING SHALL NOT BE MODIFIED OR USED FOR ANY PURPOSE OTHER THAN THE PURPOSE FOR WHICH BGC GENERATED IT. BGC SHALL HAVE NO LIABILITY FOR ANY DAMAGES OR LOSS ARISING IN ANY WAY FROM ANY USE OR MODIFICATION OF THIS DOCUMENT NOT AUTHORIZED BY BGC. ANY USE OF OR RELIANCE UPON THIS DOCUMENT OR ITS CONTENT BY THIRD PARTIES SHALL BE AT SUCH THIRD PARTIES' SOLE RISK.

**ISSUED FOR PERMITTING**  
**NOT FOR CONSTRUCTION**

THIS DRAWING MAY HAVE BEEN REDUCED OR ENLARGED.  
ALL FRACTIONAL SCALE NOTATIONS INDICATED ARE  
BASED ON ORIGINAL FORMAT DRAWINGS.

SCALE AS SHOWN		CAD FILENAME 01 PLOT DATE 2023-02-21	
REV	DATE	REVISIONS	NAME
A	2023-02-21	ISSUED FOR PERMITTING	KH
KATHLEEN HORITA, P. ENG. SENIOR DESIGNER		DESIGNED KH DATE 2023-02-21 QUALITY CONTROL HVH DATE 2023-02-21 QUALITY ASSURANCE HW DATE 2023-02-21 DRAWN AL DATE 2023-02-21	
DATE 2023-02-21	FILE NUMBER -	PROJECT NUMBER 26127-2023	REG -
		DRAWING NUMBER 01	REV A



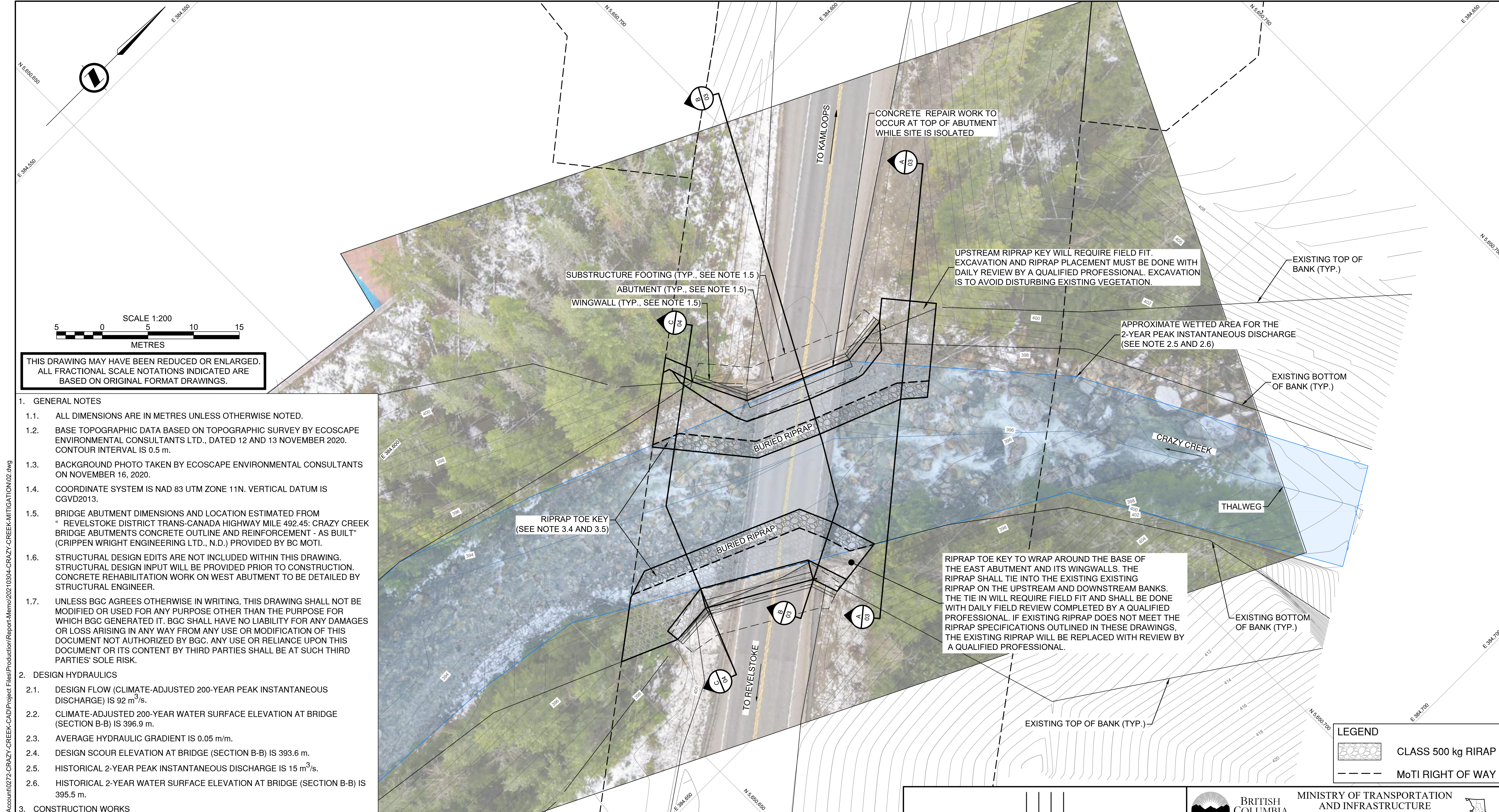

THIS DRAWING MAY HAVE BEEN REDUCED OR ENLARGED.  
ALL FRACTIONAL SCALE NOTATIONS INDICATED ARE  
BASED ON ORIGINAL FORMAT DRAWINGS.

- 1. GENERAL NOTES**
- 1.1. ALL DIMENSIONS ARE IN METRES UNLESS OTHERWISE NOTED.
  - 1.2. BASE TOPOGRAPHIC DATA BASED ON TOPOGRAPHIC SURVEY BY ECOSCAPE ENVIRONMENTAL CONSULTANTS LTD., DATED 12 AND 13 NOVEMBER 2020. CONTOUR INTERVAL IS 0.5 m.
  - 1.3. BACKGROUND PHOTO TAKEN BY ECOSCAPE ENVIRONMENTAL CONSULTANTS ON NOVEMBER 16, 2020.
  - 1.4. COORDINATE SYSTEM IS NAD 83 UTM ZONE 11N. VERTICAL DATUM IS CGVD2013.
  - 1.5. BRIDGE ABUTMENT DIMENSIONS AND LOCATION ESTIMATED FROM "REVELSTOKE DISTRICT TRANS-CANADA HIGHWAY MILE 492.45: CRAZY CREEK BRIDGE ABUTMENTS CONCRETE OUTLINE AND REINFORCEMENT - AS BUILT" (CRIPPEN WRIGHT ENGINEERING LTD., N.D.) PROVIDED BY BC MOTI.
  - 1.6. STRUCTURAL DESIGN EDITS ARE NOT INCLUDED WITHIN THIS DRAWING. STRUCTURAL DESIGN INPUT WILL BE PROVIDED PRIOR TO CONSTRUCTION. CONCRETE REHABILITATION WORK ON WEST ABUTMENT TO BE DETAILED BY STRUCTURAL ENGINEER.
  - 1.7. UNLESS BGC AGREES OTHERWISE IN WRITING, THIS DRAWING SHALL NOT BE MODIFIED OR USED FOR ANY PURPOSE OTHER THAN THE PURPOSE FOR WHICH BGC GENERATED IT. BGC SHALL HAVE NO LIABILITY FOR ANY DAMAGES OR LOSS ARISING IN ANY WAY FROM ANY USE OR MODIFICATION OF THIS DOCUMENT NOT AUTHORIZED BY BGC. ANY USE OR RELIANCE UPON THIS DOCUMENT OR ITS CONTENT BY THIRD PARTIES SHALL BE AT SUCH THIRD PARTIES' SOLE RISK.
- 2. DESIGN HYDRAULICS**
- 2.1. DESIGN FLOW (CLIMATE-ADJUSTED 200-YEAR PEAK INSTANTANEOUS DISCHARGE) IS 92 m<sup>3</sup>/s.
  - 2.2. CLIMATE-ADJUSTED 200-YEAR WATER SURFACE ELEVATION AT BRIDGE (SECTION B-B) IS 396.9 m.
  - 2.3. AVERAGE HYDRAULIC GRADIENT IS 0.05 m/m.
  - 2.4. DESIGN SCOUR ELEVATION AT BRIDGE (SECTION B-B) IS 393.6 m.
  - 2.5. HISTORICAL 2-YEAR PEAK INSTANTANEOUS DISCHARGE IS 15 m<sup>3</sup>/s.
  - 2.6. HISTORICAL 2-YEAR WATER SURFACE ELEVATION AT BRIDGE (SECTION B-B) IS 395.5 m.
- 3. CONSTRUCTION WORKS**
- 3.1. THIS PROJECT SHALL CONFORM TO THE BC MINISTRY OF TRANSPORTATION AND INFRASTRUCTURE 2020 STANDARD SPECIFICATIONS FOR HIGHWAY CONSTRUCTION.
  - 3.2. ENVIRONMENTAL MANAGEMENT SHALL CONFORM TO STANDARD SPECIFICATIONS 165.  
HYDRAULIC ISOLATION OF THE WORK AREA SHALL BE ESTABLISHED PRIOR TO ANY INSTREAM WORKS. CONSTRUCTION AND EXCAVATION IS TO PROCEED IN THE DRY AND IN ISOLATION FROM FLOWING WATERS.
  - 3.4. THE DESIGN SCOUR ELEVATION VARIES. THE DESIGN SCOUR ELEVATION SHALL BE MEASURED AT THE BRIDGE (SECTION B-B) AND WILL INCREASE MOVING UPSTREAM FOLLOWING THE SPECIFIED AVERAGE HYDRAULIC GRADIENT AND SIMILARLY DECREASE MOVING DOWNSTREAM. ADJACENT TO THE BRIDGE STRUCTURE, THE RIPRAP IS TO BE INSTALLED A MINIMUM OF 1.5 m BELOW THE TOP OF THE FOOTINGS.

- 3.5. EXCAVATION OF THE RIPRAP TOE TRENCH SHALL BE DONE WITH DAILY FIELD REVIEW DONE BY A QUALIFIED PROFESSIONAL. THE SIDE SLOPES OF THE EXCAVATION MUST NOT EXCEED 1.5H:1V.
- 3.6. RIPRAP SHALL BE CLASS 500 kg. RIPRAP QUALITY CONTROL, SPECIFICATION, AND INSTALLATION SHALL CONFORM TO STANDARD SPECIFICATIONS SECTION 205.
- 3.7. ALL RIPRAP AGAINST THE CHANNEL BANKS TO BE UNDERLAIN WITH NON-WOVEN GEOTEXTILE. RIPRAP TO BE KEYED INTO THE SLOPE AT THE UPSLOPE END AS SHOWN. GEOTEXTILE SHALL BE MIRAFI 1100N OR APPROVED EQUIVALENT.
- 3.8. EXCAVATED MATERIAL TO BE RETURNED TO THE CHANNEL TO RE-ESTABLISH THE ORIGINAL GROUND SURFACE, EXCESS MATERIAL CAN ALSO BE USED TO FILL IN THE RIPRAP VOIDS AT THE DIRECTION OF A QUALIFIED PROFESSIONAL.

**ISSUED FOR PERMITTING**  
**NOT FOR CONSTRUCTION**

**LEGEND**

- CLASS 500 kg RIRAP
- MoTI RIGHT OF WAY

<b>BGC</b>		<b>BRITISH COLUMBIA</b> MINISTRY OF TRANSPORTATION AND INFRASTRUCTURE SOUTHERN INTERIOR REGION HIGHWAY ENGINEERING AND GEOMATICS																	
SCALE  0 2 1:200 10m CAD FILENAME: 02 PLOT DATE: 2023-02-21		<b>PLAN</b> <b>CRAZY CREEK BRIDGE NO. 01524</b> <b>SCOUR REMEDIATION</b>																	
<table border="1"> <thead> <tr> <th>REV</th> <th>DATE</th> <th>REVISIONS</th> <th>NAME</th> </tr> </thead> <tbody> <tr> <td>A</td> <td>2021-03-19</td> <td>ISSUED FOR REVIEW</td> <td>KH</td> </tr> <tr> <td>B</td> <td>2021-05-17</td> <td>ISSUED FOR REVIEW</td> <td>KH</td> </tr> <tr> <td>C</td> <td>2023-02-21</td> <td>ISSUED FOR PERMITTING</td> <td>KH</td> </tr> </tbody> </table>	REV	DATE	REVISIONS	NAME	A	2021-03-19	ISSUED FOR REVIEW	KH	B	2021-05-17	ISSUED FOR REVIEW	KH	C	2023-02-21	ISSUED FOR PERMITTING	KH	DESIGNED: <u>          KH          </u> DATE: <u>2023-02-21</u> QUALITY CONTROL: <u>          HVH          </u> DATE: <u>2023-02-21</u> QUALITY ASSURANCE: <u>          HW          </u> DATE: <u>2023-02-21</u> DRAWN: <u>          AL          </u> DATE: <u>2023-02-21</u>		KATHLEEN HORITA, P. ENG. SENIOR DESIGNER
REV	DATE	REVISIONS	NAME																
A	2021-03-19	ISSUED FOR REVIEW	KH																
B	2021-05-17	ISSUED FOR REVIEW	KH																
C	2023-02-21	ISSUED FOR PERMITTING	KH																
DATE: 2023-02-21 FILE NUMBER: - PROJECT NUMBER: 26127-2023 REG: - DRAWING NUMBER: 02 REV: C																			

PLOT DATE: 2023/02/22 C:\\_BIM\AC\Docs\BGC BIM Account\0272-CRAZY-CREEK-CAD\Project\Report\Memo\20210304-CRAZY-CREEK-MITIGATION\02.dwg



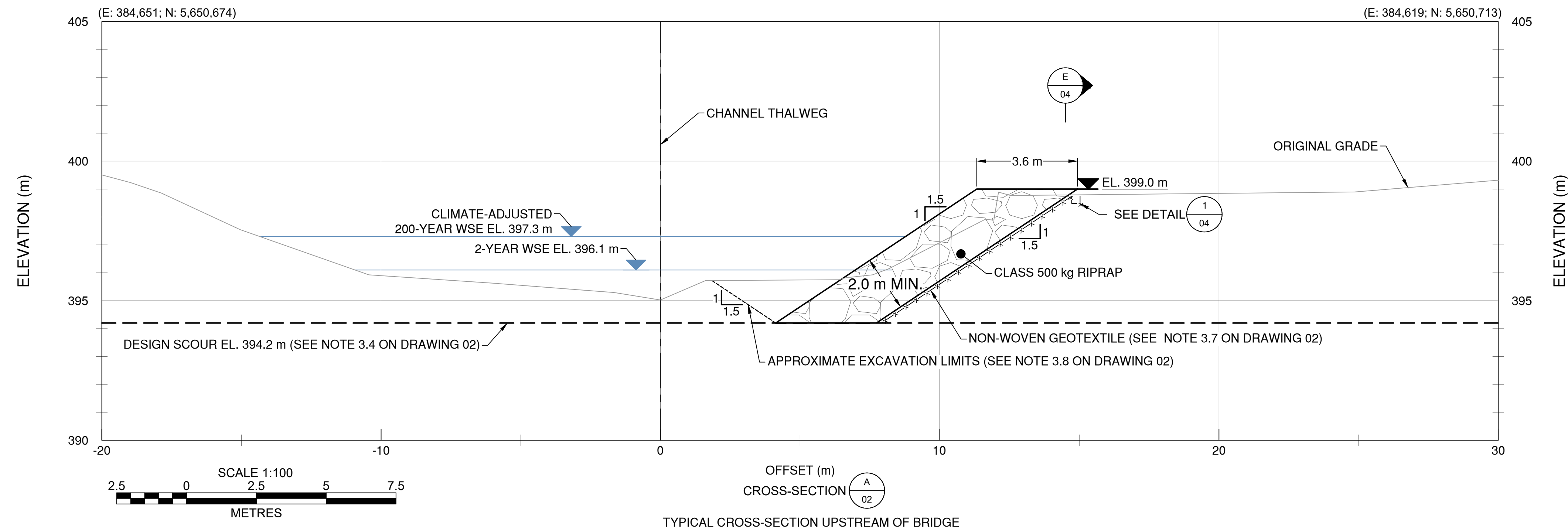

TYPICAL CROSS-SECTION UPSTREAM OF BRIDGE

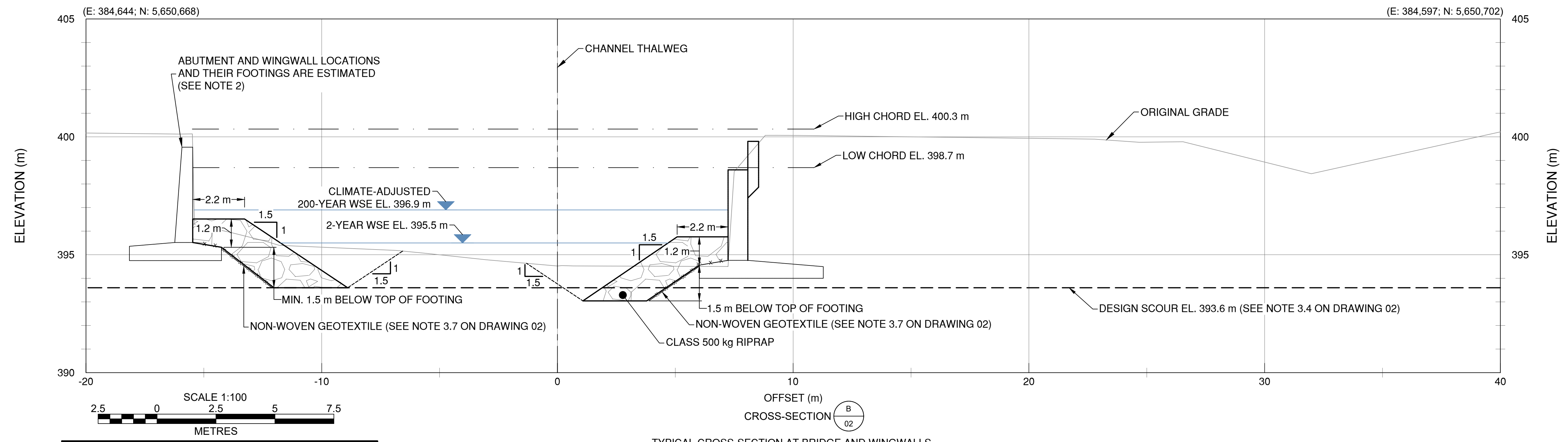

TYPICAL CROSS-SECTION AT BRIDGE AND WINGWALLS

THIS DRAWING MAY HAVE BEEN REDUCED OR ENLARGED. ALL FRACTIONAL SCALE NOTATIONS INDICATED ARE BASED ON ORIGINAL FORMAT DRAWINGS.

THIS DRAWING MAY HAVE BEEN REDUCED OR ENLARGED. ALL FRACTIONAL SCALE NOTATIONS INDICATED ARE BASED ON ORIGINAL FORMAT DRAWINGS.

- GENERAL NOTES:
- ALL DIMENSIONS ARE IN METRES UNLESS OTHERWISE NOTED.
  - BRIDGE ABUTMENT DIMENSIONS AND LOCATION ESTIMATED FROM " REVELSTOKE DISTRICT TRANS-CANADA HIGHWAY MILE 492.45: CRAZY CREEK BRIDGE ABUTMENTS CONCRETE OUTLINE AND REINFORCEMENT - AS BUILT" (CRIPPEN WRIGHT ENGINEERING LTD., N.D.) PROVIDED BY BC MOTI.
  - STRUCTURAL DESIGN EDITS ARE NOT INCLUDED WITHIN THIS DRAWING. STRUCTURAL DESIGN INPUT WILL BE PROVIDED PRIOR TO CONSTRUCTION.
  - UNLESS BGC AGREES OTHERWISE IN WRITING, THIS DRAWING SHALL NOT BE MODIFIED OR USED FOR ANY PURPOSE OTHER THAN THE PURPOSE FOR WHICH BGC GENERATED IT. BGC SHALL HAVE NO LIABILITY FOR ANY DAMAGES OR LOSS ARISING IN ANY WAY FROM ANY USE OR MODIFICATION OF THIS DOCUMENT NOT AUTHORIZED BY BGC. ANY USE OR RELIANCE UPON THIS DOCUMENT OR ITS CONTENT BY THIRD PARTIES SHALL BE AT SUCH THIRD PARTIES' SOLE RISK.

ISSUED FOR PERMITTING  
NOT FOR CONSTRUCTION

<b>BGC</b>		BRITISH COLUMBIA		MINISTRY OF TRANSPORTATION AND INFRASTRUCTURE SOUTHERN INTERIOR REGION HIGHWAY ENGINEERING AND GEOMATICS	
SCALE 0 1 1:100 5m		CAD FILENAME: 03		PLOT DATE: 2023-02-21	
<b>CROSS-SECTIONS A AND B</b> CRAZY CREEK BRIDGE NO. 01524 SCOUR REMEDIATION		DESIGNED: KH DATE: 2023-02-21 QUALITY CONTROL: HVH DATE: 2023-02-21 QUALITY ASSURANCE: HW DATE: 2023-02-21 DRAWN: AL DATE: 2023-02-21		SENIOR DESIGNER: <b>KATHLEEN HORITA, P. ENG.</b> DATE: 2023-02-21	
FILE NUMBER: -		PROJECT NUMBER: 26127-2023		REG: - DRAWING NUMBER: 03	

PLOT DATE: 2023-02-21 C:\BIM\ACC\Docs\BGC BIM Account\0272-CRAZY-CREEK-CAD\Project Files\Production\Report\Memo\20210304-CRAZY-CREEK-MITIGATION\03.dwg

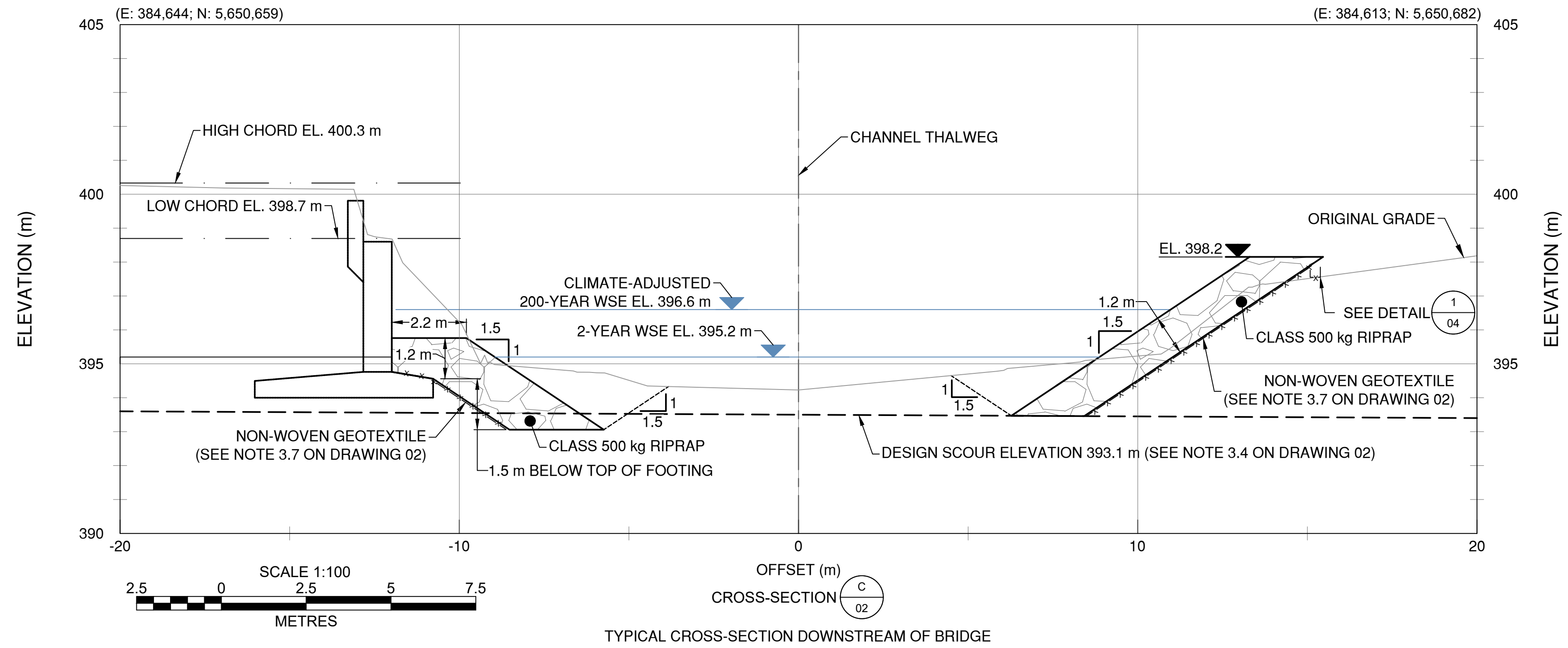

TYPICAL CROSS-SECTION DOWNSTREAM OF BRIDGE

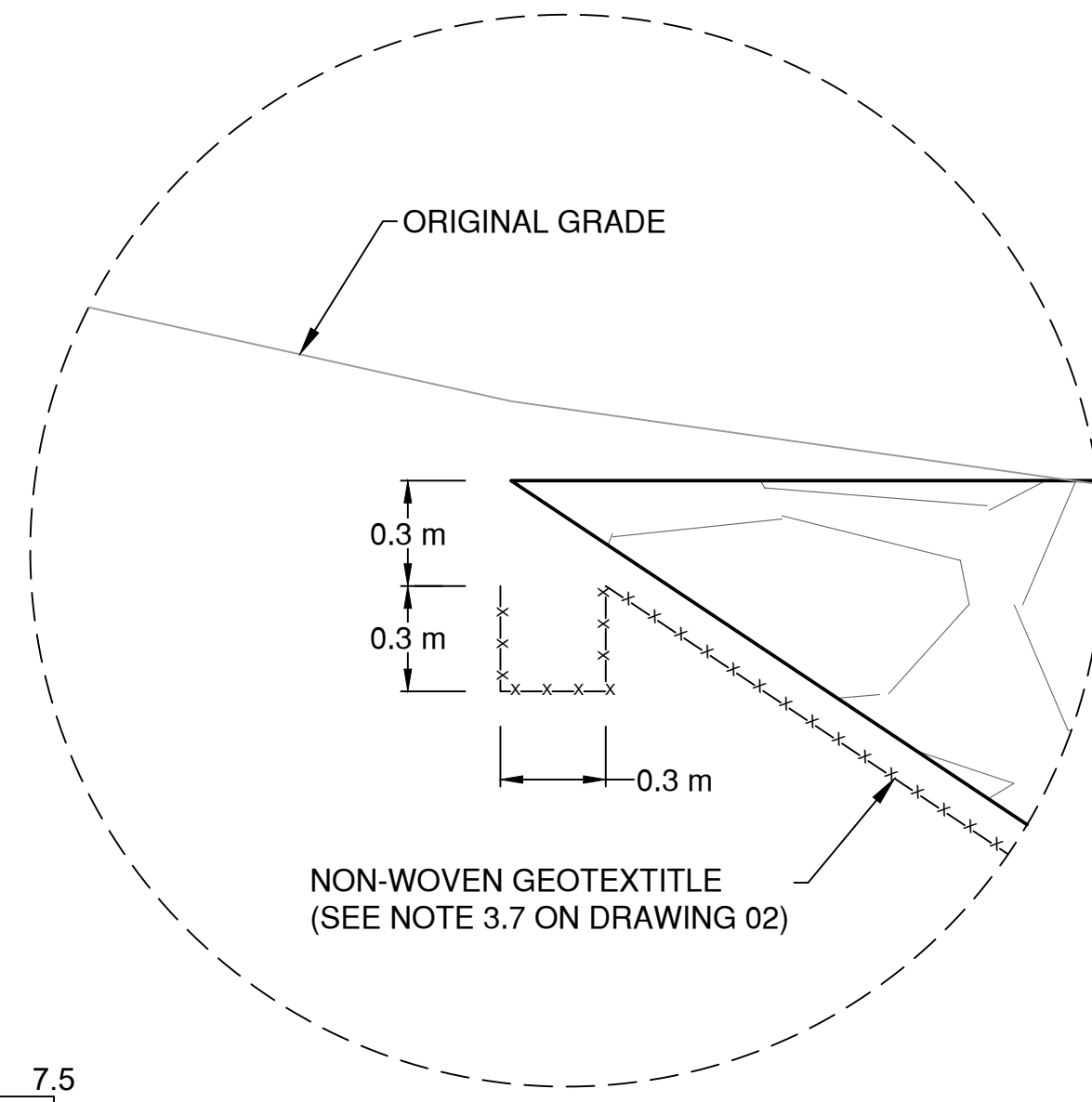

TYPICAL NON-WOVEN GEOTEXTILE UPSLOPE KEY-IN

THIS DRAWING MAY HAVE BEEN REDUCED OR ENLARGED. ALL FRACTIONAL SCALE NOTATIONS INDICATED ARE BASED ON ORIGINAL FORMAT DRAWINGS.

THIS DRAWING MAY HAVE BEEN REDUCED OR ENLARGED. ALL FRACTIONAL SCALE NOTATIONS INDICATED ARE BASED ON ORIGINAL FORMAT DRAWINGS.

GENERAL NOTES:

- ALL DIMENSIONS ARE IN METRES UNLESS OTHERWISE NOTED.
- BRIDGE ABUTMENT DIMENSIONS AND LOCATION ESTIMATED FROM " REVELSTOKE DISTRICT TRANS-CANADA HIGHWAY MILE 492.45: CRAZY CREEK BRIDGE ABUTMENTS CONCRETE OUTLINE AND REINFORCEMENT - AS BUILT" (CRIPPEN WRIGHT ENGINEERING LTD., N.D.) PROVIDED BY BC MOTI.
- STRUCTURAL DESIGN EDITS ARE NOT INCLUDED WITHIN THIS DRAWING. STRUCTURAL DESIGN INPUT WILL BE PROVIDED PRIOR TO CONSTRUCTION.
- UNLESS BGC AGREES OTHERWISE IN WRITING, THIS DRAWING SHALL NOT BE MODIFIED OR USED FOR ANY PURPOSE OTHER THAN THE PURPOSE FOR WHICH BGC GENERATED IT. BGC SHALL HAVE NO LIABILITY FOR ANY DAMAGES OR LOSS ARISING IN ANY WAY FROM ANY USE OR MODIFICATION OF THIS DOCUMENT NOT AUTHORIZED BY BGC. ANY USE OR RELIANCE UPON THIS DOCUMENT OR ITS CONTENT BY THIRD PARTIES SHALL BE AT SUCH THIRD PARTIES' SOLE RISK.

ISSUED FOR PERMITTING

NOT FOR CONSTRUCTION

<b>BGC</b>		BRITISH COLUMBIA		MINISTRY OF TRANSPORTATION AND INFRASTRUCTURE SOUTHERN INTERIOR REGION HIGHWAY ENGINEERING AND GEOMATICS	
SCALE 0 1 1:100 5m CAD FILENAME: 04 PLOT DATE: 2023-02-21		<b>CROSS-SECTIONS C AND DETAIL</b> CRAZY CREEK BRIDGE NO. 01524 SCOUR REMEDIATION			
REV	DATE	REVISIONS	NAME	DESIGNED	KH DATE 2023-02-21
A	2021-03-19	ISSUED FOR REVIEW	KH	QUALITY CONTROL	HVH DATE 2023-02-21
B	2021-05-17	ISSUED FOR REVIEW	KH	QUALITY ASSURANCE	HW DATE 2023-02-21
C	2023-02-21	ISSUED FRO PERMITTING	KH	DRAWN	AL DATE 2023-02-21
			KATHLEEN HORITA, P. ENG. SENIOR DESIGNER		
DATE 2023-02-21		PROJECT NUMBER 26127-2023		REG -	DRAWING NUMBER 04
					REV C

PLOT DATE: 2023-02-21 C:\\_BIM\ACC\Docs\BGC BIM Account\0272-CRAZY-CREEK-CAD\Project\_Files\Production\Report\Memo\20210304-CRAZY-CREEK-MITIGATION\04.dwg



## **APPENDIX C STABILITY RESULTS**

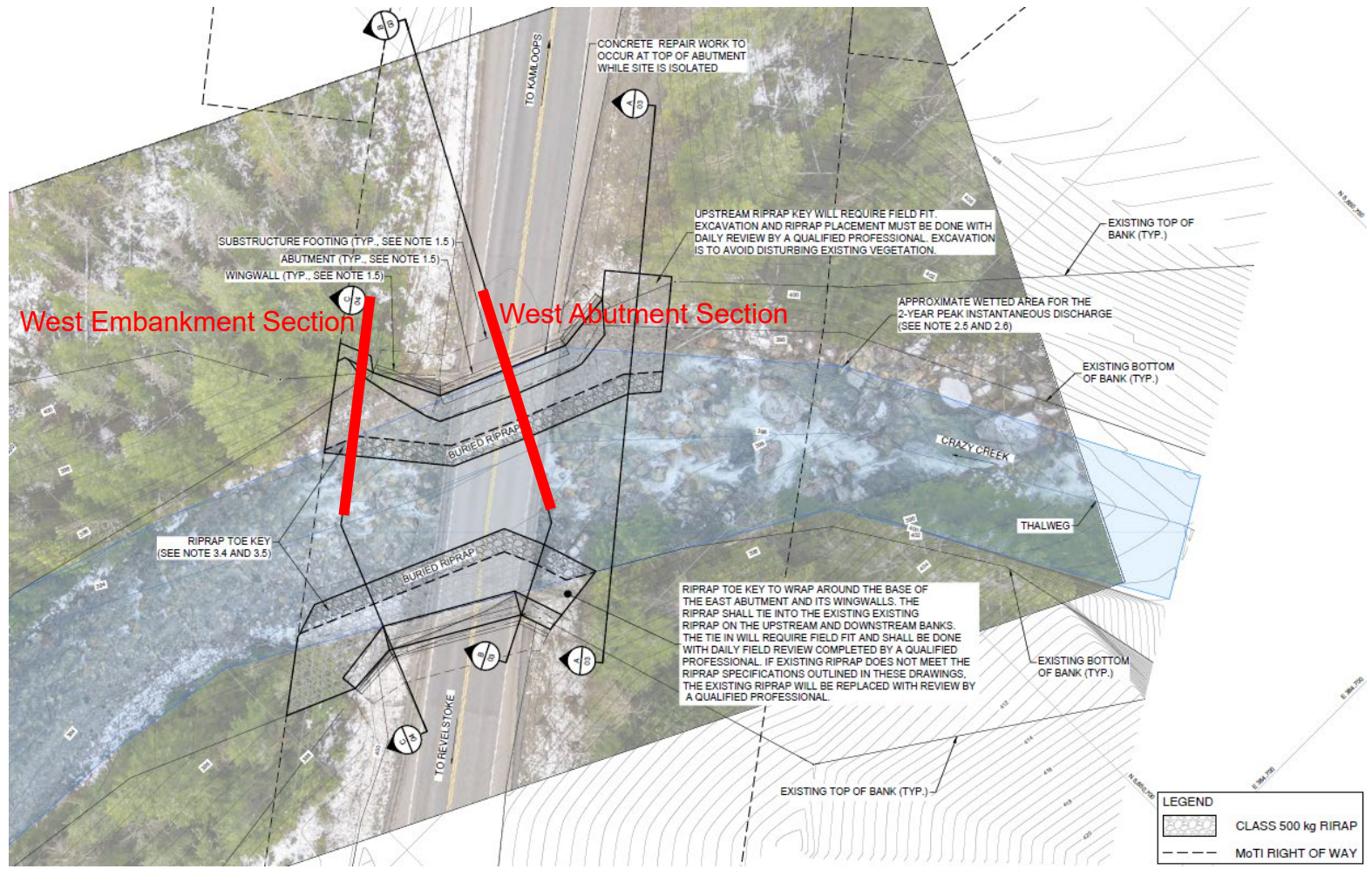

NOTES

1. THIS FIGURE SHOULD BE READ IN CONJUNCTION WITH BGC'S REPORT TITLED "CRAZY CREEK BRIDGE – PRELIMINARY GEOTECHNICAL ASSESSMENT OF SCOUR AND EROSION MITIGATION WORK" AND DATED JUNE 2023.
2. MITIGATION PERMITTING DESIGN BY BGC (CRAZY CREEK BRIDGE NO. 01524) AND DATED FEBRUARY 22, 2023, DRAWINGS PROVIDED IN APPENDIX B OF THIS REPORT.

PREPARED BY: <b>IKP</b>	FIGURE TITLE: <b>PLAN VIEW – LOCATION OF STABILITY SECTIONS</b>		
CHECKED BY: <b>LM</b>	CLIENT: <b>BRITISH COLUMBIA MINISTRY OF TRANSPORTATION AND INFRASTRUCTURE</b>		
APPROVED BY: <b>IKP</b>	SCALE: <b>NTS</b>	PROJECT NO: <b>0272102</b>	FIGURE NO: <b>C-1</b>

0 5 10 mm in ANSI A sized paper

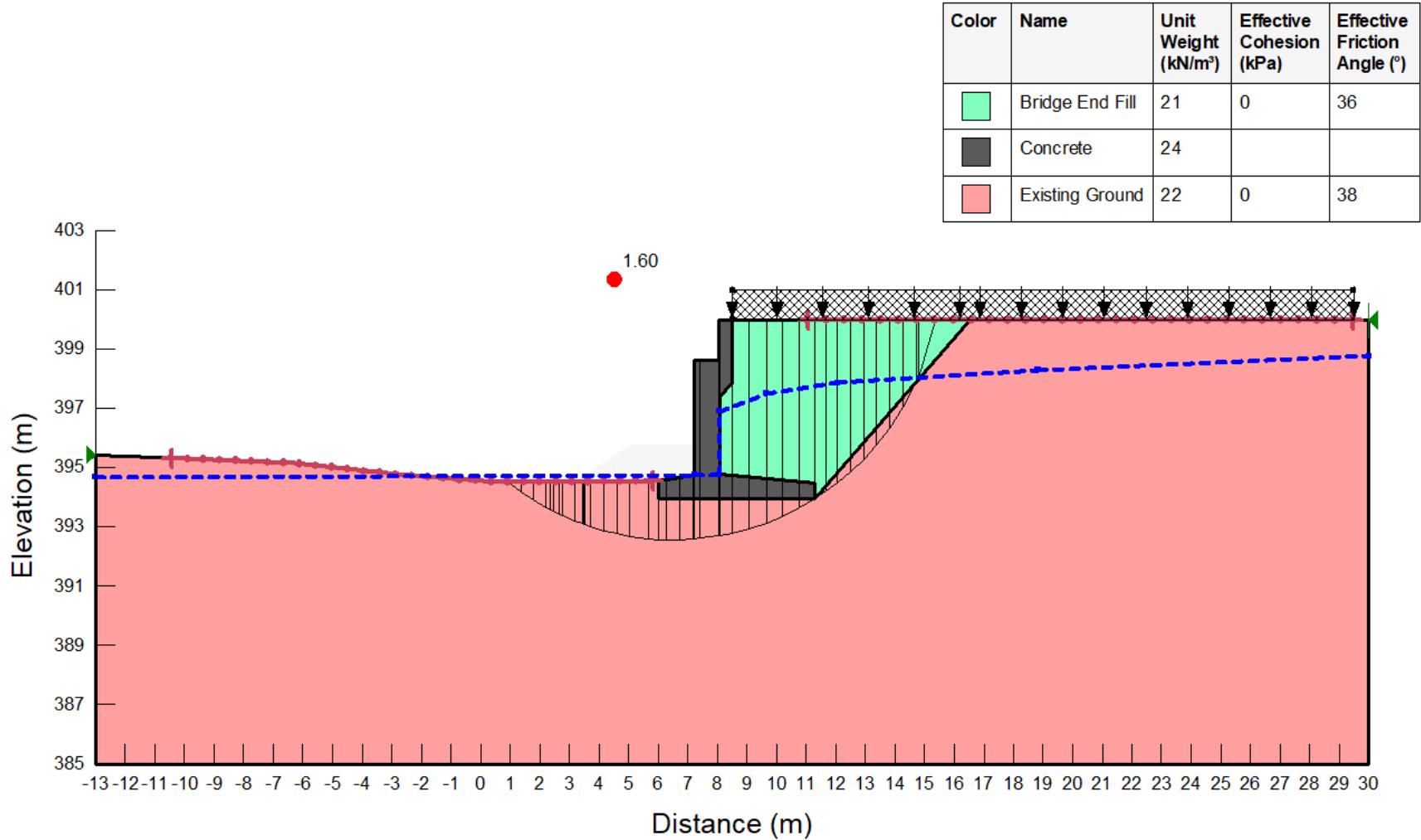

NOTES

1. THIS FIGURE SHOULD BE READ IN CONJUNCTION WITH BGC'S REPORT TITLED "CRAZY CREEK BRIDGE – PRELIMINARY GEOTECHNICAL ASSESSMENT OF SCOUR AND EROSION MITIGATION WORK" AND DATED JUNE 2023.
2. MITIGATION PERMITTING DESIGN BY BGC (CRAZY CREEK BRIDGE NO. 01524) AND DATED FEBRUARY 22, 2023, DRAWINGS PROVIDED IN APPENDIX B OF THIS REPORT.
3. THE SECTION SHOWS THE CONCEPTUAL GEOLOGICAL INTERPRETATION BASED ON THE AVAILABLE INFORMATION AND BOUNDARIES BETWEEN MATERIAL UNITS SHOULD BE CONSIDERED APPROXIMATE.
4. A 20 KPA TRAFFIC SURCHARGE LOAD HAS BEEN APPLIED TO THE HIGHWAY 1 APPROACH.

PREPARED BY: <b>IKP</b>	FIGURE TITLE: <b>CASE 1 – WEST ABUTMENT EXISTING CONDITIONS</b>		
CHECKED BY: <b>LM</b>	CLIENT: <b>BRITISH COLUMBIA MINISTRY OF TRANSPORTATION AND INFRASTRUCTURE</b>		
APPROVED BY: <b>IKP</b>	SCALE: <b>NTS</b>	PROJECT NO: <b>0272102</b>	FIGURE NO: <b>C-2</b>

0 5 10 mm in ANSI A sized paper

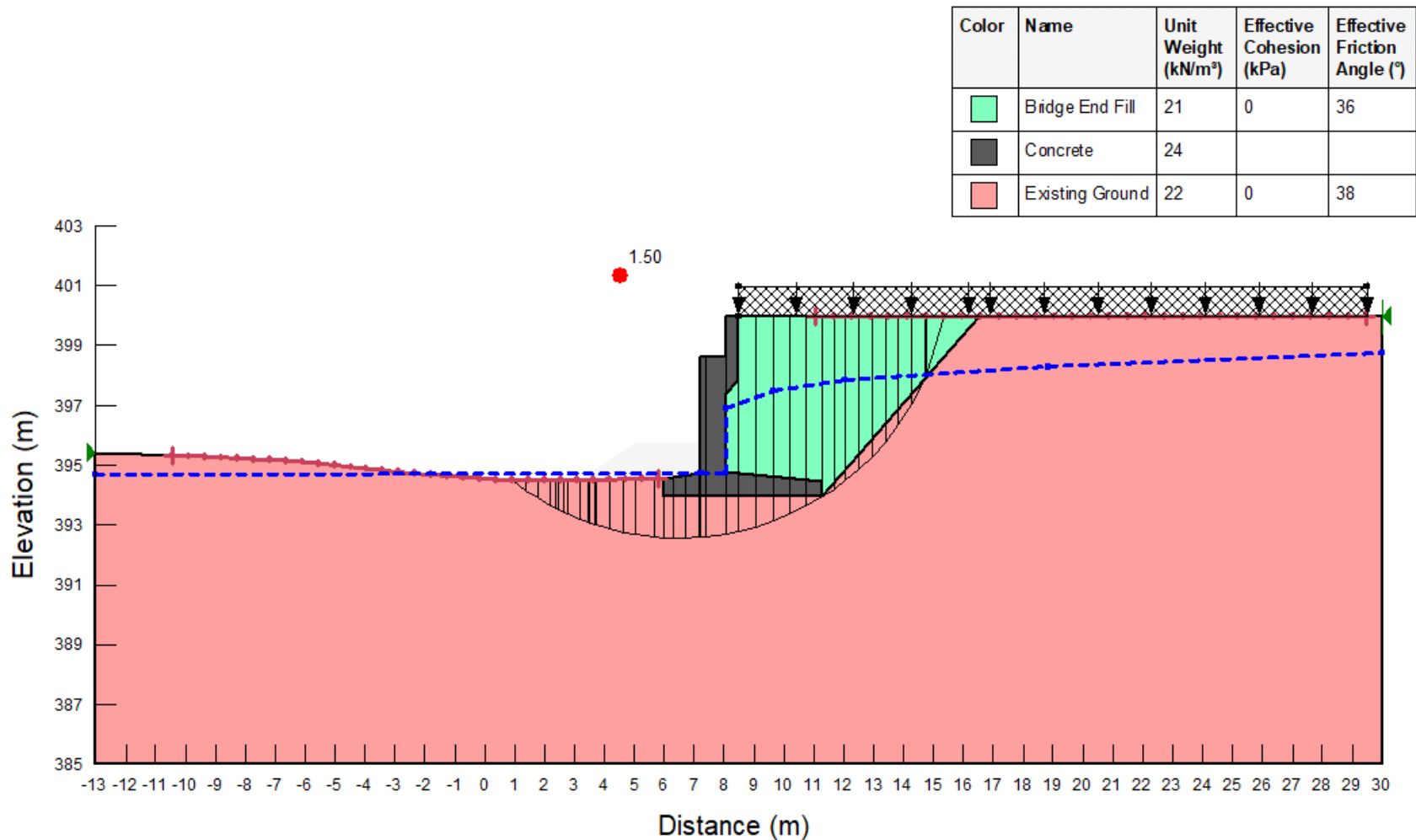

NOTES

1. THIS FIGURE SHOULD BE READ IN CONJUNCTION WITH BGC'S REPORT TITLED "CRAZY CREEK BRIDGE – PRELIMINARY GEOTECHNICAL ASSESSMENT OF SCOUR AND EROSION MITIGATION WORK" AND DATED JUNE 2023.
2. MITIGATION PERMITTING DESIGN BY BGC (CRAZY CREEK BRIDGE NO. 01524) AND DATED FEBRUARY 22, 2023, DRAWINGS PROVIDED IN APPENDIX B OF THIS REPORT.
3. THE SECTION SHOWS THE CONCEPTUAL GEOLOGICAL INTERPRETATION BASED ON THE AVAILABLE INFORMATION AND BOUNDARIES BETWEEN MATERIAL UNITS SHOULD BE CONSIDERED APPROXIMATE.
4. A 20 KPA TRAFFIC SURCHARGE LOAD HAS BEEN APPLIED TO THE HIGHWAY 1 APPROACH.
5. THE PSEUDO STATIC ANALYSIS (PSA) ABOVE IS SHOWN FOR HORIZONTAL PGA (PEAK GROUND ACCELERATION) OF 0.045 G BASED ON A 975-YEAR RETURN PERIOD SITE CLASS C.

PREPARED BY: <b>IKP</b>	FIGURE TITLE: <b>CASE 2 – WEST ABUTMENT EXISTING CONDITIONS (SEISMIC)</b>		
CHECKED BY: <b>LM</b>	CLIENT: <b>BRITISH COLUMBIA MINISTRY OF TRANSPORTATION AND INFRASTRUCTURE</b>		
APPROVED BY: <b>IKP</b>	SCALE: <b>NTS</b>	PROJECT NO: <b>0272102</b>	FIGURE NO: <b>C-3</b>

0 5 10 mm in ANSI A sized paper

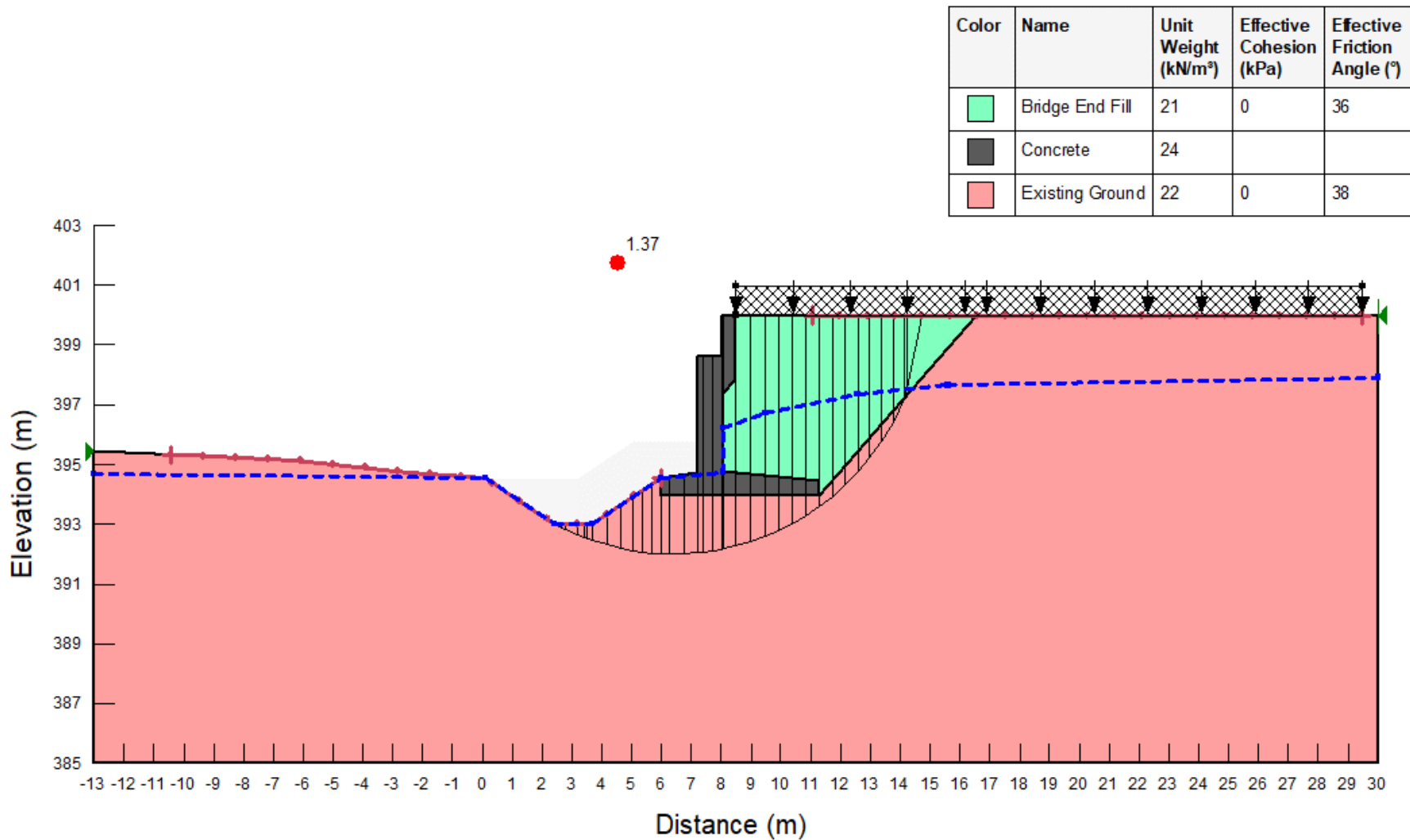

NOTES

1. THIS FIGURE SHOULD BE READ IN CONJUNCTION WITH BGC'S REPORT TITLED "CRAZY CREEK BRIDGE – PRELIMINARY GEOTECHNICAL ASSESSMENT OF SCOUR AND EROSION MITIGATION WORK" AND DATED JUNE 2023.
2. MITIGATION PERMITTING DESIGN BY BGC (CRAZY CREEK BRIDGE NO. 01524) AND DATED FEBRUARY 22, 2023, DRAWINGS PROVIDED IN APPENDIX B OF THIS REPORT.
3. THE SECTION SHOWS THE CONCEPTUAL GEOLOGICAL INTERPRETATION BASED ON THE AVAILABLE INFORMATION AND BOUNDARIES BETWEEN MATERIAL UNITS SHOULD BE CONSIDERED APPROXIMATE.
4. A 20 KPA TRAFFIC SURCHARGE LOAD HAS BEEN APPLIED TO THE HIGHWAY 1 APPROACH. A SLIGHTLY LOW PIEZOMETRIC SURFACE THAN EXISTING CONDITIONS (CASE 1) HAS BEEN USED

PREPARED BY: <b>IKP</b>	FIGURE TITLE: <b>CASE 3 – WEST ABUTMENT RIPRAP EXCAVATION (TEMPORARY)</b>		
CHECKED BY: <b>LM</b>	CLIENT: <b>BRITISH COLUMBIA MINISTRY OF TRANSPORTATION AND INFRASTRUCTURE</b>		
APPROVED BY: <b>IKP</b>	SCALE: <b>NTS</b>	PROJECT NO: <b>0272102</b>	FIGURE NO: <b>C-4</b>

0 5 10 mm in ANSI A sized paper

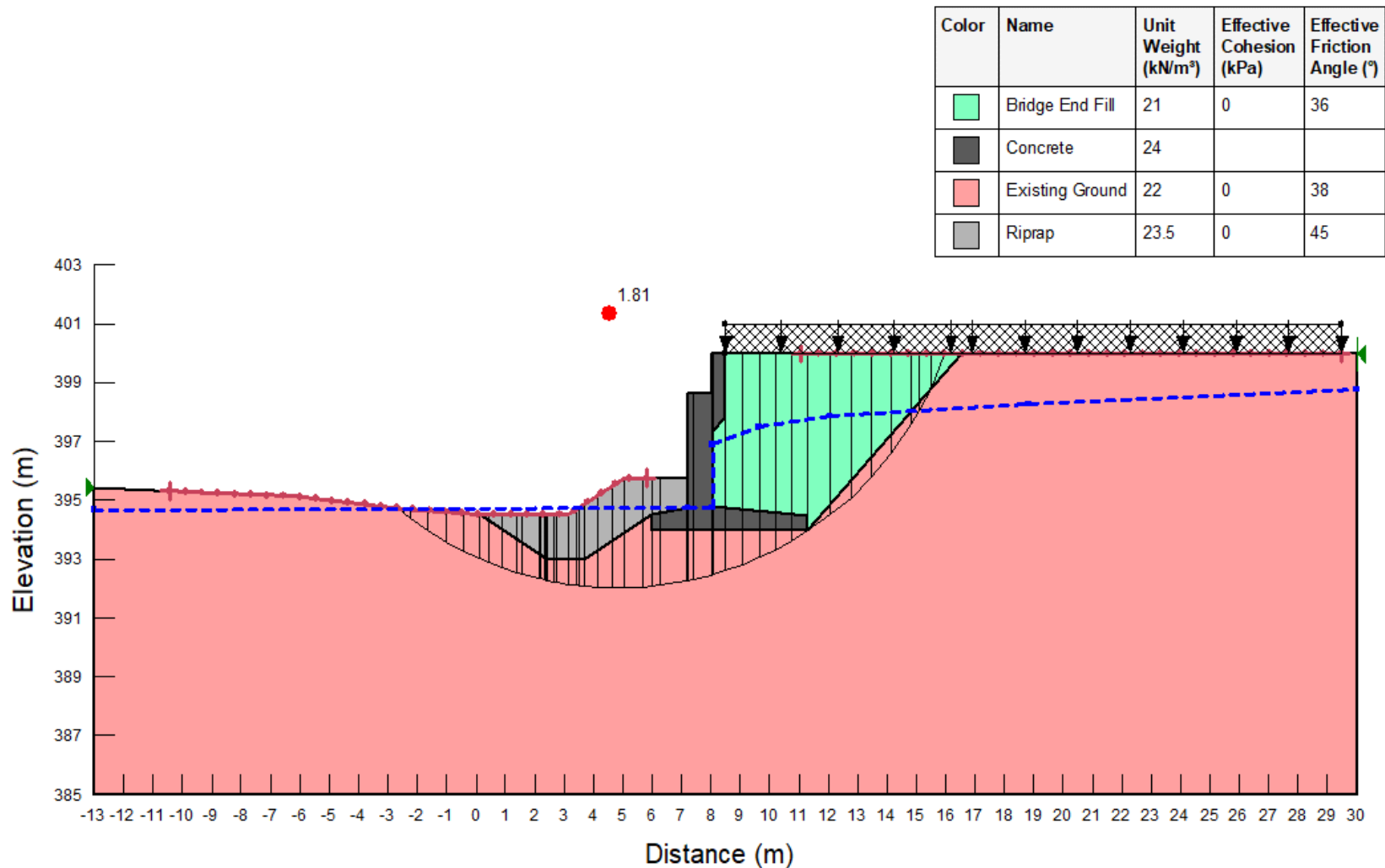

NOTES

1. THIS FIGURE SHOULD BE READ IN CONJUNCTION WITH BGC'S REPORT TITLED "CRAZY CREEK BRIDGE – PRELIMINARY GEOTECHNICAL ASSESSMENT OF SCOUR AND EROSION MITIGATION WORK" AND DATED JUNE 2023.
2. MITIGATION PERMITTING DESIGN BY BGC (CRAZY CREEK BRIDGE NO. 01524) AND DATED FEBRUARY 22, 2023, DRAWINGS PROVIDED IN APPENDIX B OF THIS REPORT.
3. THE SECTION SHOWS THE CONCEPTUAL GEOLOGICAL INTERPRETATION BASED ON THE AVAILABLE INFORMATION AND BOUNDARIES BETWEEN MATERIAL UNITS SHOULD BE CONSIDERED APPROXIMATE.
4. A 20 KPA TRAFFIC SURCHARGE LOAD HAS BEEN APPLIED TO THE HIGHWAY 1 APPROACH.

PREPARED BY: <b>IKP</b>	FIGURE TITLE: <b>CASE 4 – WEST ABUTMENT FOLLOWING RIPRAP PLACEMENT (PERMANENT)</b>		
CHECKED BY: <b>LM</b>	CLIENT: <b>BRITISH COLUMBIA MINISTRY OF TRANSPORTATION AND INFRASTRUCTURE</b>		
APPROVED BY: <b>IKP</b>	SCALE: <b>NTS</b>	PROJECT NO: <b>0272102</b>	FIGURE NO: <b>C-5</b>

0 5 10 mm in ANSI A sized paper



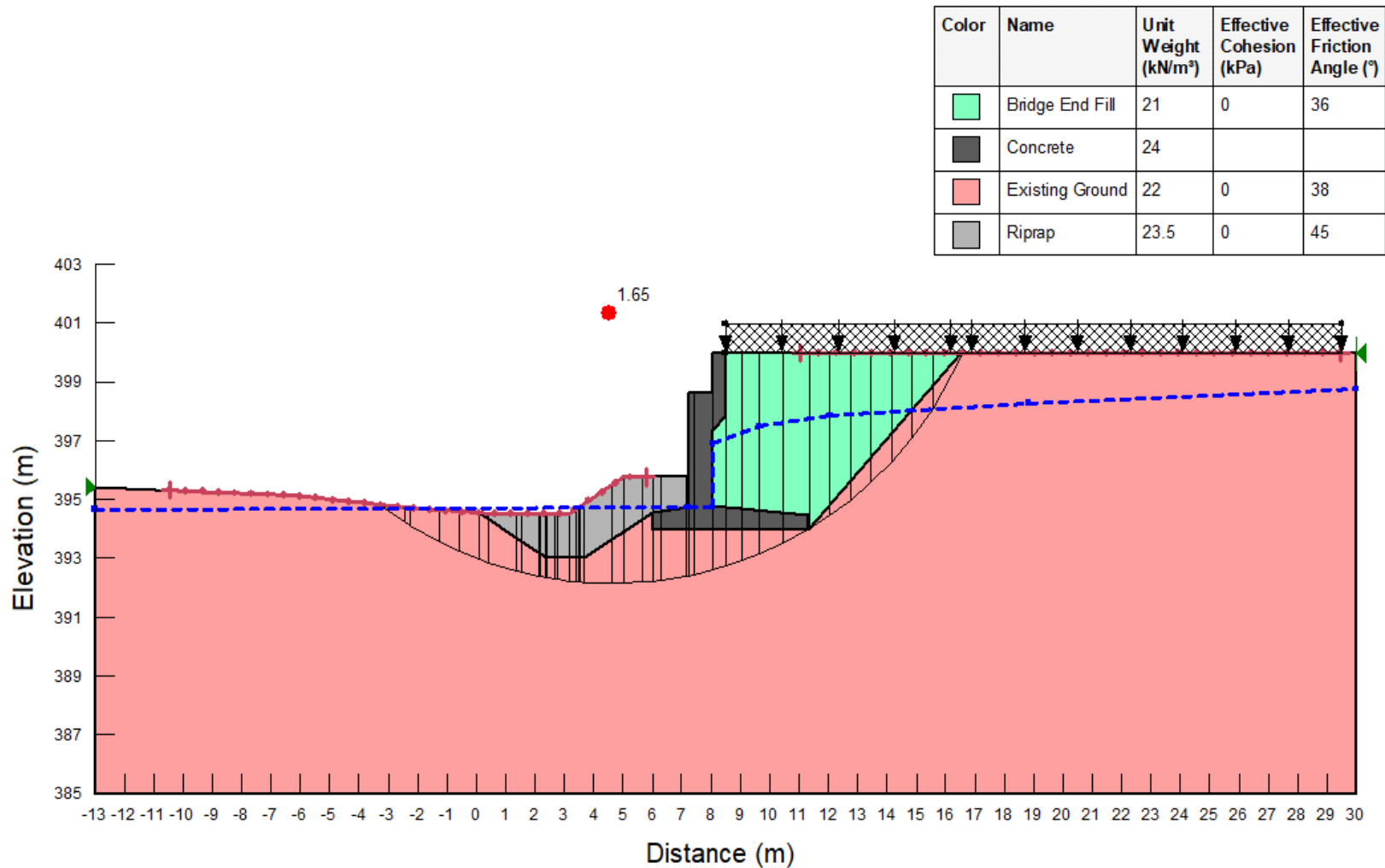

NOTES

1. THIS FIGURE SHOULD BE READ IN CONJUNCTION WITH BGC'S REPORT TITLED "CRAZY CREEK BRIDGE – PRELIMINARY GEOTECHNICAL ASSESSMENT OF SCOUR AND EROSION MITIGATION WORK" AND DATED JUNE 2023.
2. MITIGATION DESIGN BY BGC (CRAZY CREEK BRIDGE NO. 01524) AND DATED FEBRUARY 22, 2023, DRAWINGS PROVIDED IN APPENDIX B OF THIS REPORT.
3. THE SECTION SHOWS THE CONCEPTUAL GEOLOGICAL INTERPRETATION BASED ON THE AVAILABLE INFORMATION AND BOUNDARIES BETWEEN MATERIAL UNITS SHOULD BE CONSIDERED APPROXIMATE.
4. A 20 KPA TRAFFIC SURCHARGE LOAD HAS BEEN APPLIED TO THE HIGHWAY 1 APPROACH.
5. THE PSEUDO STATIC ANALYSIS (PSA) ABOVE IS SHOWN FOR HORIZONTAL PGA (PEAK GROUND ACCELERATION) OF 0.045 G BASED ON A 975-YEAR RETURN PERIOD SITE CLASS C.

PREPARED BY: <b>IKP</b>	FIGURE TITLE: <b>CASE 5 – WEST ABUTMENT FOLLOWING RIPRAP PLACEMENT (SEISMIC)</b>		
CHECKED BY: <b>LM</b>	CLIENT: <b>BRITISH COLUMBIA MINISTRY OF TRANSPORTATION AND INFRASTRUCTURE</b>		
APPROVED BY: <b>IKP</b>	SCALE: <b>NTS</b>	PROJECT NO: <b>0272102</b>	FIGURE NO: <b>C-6</b>

0 5 10 mm in ANSI A sized paper

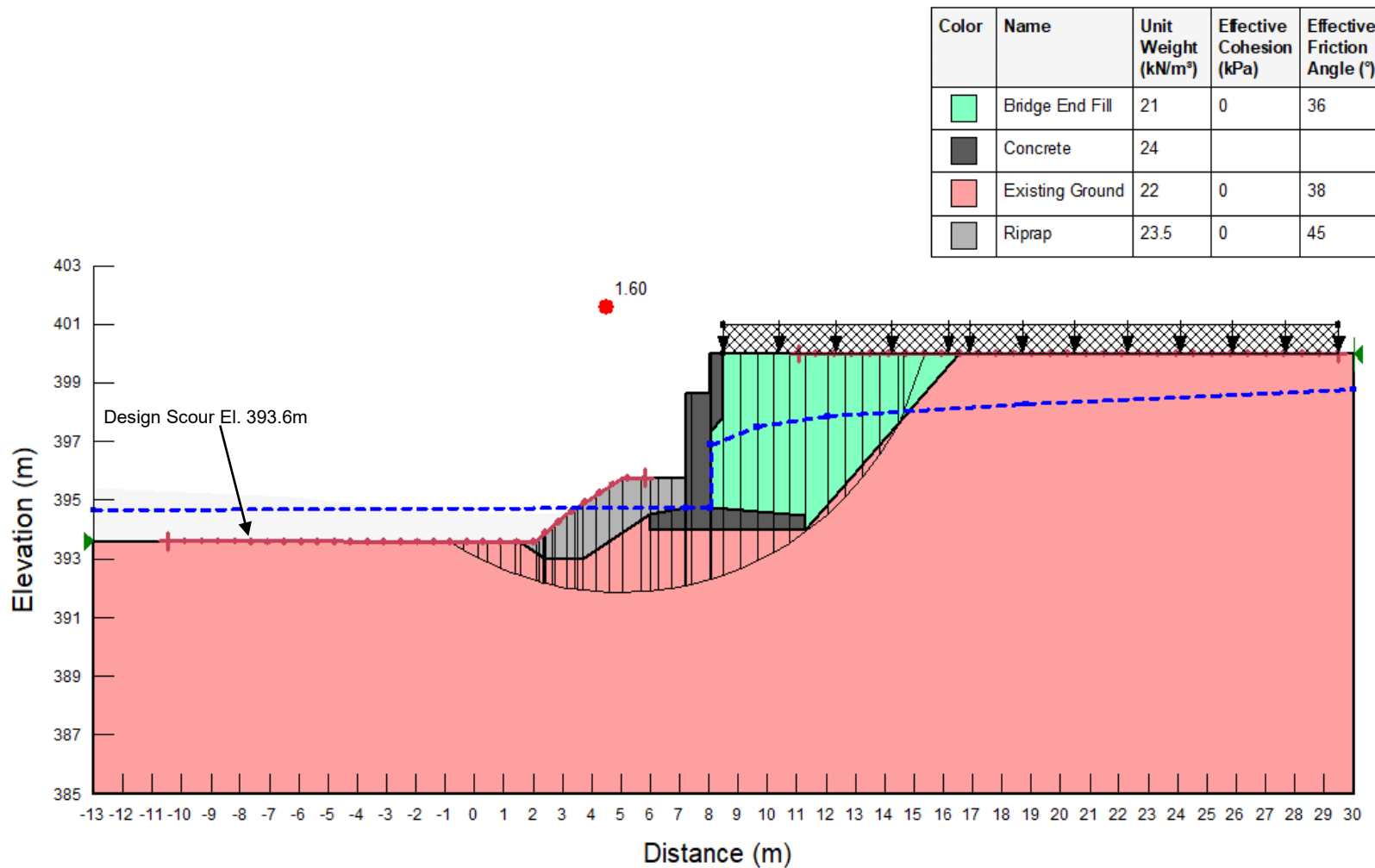

NOTES

1. THIS FIGURE SHOULD BE READ IN CONJUNCTION WITH BGC'S REPORT TITLED "CRAZY CREEK BRIDGE – PRELIMINARY GEOTECHNICAL ASSESSMENT OF SCOUR AND EROSION MITIGATION WORK" AND DATED JUNE 2023.
2. MITIGATION PERMITTING DESIGN BY BGC (CRAZY CREEK BRIDGE NO. 01524) AND DATED FEBRUARY 22, 2023, DRAWINGS PROVIDED IN APPENDIX B OF THIS REPORT.
3. THE SECTION SHOWS THE CONCEPTUAL GEOLOGICAL INTERPRETATION BASED ON THE AVAILABLE INFORMATION AND BOUNDARIES BETWEEN MATERIAL UNITS SHOULD BE CONSIDERED APPROXIMATE.
4. A 20 KPA TRAFFIC SURCHARGE LOAD HAS BEEN APPLIED TO THE HIGHWAY 1 APPROACH.

PREPARED BY: <b>IKP</b>	FIGURE TITLE: <b>CASE 6 – WEST ABUTMENT FOLLOWING RIPRAP PLACEMENT WITH SCOUR (PERMANENT)</b>		
CHECKED BY: <b>LM</b>	CLIENT: <b>BRITISH COLUMBIA MINISTRY OF TRANSPORTATION AND INFRASTRUCTURE</b>		
APPROVED BY: <b>IKP</b>	SCALE: <b>NTS</b>	PROJECT NO: <b>0272102</b>	FIGURE NO: <b>C-7</b>

0 5 10 mm in ANSI A sized paper



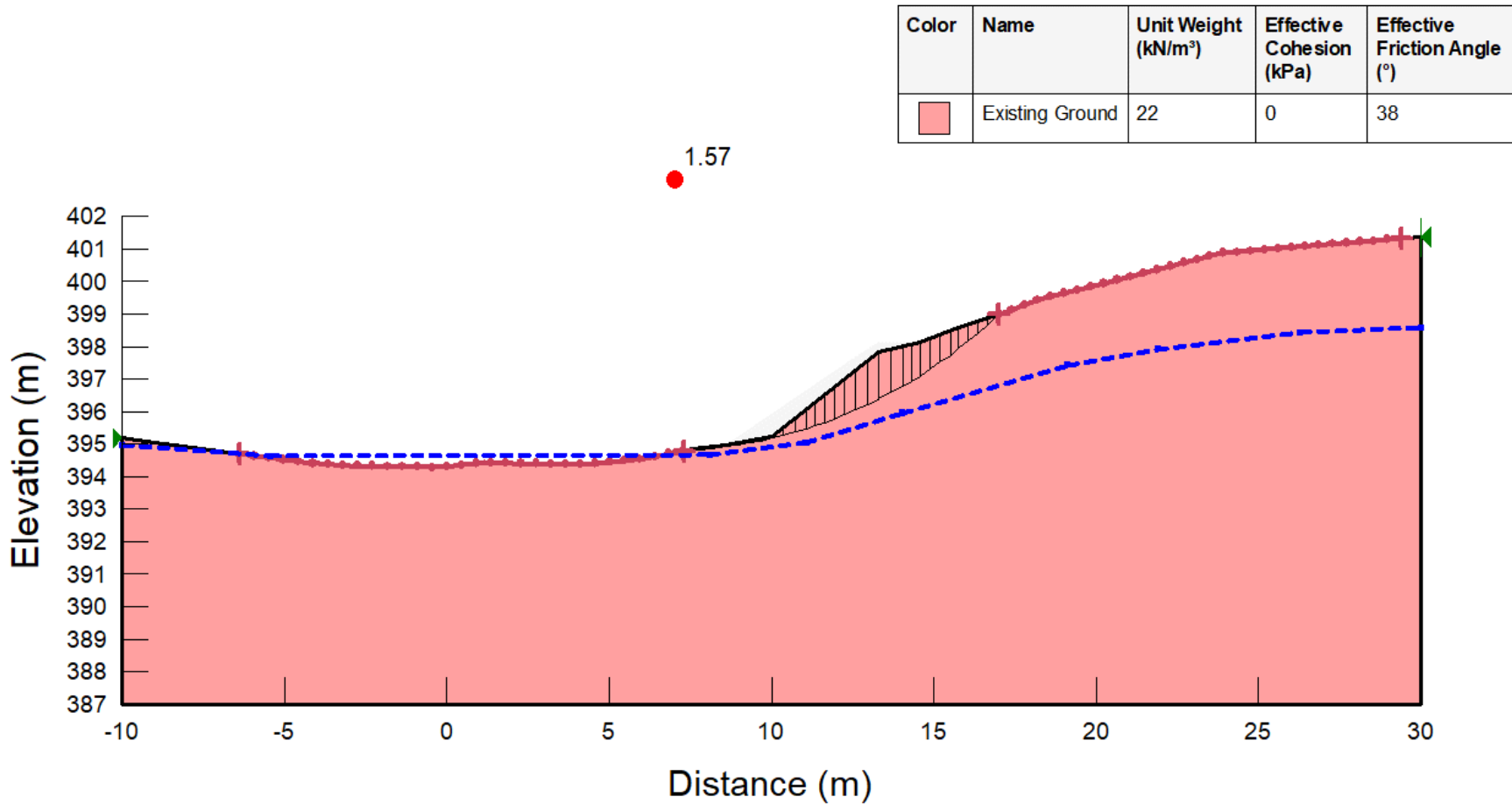

NOTES

1. THIS FIGURE SHOULD BE READ IN CONJUNCTION WITH BGC'S REPORT TITLED "CRAZY CREEK BRIDGE – PRELIMINARY GEOTECHNICAL ASSESSMENT OF SCOUR AND EROSION MITIGATION WORK" AND DATED JUNE 2023.
2. MITIGATION PERMITTING DESIGN BY BGC (CRAZY CREEK BRIDGE NO. 01524) AND DATED FEBRUARY 22, 2023, DRAWINGS PROVIDED IN APPENDIX B OF THIS REPORT.
3. THE SECTION SHOWS THE CONCEPTUAL GEOLOGICAL INTERPRETATION BASED ON THE AVAILABLE INFORMATION AND BOUNDARIES BETWEEN MATERIAL UNITS SHOULD BE CONSIDERED APPROXIMATE.

PREPARED BY: <b>IKP</b>	FIGURE TITLE: <b>CASE 1 – WEST EMBANKMENT EXISTING CONDITIONS</b>		
CHECKED BY: <b>LM</b>	CLIENT: <b>BRITISH COLUMBIA MINISTRY OF TRANSPORTATION AND INFRASTRUCTURE</b>		
APPROVED BY: <b>IKP</b>	SCALE: <b>NTS</b>	PROJECT NO: <b>0272102</b>	FIGURE NO: <b>C-8</b>

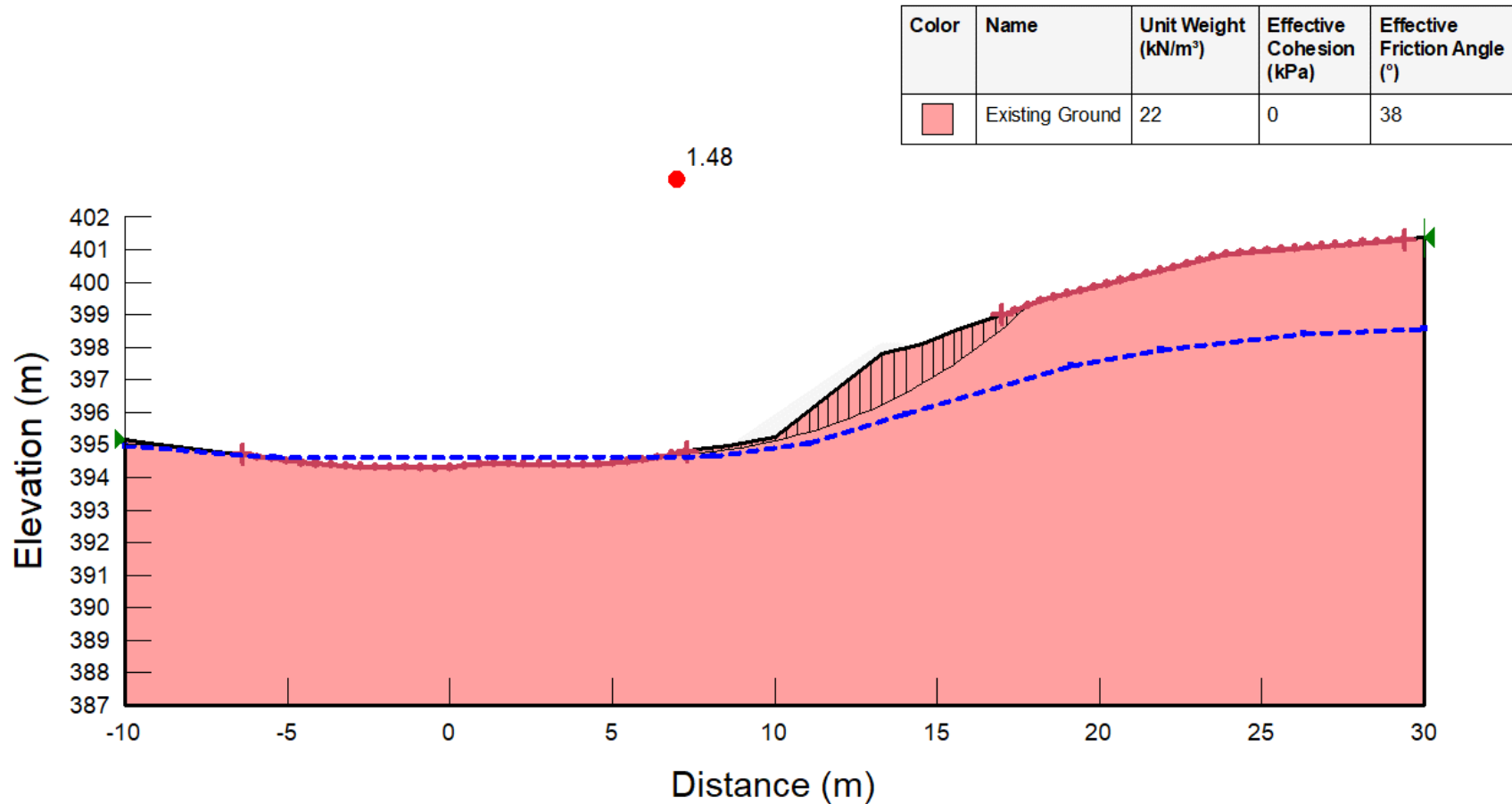

NOTES

1. THIS FIGURE SHOULD BE READ IN CONJUNCTION WITH BGC'S REPORT TITLED "CRAZY CREEK BRIDGE – PRELIMINARY GEOTECHNICAL ASSESSMENT OF SCOUR AND EROSION MITIGATION WORK" AND DATED JUNE 2023.
2. MITIGATION PERMITTING DESIGN BY BGC (CRAZY CREEK BRIDGE NO. 01524) AND DATED FEBRUARY 22, 2023, DRAWINGS PROVIDED IN APPENDIX B OF THIS REPORT.
3. THE SECTION SHOWS THE CONCEPTUAL GEOLOGICAL INTERPRETATION BASED ON THE AVAILABLE INFORMATION AND BOUNDARIES BETWEEN MATERIAL UNITS SHOULD BE CONSIDERED APPROXIMATE.
4. THE PSEUDO STATIC ANALYSIS (PSA) ABOVE IS SHOWN FOR HORIZONTAL PGA (PEAK GROUND ACCELERATION) OF 0.045 G BASED ON A 975-YEAR RETURN PERIOD SITE CLASS C.

PREPARED BY: <b>IKP</b>	FIGURE TITLE: <b>CASE 2 – WEST EMBANKMENT EXISTING CONDITIONS (SEISMIC)</b>		
CHECKED BY: <b>LM</b>	CLIENT: <b>BRITISH COLUMBIA MINISTRY OF TRANSPORTATION AND INFRASTRUCTURE</b>		
APPROVED BY: <b>IKP</b>	SCALE: <b>NTS</b>	PROJECT NO: <b>0272102</b>	FIGURE NO: <b>C-9</b>

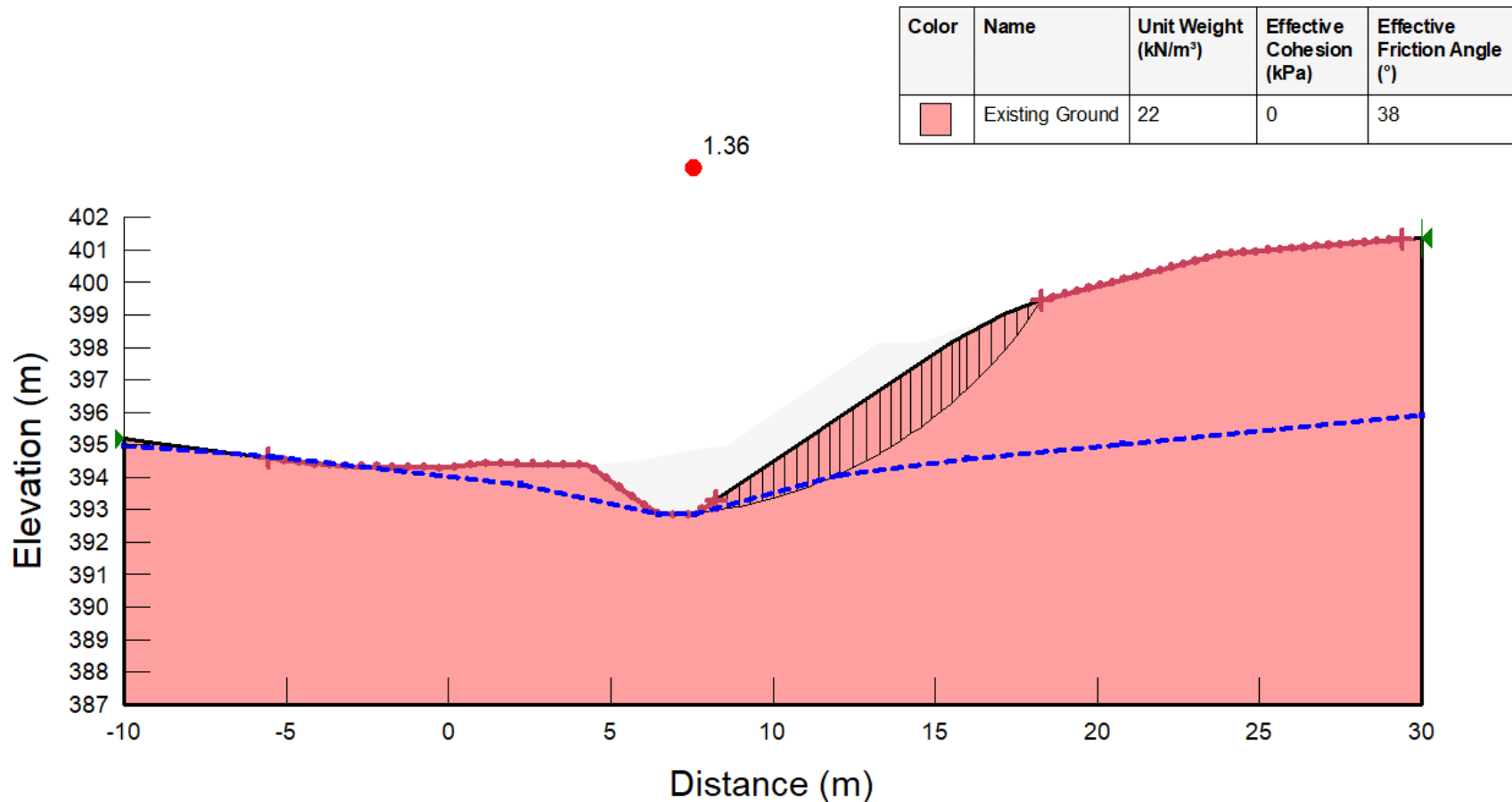

NOTES

1. THIS FIGURE SHOULD BE READ IN CONJUNCTION WITH BGC'S REPORT TITLED "CRAZY CREEK BRIDGE – PRELIMINARY GEOTECHNICAL ASSESSMENT OF SCOUR AND EROSION MITIGATION WORK" AND DATED JUNE 2023.
2. MITIGATION PERMITTING DESIGN BY BGC (CRAZY CREEK BRIDGE NO. 01524) AND DATED FEBRUARY 22, 2023, DRAWINGS PROVIDED IN APPENDIX B OF THIS REPORT.
3. THE SECTION SHOWS THE CONCEPTUAL GEOLOGICAL INTERPRETATION BASED ON THE AVAILABLE INFORMATION AND BOUNDARIES BETWEEN MATERIAL UNITS SHOULD BE CONSIDERED APPROXIMATE.
4. A SLIGHTLY LOW PIEZOMETRIC SURFACE THAN EXISTING CONDITIONS (CASE 1) HAS BEEN USED. THE MINIMUM SLIP SURFACE WAS RESTRICTED TO BE GREATER THAN 2 M TO FILTER SHALLOW NEAR SURFACE POTENTIAL SLIPS FROM THE RESULTS.

PREPARED BY: <b>IKP</b>	FIGURE TITLE: <b>CASE 3 – WEST EMBANKMENT RIPRAP EXCAVATION (TEMPORARY)</b>		
CHECKED BY: <b>LM</b>	CLIENT: <b>BRITISH COLUMBIA MINISTRY OF TRANSPORTATION AND INFRASTRUCTURE</b>		
APPROVED BY: <b>IKP</b>	SCALE: <b>NTS</b>	PROJECT NO: <b>0272102</b>	FIGURE NO: <b>C-10</b>

0 5 10 mm in ANSI A sized paper

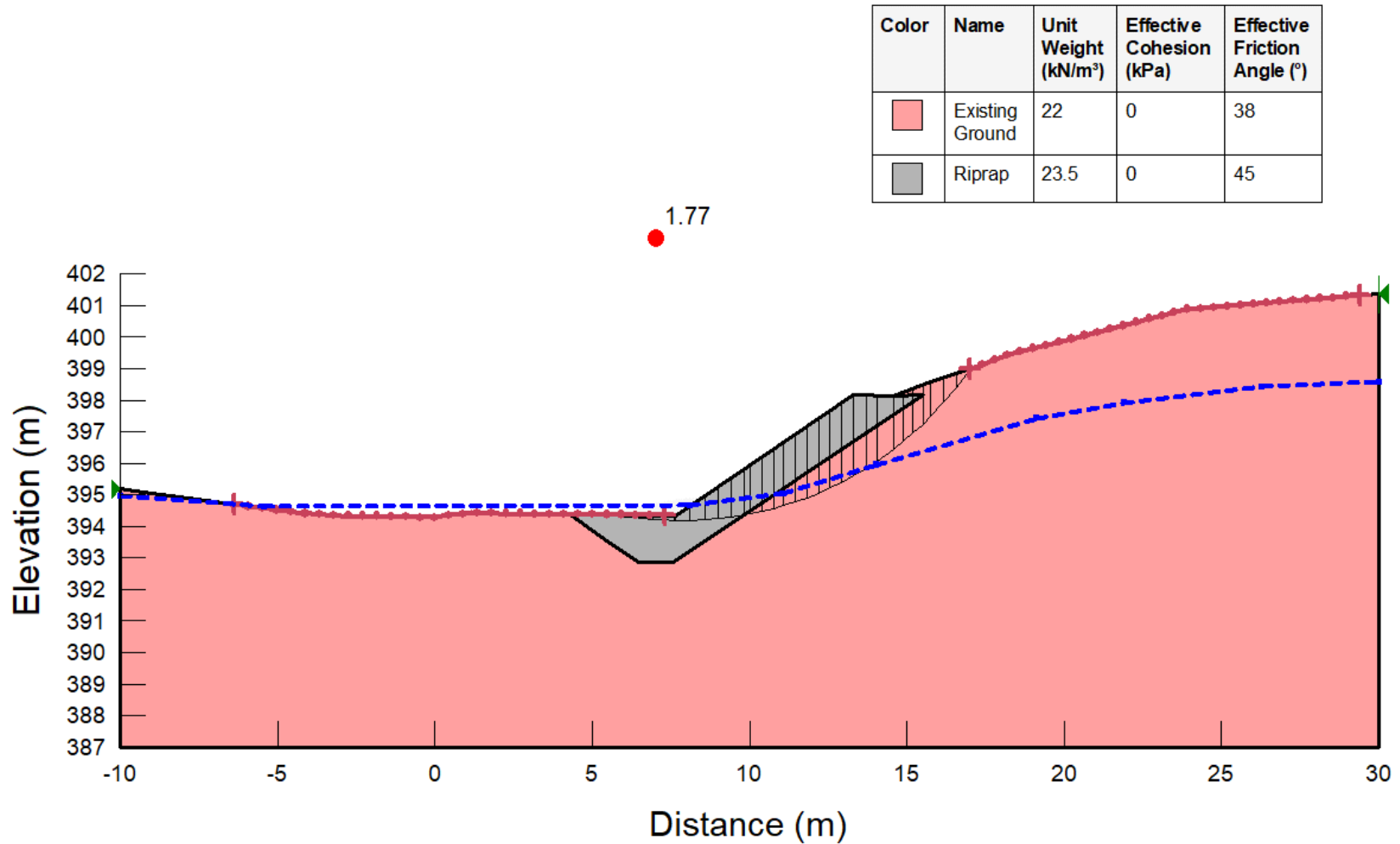

NOTES

1. THIS FIGURE SHOULD BE READ IN CONJUNCTION WITH BGC'S REPORT TITLED "CRAZY CREEK BRIDGE – PRELIMINARY GEOTECHNICAL ASSESSMENT OF SCOUR AND EROSION MITIGATION WORK" AND DATED JUNE 2023.
2. MITIGATION PERMITTING DESIGN BY BGC (CRAZY CREEK BRIDGE NO. 01524) AND DATED FEBRUARY 22, 2023, DRAWINGS PROVIDED IN APPENDIX B OF THIS REPORT.
3. THE SECTION SHOWS THE CONCEPTUAL GEOLOGICAL INTERPRETATION BASED ON THE AVAILABLE INFORMATION AND BOUNDARIES BETWEEN MATERIAL UNITS SHOULD BE CONSIDERED APPROXIMATE.

PREPARED BY: <b>IKP</b>	FIGURE TITLE: <b>CASE 4 – WEST EMBANKMENT FOLLOWING RIPRAP PLACEMENT (PERMANENT)</b>		
CHECKED BY: <b>LM</b>	CLIENT: <b>BRITISH COLUMBIA MINISTRY OF TRANSPORTATION AND INFRASTRUCTURE</b>		
APPROVED BY: <b>IKP</b>	SCALE: <b>NTS</b>	PROJECT NO: <b>0272102</b>	FIGURE NO: <b>C-11</b>

0 5 10 mm in ANSI A sized paper

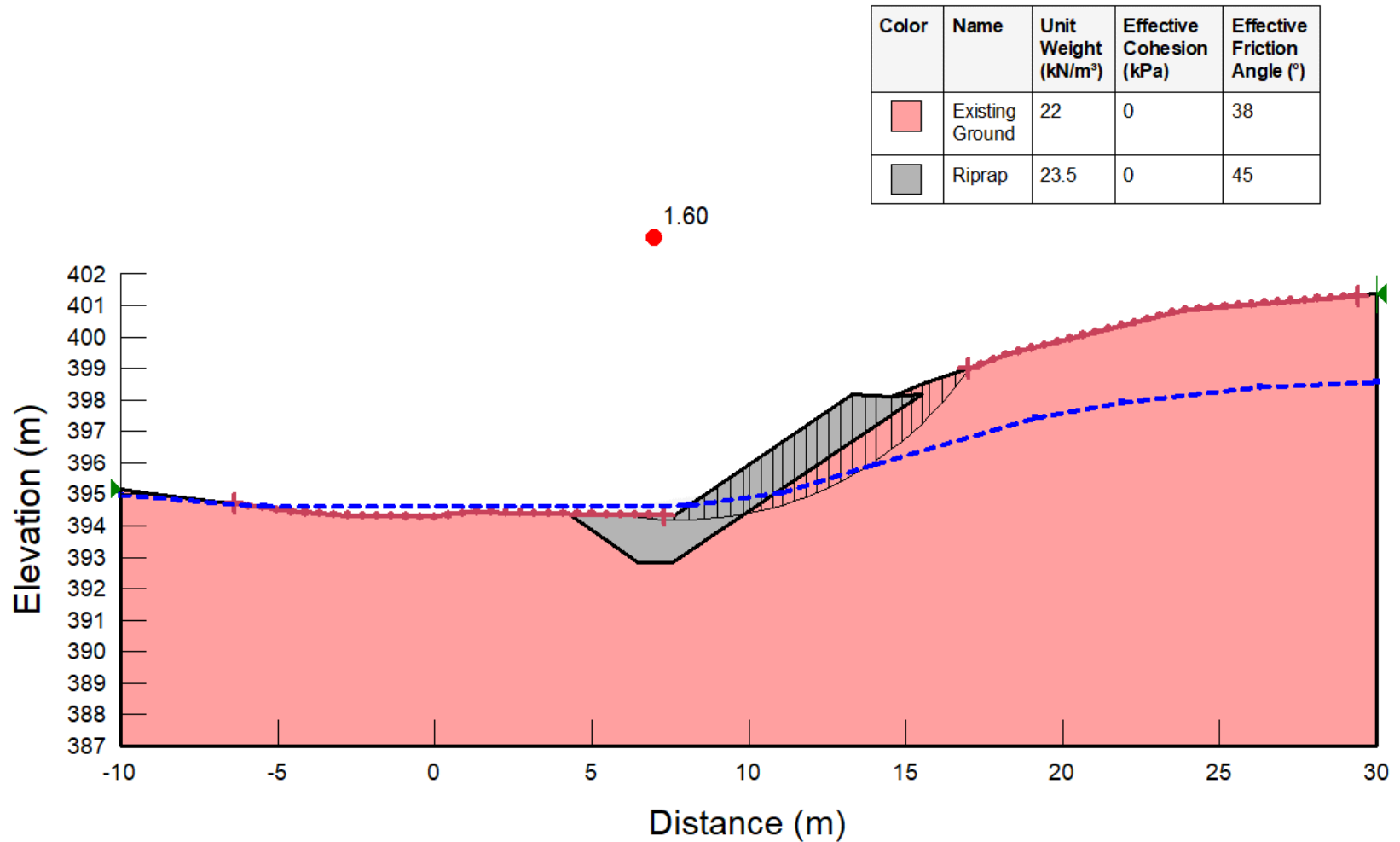

NOTES

1. THIS FIGURE SHOULD BE READ IN CONJUNCTION WITH BGC'S REPORT TITLED "CRAZY CREEK BRIDGE – PRELIMINARY GEOTECHNICAL ASSESSMENT OF SCOUR AND EROSION MITIGATION WORK" AND DATED JUNE 2023.
2. MITIGATION PERMITTING DESIGN BY BGC (CRAZY CREEK BRIDGE NO. 01524) AND DATED FEBRUARY 22, 2023, DRAWINGS PROVIDED IN APPENDIX B OF THIS REPORT.
3. THE SECTION SHOWS THE CONCEPTUAL GEOLOGICAL INTERPRETATION BASED ON THE AVAILABLE INFORMATION AND BOUNDARIES BETWEEN MATERIAL UNITS SHOULD BE CONSIDERED APPROXIMATE.
4. THE PSEUDO STATIC ANALYSIS (PSA) ABOVE IS SHOWN FOR HORIZONTAL PGA (PEAK GROUND ACCELERATION) OF 0.045 G BASED ON A 975-YEAR RETURN PERIOD SITE CLASS C.

PREPARED BY: <b>IKP</b>	FIGURE TITLE: <b>CASE 5 – WEST EMBANKMENT FOLLOWING RIPRAP PLACEMENT (SEISMIC)</b>		
CHECKED BY: <b>LM</b>	CLIENT: <b>BRITISH COLUMBIA MINISTRY OF TRANSPORTATION AND INFRASTRUCTURE</b>		
APPROVED BY: <b>IKP</b>	SCALE: <b>NTS</b>	PROJECT NO: <b>0272102</b>	FIGURE NO: <b>C-12</b>

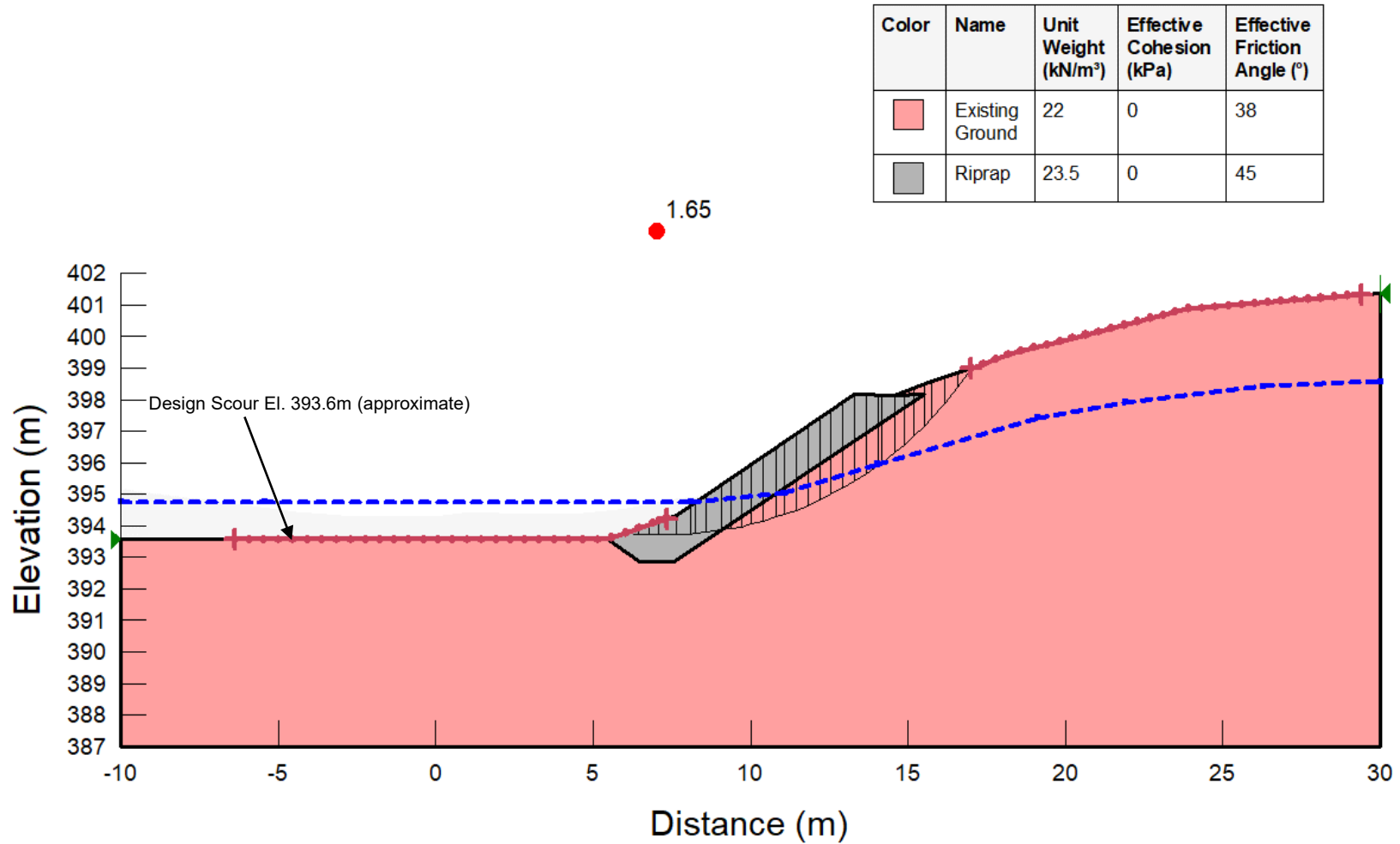

NOTES

1. THIS FIGURE SHOULD BE READ IN CONJUNCTION WITH BGC'S REPORT TITLED "CRAZY CREEK BRIDGE – PRELIMINARY GEOTECHNICAL ASSESSMENT OF SCOUR AND EROSION MITIGATION WORK" AND DATED JUNE 2023.
2. MITIGATION PERMITTING DESIGN BY BGC (CRAZY CREEK BRIDGE NO. 01524) AND DATED FEBRUARY 22, 2023, DRAWINGS PROVIDED IN APPENDIX B OF THIS REPORT.
3. THE SECTION SHOWS THE CONCEPTUAL GEOLOGICAL INTERPRETATION BASED ON THE AVAILABLE INFORMATION AND BOUNDARIES BETWEEN MATERIAL UNITS SHOULD BE CONSIDERED APPROXIMATE.

PREPARED BY: <b>IKP</b>	FIGURE TITLE: <b>CASE 6 – WEST EMBANKMENT FOLLOWING RIPRAP PLACEMENT WITH SCOUR (PERMANENT)</b>		
CHECKED BY: <b>LM</b>	CLIENT: <b>BRITISH COLUMBIA MINISTRY OF TRANSPORTATION AND INFRASTRUCTURE</b>		
APPROVED BY: <b>IKP</b>	SCALE: <b>NTS</b>	PROJECT NO: <b>0272102</b>	FIGURE NO: <b>C-13</b>

## **APPENDIX D SELECT SITE PHOTOGRAPHS**





**Photograph 1.** View looking northeast (upstream) at the Crazy Creek Bridge (Photograph by BGC taken on April 26, 2023).



**Photograph 2.** View looking east at the upstream wingwall of the east abutment (Photograph by BGC taken on April 26, 2023).





**Photograph 3.** View looking south (downstream) along the east abutment foundation wall. The measuring tape is extended to 1 m in the photo (Photograph by BGC taken on April 26, 2023).



**Photograph 4.** View looking east (upstream) at the downstream wing wall of the east abutment. (Photograph by BGC taken on April 26, 2023).





Photograph 5. View looking west at the downstream wing wall of the west abutment (Photograph by BGC taken on April 26, 2023).



Photograph 6. View looking north (upstream) at the downstream wing wall of the west abutment (Photograph by BGC taken on April 26, 2023).





**Photograph 7.** View looking south (downstream) at the west abutment foundation wall (Photograph by BGC taken on April 26, 2023).



**Photograph 8.** View looking north (upstream) at the upstream wing wall of the west abutment (Photograph by BGC taken on April 26, 2023).





Photograph 9. View looking northwest at the upstream wing wall of the west abutment (Photograph by BGC taken on April 26, 2023).

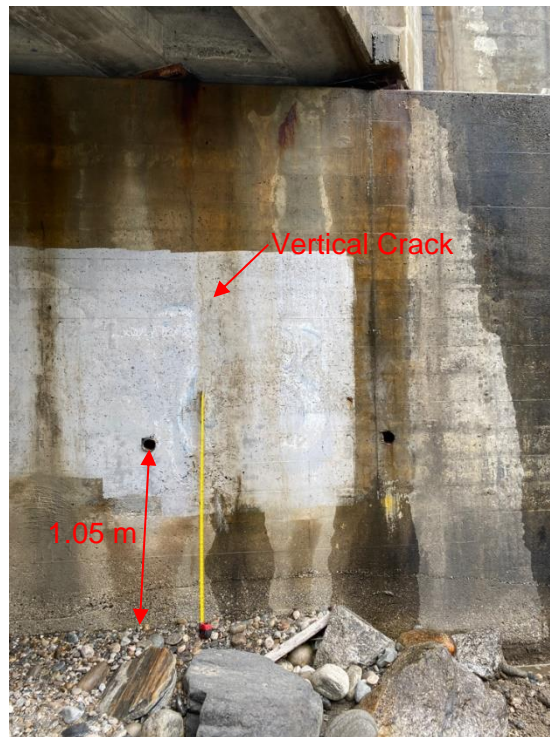

Photograph 10. View looking southeast at east abutment foundation wall. A vertical crack was observed extending from the top of wall to within 0.5 m of the gravel channel bed. A crack aperture of 1 mm was measured. The distance between the foundation wall drain hole to the current channel bed was measured to be 1.05 m (Photograph by BGC taken on April 26, 2023).



**Photograph 11.** View looking northwest damaged/disconnected wiring on the gabion basket (Photograph by BGC taken on April 26, 2023).