

PLOT DATE: 2024-08-22 5:18:49 PM yke U:\Projects_SUR\1961\0518\05\Design\CAD\DrawingProduction\1000_DesignSections\1000_X SECTIONS_H7_SHERLING.dwg

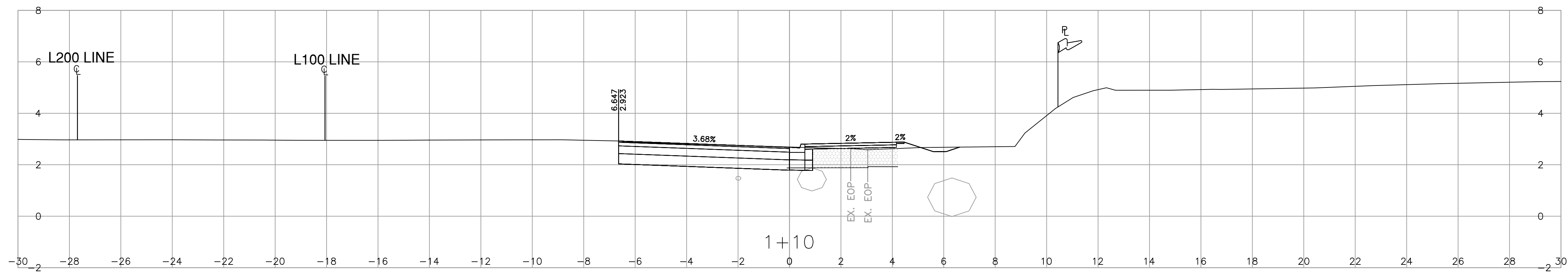

REV	DATE	REVISIONS	NAME
1	2024-08-23	TENDER ADDENDUM #2	I. MACMILLAN

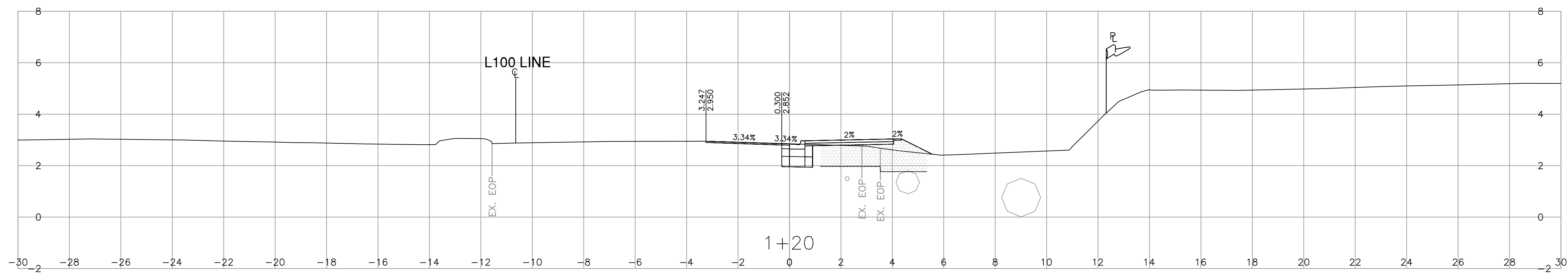
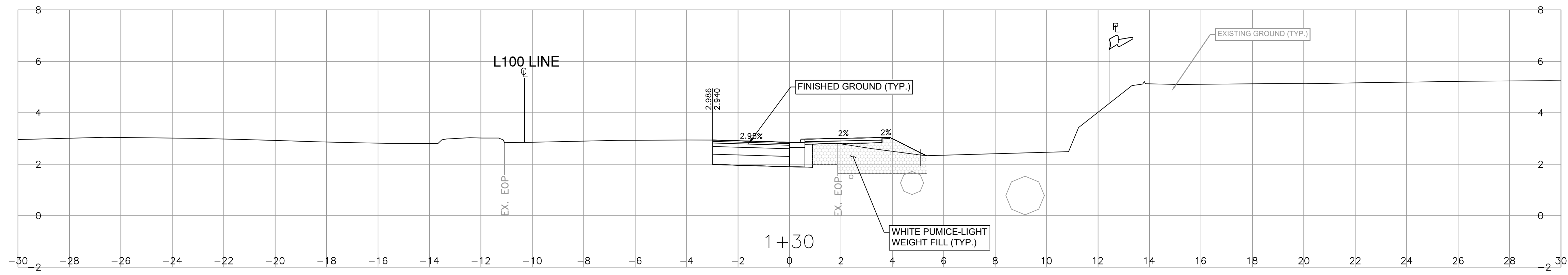
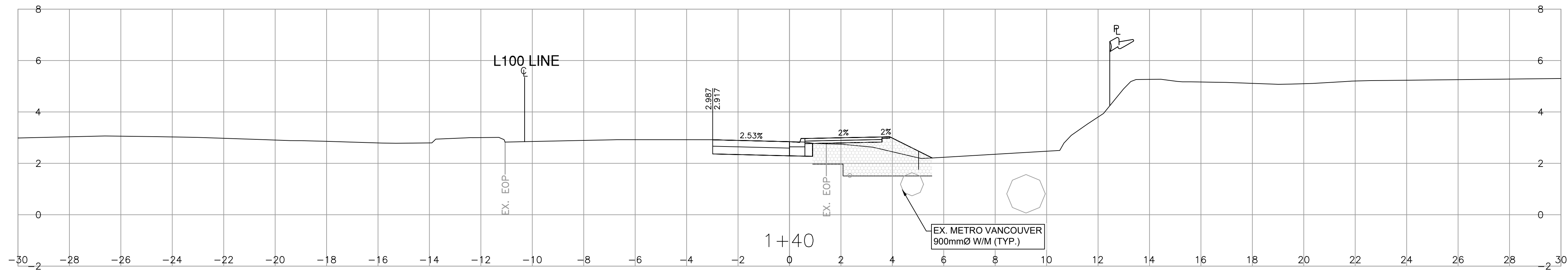

MINISTRY OF TRANSPORTATION
AND INFRASTRUCTURE
SOUTH COAST REGION
HIGHWAY ENGINEERING AND GEOMATICS



CAD FILENAME	1000_X SECTIONS_H7_SHERLING	DESIGNED	R. MOOTOOSAMY	DATE	2023-11-17
FILE NUMBER	1961.0518.05	QUALITY CONTROL	I. MACMILLAN	DATE	2023-11-17
PLOT DATE	2024-08-22	QUALITY ASSURANCE	J. BORCH	DATE	2023-11-17
		DRAWN	Y. KE	DATE	2023-11-17

DESIGN SECTIONS

HIGHWAY 7 BUS STOP
EB SHERLING AVE
STA 1+20.000 TO STA 1+50.000

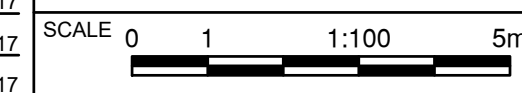

PROJECT NUMBER	13234-0001	REG	1	DRAWING NUMBER	R1-1123-1001	REV	1
----------------	------------	-----	---	----------------	--------------	-----	---

PLOT DATE: 2024-08-22 5:18:51 PM yke U:\Projects_SUR\1961\0518\05\Design\CAD\DrawingProduction\1000_X SECTIONS\H7_SHERLING.dwg

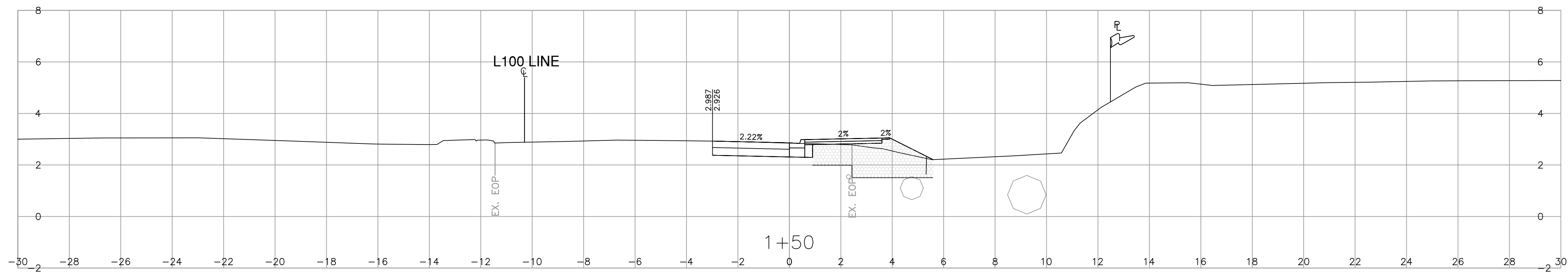
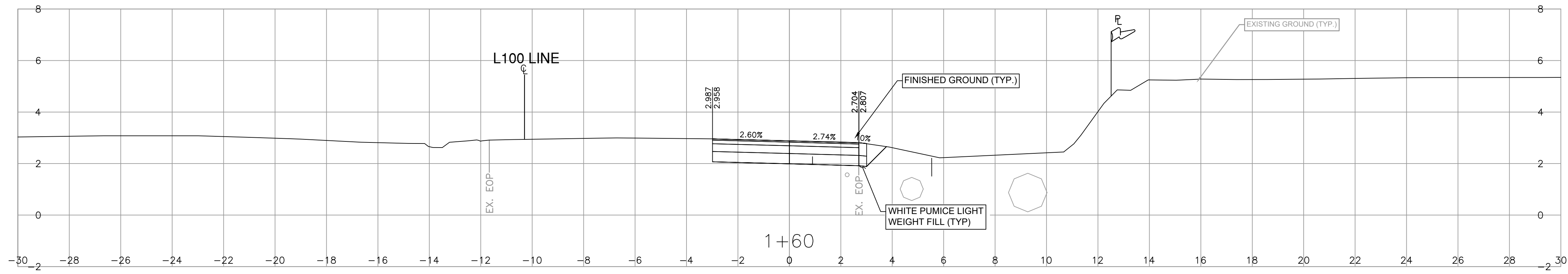
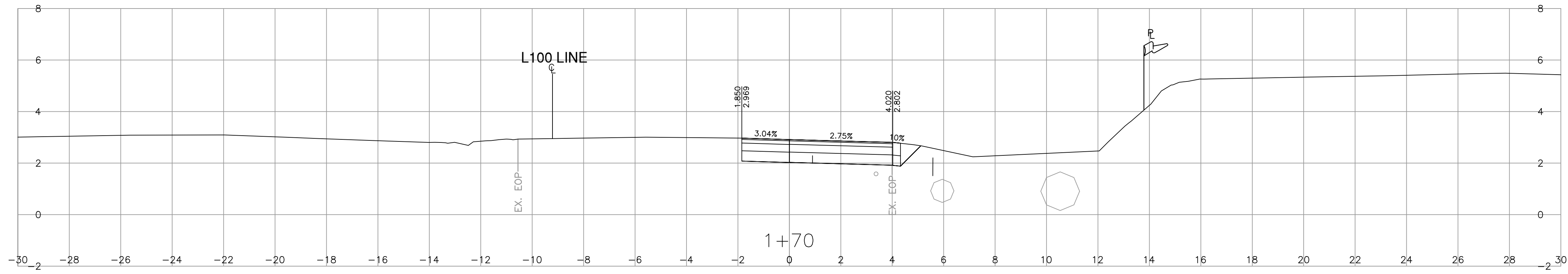
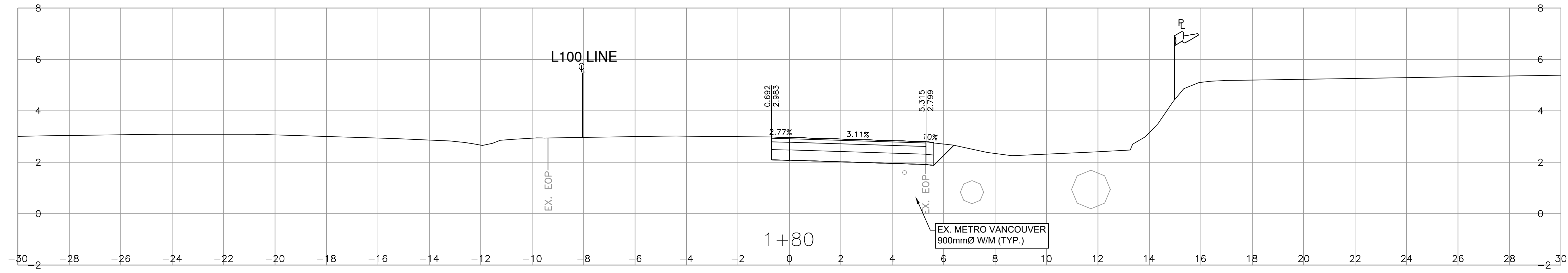

REV	DATE	REVISIONS	NAME
1	2024-08-23	TENDER ADDENDUM #2	I. MACMILLAN



MINISTRY OF TRANSPORTATION AND INFRASTRUCTURE
SOUTH COAST REGION
HIGHWAY ENGINEERING AND GEOMATICS



DESIGNED: R. MOOTOOSAMY DATE: 2023-11-17
 QUALITY CONTROL: I. MACMILLAN DATE: 2023-11-17
 FILE NUMBER: 1961.0518.05 QUALITY ASSURANCE: J. BORCH DATE: 2023-11-17
 PLOT DATE: 2024-08-22 DRAWN: Y. KE DATE: 2023-11-17

DESIGN SECTIONS

HIGHWAY 7 BUS STOP
EB SHERLING AVE
STA 1+60.000 TO STA 1+90.000

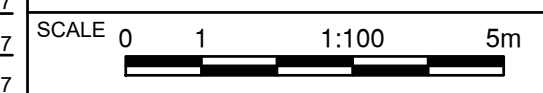

PROJECT NUMBER: 13234-0001 REG: 1 DRAWING NUMBER: R1-1123-1002 REV: 1