

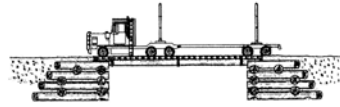

Ministry of
Forests, Lands and
Natural Resource Operations

**Engineering Branch, Timber
Pricing and Operations Division**

ENGINEERING BULLETIN



Number #3 May 15, 2012

Considerations for Transmission Line Crossings of Forest Service Roads (FSRs)

This bulletin is best viewed electronically as there are embedded hyperlinks to reference documents. The guidance in this bulletin applies to FSRs, and addresses electric power transmission line infrastructure that is proposed within or adjacent to the FSR right-of-way. It provides guidance for:

1. transmission line planning and road crossing considerations;
2. horizontal clearances from proposed roadside transmission structures or poles;
3. vertical clearances of proposed overhead transmission line crossings of roads.

This guidance is directed toward District and BCTS staff in the Engineering Program, including Engineering Branch staff, responsible for management of the FSR network. It may be helpful to other internal or external stakeholders, planners and consultants. The guidance may also be helpful to stakeholders responsible for other resource roads that may be affected by transmission line crossings.

A. General transmission line planning and design considerations

1. **Confirmation of land use / normal transportation requirements for transmission line planning and design:** At the transmission line planning and design phases, it is necessary to confirm the land use and normal transportation requirements related to forest operations in an area. Guidance on these aspects is available from the ministry district office and/or through discussion with affected forest companies in the area. It is important for utility owners, the ministry and affected stakeholders to partner, communicate, coordinate and cooperate during these phases.
2. **Alignment of overhead line crossings:** If practicable, the design of overhead line crossings of existing or planned roads should be as near right angle as possible to minimize the distance of the crossing. Multiple line crossings should be avoided and may be unacceptable on some roads.
3. **Timber harvesting operations:** As applicable, there must be provision in the transmission line route and design to prevent potential negative effects on timber harvesting operations and forest management objectives in the area (e.g., to prevent loss of operable forestland). Be mindful of the following:
 - a. The potential for isolation of timber harvesting opportunities (e.g., by cable operations) can be an important consideration. For example, transmission lines that are installed parallel to the road right-of-way can prevent or make it more difficult to cable harvest timber on one or both sides of the road.
 - b. Helicopter-logging operations may be adversely affected because of restrictions placed on flying over transmission lines and safety hazards. The spacing and width of helicopter yarding corridors would have to be discussed with the district manager and affected forest agreement holders.

4. **Notification requirements for proposed new roads crossing under existing transmission lines:** For existing transmission lines, and to provide assurance that legislative requirements have been met and design expectations for safety have been considered, no new roads should be constructed to cross the transmission line rights-of-way without the design guidance and approval of the owner of the power system. The process that deals with any application for a road crossing of an existing transmission line must also focus on options to minimize the impact on forest operations and future road access in the area of interest.
5. **Standards:** Design and construction for transmission line towers, poles, overhead cable and supporting structures (e.g., guy lines) must meet or exceed standards established by the Canadian Standards Association and WorkSafeBC, and / or other regulatory agencies which have authority. Where the ministry has prescribed a more stringent standard than other regulators, the ministry's standard will apply. Similarly where a regulatory authority requires a higher standard than those prescribed by the ministry, the regulator's standard will apply. See Section C for specific CSA and WorkSafeBC standards information.

B. Horizontal clearances from proposed roadside transmission tower or power poles

Where a project transmission line and its right-of-way pass over forested lands, overhead transmission line crossings may be required over existing FSRs. It is important to design for sufficient horizontal clearance from roadside transmission line towers or poles to accommodate industrial traffic through road curvatures and allow safe trailer tracking for over length log haul trailer loads or equipment. Careful design to properly locate above-ground obstacles such as transmission line towers, poles, guy lines and other supporting structures along a road right-of-way is required to avoid unduly restricting industrial traffic, creating new roadside safety hazards, or interfering with roadside maintenance operations.

1. **Consider vehicle tracking requirements and road user safety:** In locating towers, poles, guy lines and other structures along an FSR right-of-way, provide for the greatest possible horizontal setback distance from the edge of the road running surface.
 - a. Optimally, all transmission line towers, poles, guy lines and other associated structures will be located 3 m horizontal distance away from both the top of road cuts and toe of road fills to maintain the integrity of the road prism. Variations on this optimum horizontal setback distance may be authorized by the ministry on a site specific basis. If the ministry authorizes a lesser horizontal setback distance, the following minimum requirements must be met among other ministry requirements if specified:
 - In all circumstances, these structures will be located outside road ditch lines and well clear of all running surfaces of roads to allow off-highway movement of industrial traffic, with a minimum of 3 m horizontal distance away from the edge of the road running surface. For off-highway log haul roads, this distance will be increased to facilitate the turning radius of over length log haul trailer loads (e.g., combined vehicle and load lengths can range between about 27 to 30 metres).
2. **Avoid interfering with future road maintenance and modifications:** The placement of the transmission line towers, poles, guy lines and other associated structures should be designed considering the requirements for long term road maintenance activities and possible future modifications within the road prism and clearing width of the road. With these considerations in mind, determine the best side of the roadway for a pole line. Minimize the number of poles down the right-of-way (space the poles as far apart as possible). Also, for road user safety, locate poles to minimize the potential to interfere with a driver's line of sight.

C. Vertical clearances of proposed overhead transmission line crossings

Some important factors to consider in the design of vertical clearances include, among others:

1. **Identify road crossing locations:** All existing, planned, or reasonably predicted road crossing locations should be considered in the transmission line design.
2. **Identify configuration of forest equipment:** Without sufficient vertical clearance above the road, overhead transmission lines have the potential to restrict industrial operations of authorized road users. Transmission line clearance to the road is not expected to accommodate every possible configuration of forest equipment in use. However, sufficient clearance should permit safe passage of equipment (in a normal transport configuration) that can reasonably be expected to regularly use the FSR (and connecting roads in an area if applicable), now or in the future. Obtain relevant manufacturers' equipment height diagrams. An example grapple yarder equipment height diagram is provided in Appendix 1.
 - a. Vehicles or equipment may either move unaided along a road, or else be transported on a low bed. During planning and design of transmission lines in a given area of forest operations, it is important to determine the governing vehicle load heights or equipment height conditions and normal transportation requirements that apply to each road affected by transmission line crossings.
 - b. In design of the vertical clearance on some roads, particularly for coastal forest operations, special consideration may need to be given to transport of specialized over height forestry equipment such as a grapple yarder (swing yarder) or a line loader on an off-highway low bed with the gantry up (i.e., fully assembled), or with the gantry down, as appropriate.
 - c. Other information about transporting a grapple yarder is available from WorkSafeBC at: http://www.worksafebc.com/publications/health_and_safety/by_topic/assets/pdf/grapple_yarder.pdf



Photos: Courtesy of Western Forest Products Inc.

3. **Meet minimum vertical clearances:** Transmission line clearance to the travelled road surfaces will be such that clearance to any part of vehicles or equipment normally expected to be in transit along that road are at or greater than the levels that would compel special involvement of the owner of the power system or encroach on the clearance minimums indicated by WorkSafeBC. The vertical clearance of overhead transmission lines must consider the requirements of the **Canadian Standards Association (CSA)** and the **BC Occupational Health and Safety (OHS) Regulation** for overhead transmission lines and electrical installations. **Refer to clauses 6 and 7 below.**
4. **Consider opportunities to make transmission lines conspicuous to workers:** Consider opportunities to make transmission line crossings conspicuous to workers moving vehicles or equipment along roads or involved in helicopter yarding operations within areas of forest development. Install adequate advance warning signs of such crossings as appropriate.
5. **Retain as-built file records:** As-built file records of the equipment type, configuration, height and the designed transmission line to road clearance should be retained by the power project proponent, the ministry district office, and the owners of the power system. This information should be available to present or future forest agreement holders and other industrial users of the roads at their request.
6. **Meet CSA standards of transmission line design to establish minimum vertical clearance:** The minimum vertical clearance of all overhead transmission line crossings will vary significantly depending on location and design factors. Some of the key design factors include the transmission line voltage level, worker safety, height of equipment for harvesting operations and its related movement and transport and other types of industrial traffic that may reasonably be expected to use the forest road. In designing the transmission lines, the design vertical clearances are to consider the requirements of **CSA Standard C22.3 No. 1** to provide for safe vehicle or equipment passage under the energized transmission lines.
7. **Meet OHS Regulation section 19.24:** In designing the transmission lines, the design vertical clearances must meet at least the minimum clearance distance established for the situation of a person moving or involved in moving equipment (e.g., logging trucks, or harvesting equipment) under exposed electrical equipment and conductors (e.g., under transmission and distribution lines) and the person is not performing any work other than work related to moving the equipment.
 - a) **Section 19.24.2 and Table 19-1B of the OHS Regulation:** Minimum vertical clearances of overhead transmission lines (for the above situation) are specified in section 19.24.2 and Table 19-1B of the OHS Regulation for a range of voltage.
 - b) **WorkSafeBC interpretive guidance:** WorkSafeBC has prepared interpretive guidance on the application of section 19.24 of the OHS Regulation. This guidance can be obtained from WorkSafeBC's website. To facilitate easy reference, a relevant excerpt is provided in Appendix 2. For full and current WorkSafeBC guidance, refer to:
<http://www2.worksafebc.com/publications/OHSRegulation/Part19.asp#SectionNumber:19.24>

Further Information

If there are any questions about the content of this bulletin, please contact the following Victoria Engineering Group (Engineering Branch) professional engineers:

Glenn Moore	Senior Structures & Roads Engineer	(250) 387-1285	Glenn.Moore@gov.bc.ca
Brian Chow	Chief Engineer	(250) 953-4370	Brian.Chow@gov.bc.ca

Appendix 1
Example Grapple Yarder Equipment Height Diagram

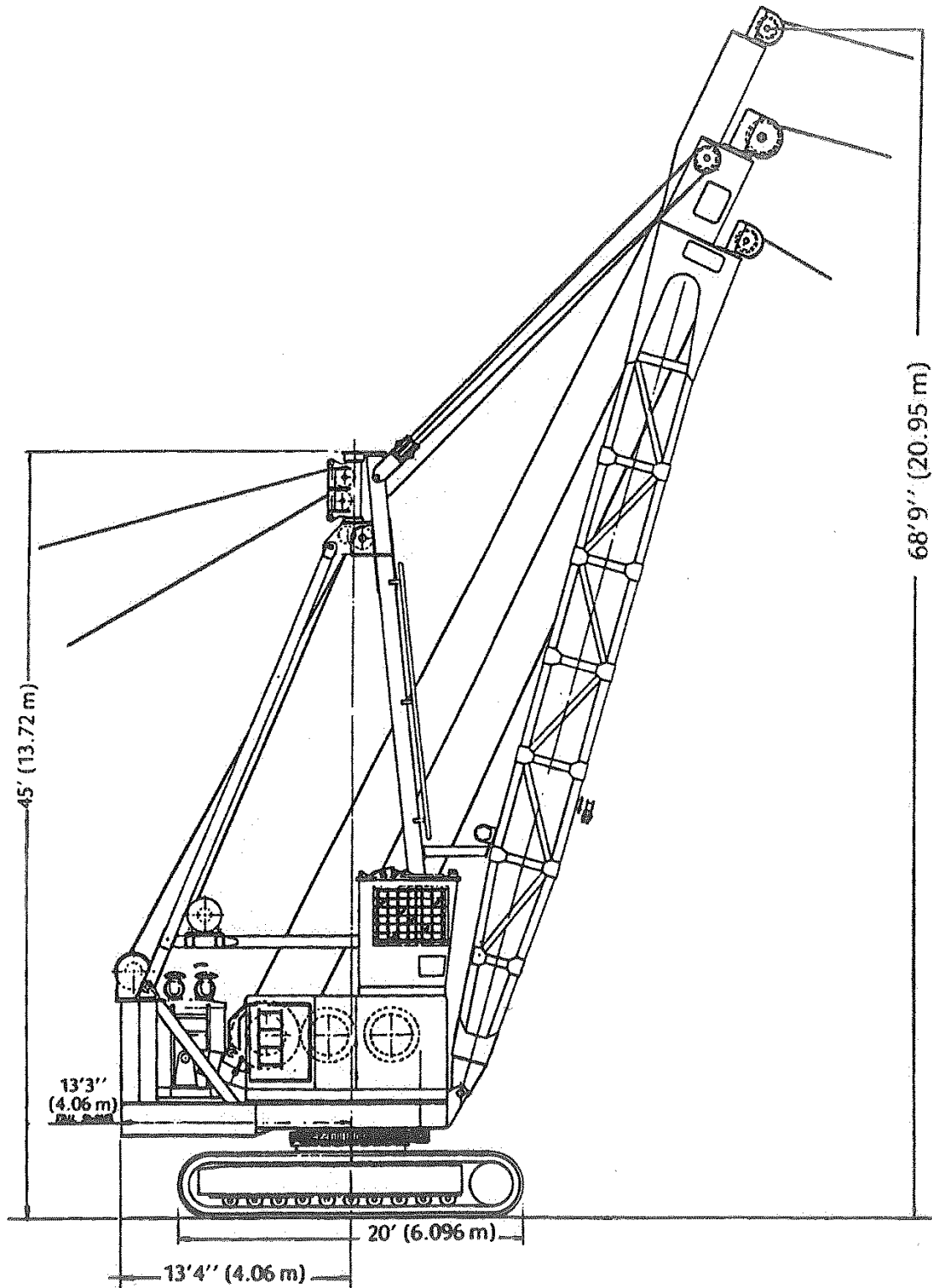

Madill 143 Interlock Swing Yarder

Appendix 2

This excerpt was copied from the WorkSafeBC website on March 16, 2012. For full and current guidance, refer to: <http://www2.worksafebc.com/publications/OHSRegulation/Part19.asp#SectionNumber:19.24>

Guidelines Part 19 - Minimum separation distance to be maintained from energized high voltage electrical equipment and conductors

G19.24.1 Minimum approach distance

Issued June 29, 2005; Editorial Revision to include February 1, 2011 regulatory amendment

Regulatory excerpt

Section 19.24.1 of the *OHS Regulation* ("Regulation") states:

Subject to section 19.24.2, or unless otherwise permitted by this Part, if exposed electrical equipment or conductors at a workplace have a voltage within a range set out in Column 1 of Table 19-1A, the following must remain at least the distance from the exposed electrical equipment and conductors that is set out in Column 2 opposite that range of voltage:

- (a) a person working at the workplace;
- (b) a tool, a machine, material or equipment at the workplace.

Column 1 Voltage	Column 2 Minimum approach distance for working close to exposed electrical equipment or conductors	
	Metres	Feet
Phase to phase		
Over 750 V to 75 kV	3	10
Over 75 kV to 250 kV	4.5	15
Over 250 kV to 550 kV	6	20

Purpose of guideline

This guideline describes the application of Table 19-1A minimum approach distances.

Application of section

This section of the *Regulation* applies to all workers unless the exceptions specified in sections [19.24.2 to 19.29](#) and [19.34](#) of the *Regulation* apply. The employer has a responsibility to provide workers with and instruct them in safe electrical work practices if the intended work may lead to an encroachment on the general limits of approach to energized high voltage equipment and conductors, as allowed by the exceptions to the general limits of approach under sections [19.25 to 19.29](#) and [19.34](#).

Therefore the employer must ensure either of the following:

- The limits of approach specified in Table 19-1A are maintained
- The additional requirements of the relevant sections of [19.24.2 to 19.34](#) are met

For minimum clearance distances related to moving equipment under exposed electrical equipment or conductors, see *Regulation* section [19.24.2](#) and guideline [G19.24.2](#).

G19.24.2 Minimum clearance distance when passing under electrical equipment and conductors NEW

Issued February 1, 2011

Regulatory excerpt

Section 19.24.2 of the *OHS Regulation* ("Regulation") states:

(1) This section applies in the circumstances where a person working at a workplace is moving or is involved in moving equipment under exposed electrical equipment or conductors and is not performing any work other than work related to moving the equipment.

(2) Unless otherwise permitted by this Part, in the circumstances set out in subsection (1), if exposed electrical equipment or conductors have a voltage within a range set out in Column 1 of Table 19-1B, the following must maintain at least the clearance distance from the exposed electrical equipment and conductors that is set out in Column 2 opposite that range of voltage:

- (a) a person moving or involved in moving the equipment under the exposed electrical equipment or conductor;
- (b) the equipment that a person referred to in paragraph (a) is moving;
- (c) the load carried by the equipment referred to in paragraph (b).

Table 19-1B		
Column 1 Voltage	Column 2 Minimum clearance distance for passing under exposed electrical equipment or conductors	
	Metres	Feet
Phase to phase		
Over 750 V to 75 kV	2	6.5
Over 75 kV to 250 kV	3	10
Over 250 kV to 550 kV	4	13

Purpose of guideline

This guideline describes the application of this *Regulation* section and describes examples.

Application of the regulatory requirement

Regulation section [19.24.2](#) provides an exception to section [19.24.1](#) when a vehicle or mobile equipment is being driven, provided the worker driving the vehicle or mobile equipment is not doing any work other than driving the vehicle or mobile equipment. The exception provides that the minimum clearance between a worker, any part of the vehicle or mobile equipment, or its load, and the exposed energized high voltage electrical equipment and conductors may be reduced to the limits in column 2 of Table 19-1B, subject to considerations in other sections in [Part 19](#). (These other considerations are the different limits of approach for qualified electrical workers or specially trained and/or qualified workers following appropriate safe work procedures acceptable to WorkSafeBC.)

The minimum clearance distances in column 2 in [Table 19-1B](#) are based on consideration of the applicable standards published by organizations such as the Institute of Electrical and Electronics Engineers, as well as advice from electrical utility companies.

Section [19.24.2](#) includes application to vehicles hauling oversize loads on industrial sites or along haul roads. For example, off-highway log hauling trucks generally have loads higher than trucks hauling on public roads, and the employer or prime contractor will need to know and control the maximum load height for such off-highway log trucks as necessary to ensure the clearance specified in column 2 of Table 19-1B is maintained. Similarly, when equipment such as a log loader or feller/buncher is being driven from one work location to another, the employer will need to ensure the height of the equipment in the configuration being used when travelling or driving the equipment will allow it to pass under any overhead high voltage conductors by at least the clearance specified in column 2 of [Table 19-1B](#).

The height of heaped loads on earth or rock hauling trucks also needs to be known and controlled to ensure the top of such loads can pass under any overhead conductors by at least the clearance specified in column 2 of [Table 19-1B](#). When a truck box is raised to dump or spread material, the driver is doing more than just driving the vehicle and the clearance distances in column 2 of [Table 19-1A](#) apply. Refer to OHS Guideline [G19.24.1](#) for minimum approach distance for working close to electrical equipment and conductors.

It is expected that road maintenance vehicles, such as road graders and trucks rigged up for snow plowing, salting/sanding, or dust suppression operations will have overall heights that ensure clearance to the limits in column 2 of [Table 19-1A](#) during grading, plowing, or salting/sanding/spraying operations. A worker grading a surface, or plowing snow, salting/sanding, or spraying water or other road treatment on a surface is considered to be doing more than just driving the vehicle or equipment.

If a vehicle or mobile equipment stops under exposed energized high voltage electrical equipment or conductors, then the clearance distances in column 2 of [Table 19-1A](#) apply.