

Guidelines for Establishing Transfer Stations for Municipal Solid Waste

This guideline is based on a report prepared for the Ministry of Environment, Lands & Parks (now called Environment) by UMA Engineering Inc. of Victoria, BC in fulfillment of a ministry funded project. The views and ideas expressed in this guideline are principally those of the contractor and reflect the ministry's position. However, mention of trade names, commercial products or supplier names does not constitute endorsement or recommendations for use by the ministry.

The Branch intends that the document be used to assist regional districts, municipalities and their consultants in the establishment of transfer station facilities during the implementation of solid waste management plans.

Section 1 Introduction

Transfer stations are facilities at which municipal solid waste is dropped off by relatively small vehicles, loaded into larger containers or onto larger vehicles, and hauled to an off-site management facility for further processing or final disposal. There are many different methods and combinations of methods for solid waste transfer. The purpose of this report is to describe transfer station methodologies, illustrated by examples in British Columbia and Alberta, and to recommend siting, design and operational guidelines for establishing transfer stations. A second purpose is to provide cost models that compare direct haul in collection trucks with transfer haul to a landfill, and that compare rural landfills with rural transfer stations. It is intended that these cost models be used as an aid in deciding whether a transfer station is justified in given, particular conditions.

Section 1.1 General

There are two principal reasons for constructing a transfer station:

- **Economics** - If the destination of the wastes is far away from the area in which they are collected, then it may be more economical to transfer the wastes to large vehicles for haulage than to haul them directly in the original collection vehicles. This situation is becoming increasingly common, as landfills become more difficult to site and, therefore, more remote from populated areas.
- **Service** - For a rural area without a garbage collection service, a transfer station is often provided as a service to local residents, so that they do not have far to drive to drop off their wastes. A transfer station is often established at a landfill after it has been closed because people are accustomed to taking their waste to that location. Such a transfer station may or may not be economical.

Ideally, a transfer station should be sited as close as possible to the centroid of the population served, in order to minimize collection costs, or some distance along the haul route to the landfill. The transfer station should be sited and operated so as to create no environmental or health hazard, and no nuisance.

Section 1.2 Transfer Station Systems

1. **Green Box** - This rural system is shown in [Figure 1](#), at the end of this section. It is similar to that used for commercial establishments in urban areas. Metal containers with hinged lids, varying in size from 2.3 to 6.1 cubic metres (three to eight cubic yards) are placed at strategic locations such as cross-roads, city works yards and rural stores. The containers are picked up and emptied by front, rear, or side loading compaction trucks. One cubic metre of packer truck capacity would equal about three cubic metres of bin capacity. Therefore, as an example, a 22 m³ truck could service eleven 6 m³ bins on one trip.

Although economical in terms of capital cost, the relatively small bins are unable to accommodate large items such as furniture and demolition/land clearing/construction (DLC) waste. They are awkward to use because waste must be lifted up to be dumped. A problem with multiple bins (i.e. more than three) is that people become frustrated on finding successive bins full, and may dump their waste indiscriminately. A transfer station employing small bins is normally considered suitable only for small annual tonnages, say less than 100 tonnes/year, and for serving areas that have some other convenient alternative for disposing of bulky waste.

2. **Dedicated Truck** - Some rural areas have found it convenient to arrange for a compaction waste collection truck to be available at a specified location, on a regular schedule, for an advertised time period, usually once per week. Local residents bring their waste to the truck, and are charged a prearranged rate per bag or can by the truck driver. Although this system is not a "transfer station" it can be a substitute for one, and has the advantages of requiring no capital cost, assuming a collection contractor is available, only minimal operating cost for a subsidy and advertising, and users pay much of the cost directly for the service. The major disadvantages are that it is relatively expensive, and that service can usually only be afforded for limited periods, say one day per week or less.

3. **Rolloff Container** - This rural system, illustrated in [Figure 2](#), uses large steel containers, typically varying from eleven to thirty-eight cubic metres (fifteen to fifty cubic yards). Full containers are picked up by a rollon/rolloff tilt frame truck, and transported singly or in pairs by a truck/pup

arrangement, to the landfill. An empty container is deposited by the same truck that picks up the full one. Rolloff bins often achieve their legal load limit without compaction. For example, the legal payload for a 38 m³ (50 cu yd) bin is about 8 tonnes, which is equivalent to a density of about 210 kg/m³.

The best rolloff station designs incorporate elevated ramps, with the bins sitting at a lower level, so that waste can be dropped down into the bin, and hinged counterweighted lids that are easy to move. A sheet metal or screened cover is often used over the bin to reduce blowing litter and exclude birds and animals. Site development can include fencing, a lockable gate, and paved roads.

This system is fairly economical in terms of capital cost, is capable of accepting all household solid waste, is uncomplicated, is flexible because more containers can be added when volumes increase, and is generally well accepted by the public. However, the bins cannot successfully receive waste from standard collection trucks. These trucks must direct haul to the landfill. Scheduling is the major concern with this system. Haul costs can be high because containers may not be completely filled. In summary, rolloff stations are the most common and accepted system in BC.

4. **Hydraulically Tippable Containers** - These come in a wide range of sizes. The smallest are up to three cubic metre roadside units that use a quick-connect hydraulic system on a side loading collection truck to tip the bins into the truck. Larger units, as shown in [Figure 3](#), with a capacity of about thirty cubic metres, use their own hydraulic system to tip their contents into a large transfer trailer, typically holding 90 m³, and hauled by a tractor. The large units are set up similar to rolloff stations, with a ramp leading to an upper level, so that waste can be thrown down into the container. The transfer trailer parks at the lower level to receive waste. The advantages of this type of system, compared to a rolloff system, are that it can receive waste from standard collection trucks, and that only the waste is hauled. The expense of hauling containers is avoided. Disadvantages of this system, compared to rolloff bins, are problems caused by cold weather on the hydraulic cylinders, potential damage to the hydraulic systems resulting from vandalism and fire, and problems that arise from overloading with heavy material, which becomes jammed in the hopper.

5. **Direct Dump** - Sometimes called a "push pit" system, these urban transfer stations, as shown in [Figure 5](#) at the end of this chapter, allow waste collection trucks to dump their loads either directly to a large transfer trailer parked at a lower level, or to a tipping floor, from which it is usually pushed by a loader or Bobcat into a 90 m³ trailer. A variation on this theme is for the waste to be lifted from the tipping floor or bunker by a crane, thus eliminating the need for a lower level for the transfer trailer. The tipping floor and trailer are usually housed in a building. Other amenities generally provided at a

larger station include weigh scales, bins for receiving recyclables, a storage area for white goods, and an office, washroom, and lunchroom for staff.

6. **Compaction** - The use of compaction at a transfer station may be economically advantageous, since it allows a greater weight to be hauled in a given container. The economic viability of compaction depends on the nature of the wastes, the type of vehicle used to collect wastes, and the distance from the transfer station to the landfill. Wastes containing a significant amount of dense material, and/or waste collected in packer trucks (even though it rebounds upon dumping) may already achieve legal truck weight limits without compaction. The fundamental question in deciding whether to use compaction or not is this: Can the legal gross vehicle weight of the transport units be reached without compaction?

Compactors may be used even at small facilities. Rolloff compactors are available and are sometimes used at rural transfer stations, as shown in [Figure 4](#). These compactors typically achieve a compaction ratio of about 6:1. They are limited as to the size and type of waste they can accept, so often a standard rolloff container is provided to receive bulky objects and demolition debris. There is a variety of compactors available for urban direct dump transfer stations; waste may be compacted directly in the trailer that receives it, or in a separate receiving compactor that then discharges to the transfer trailer.

Figure 1. Typical Green Box Site

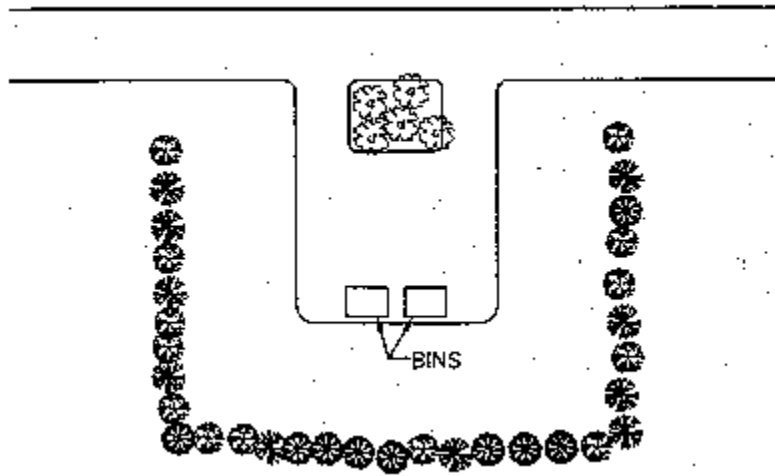
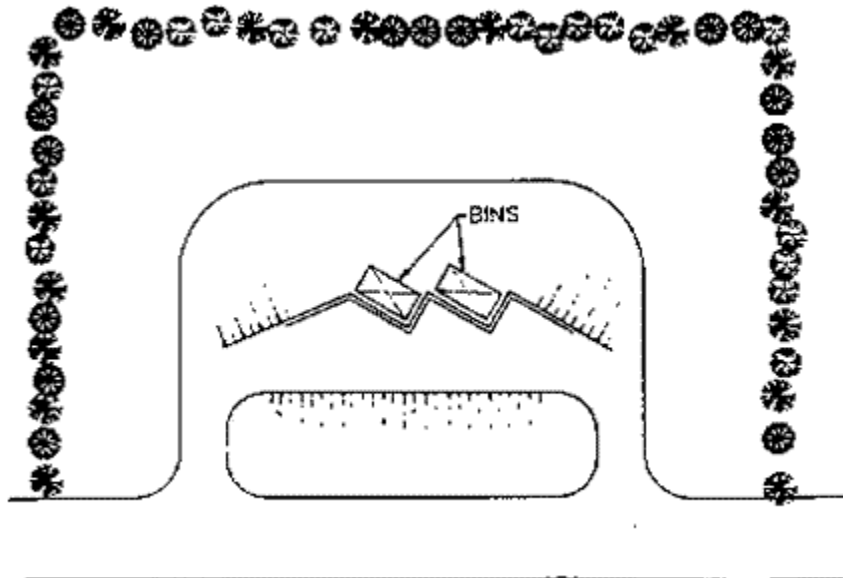
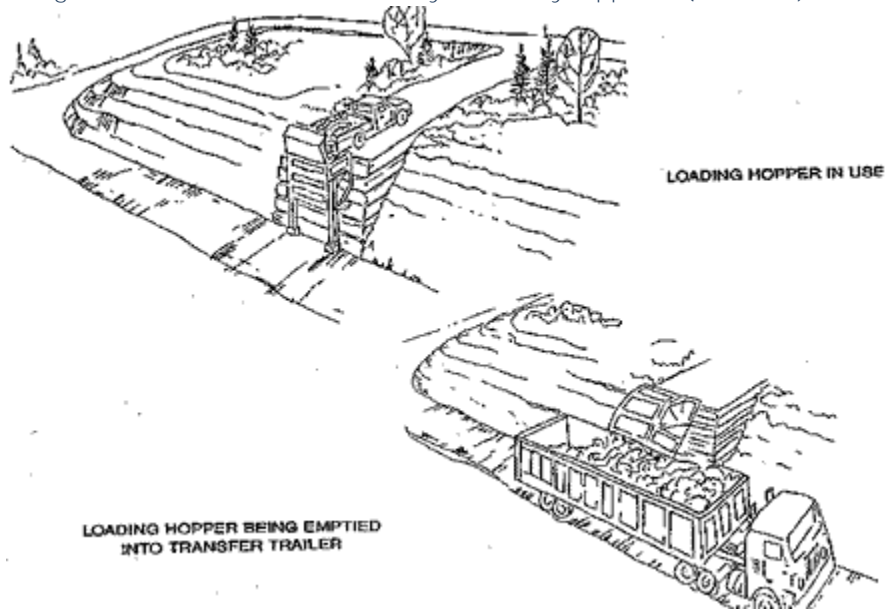

Figure 2. Typical Roll-off Bin Site



Adapted from Alberta Environment Transfer Station Manual

Figure 3. Transfer Station with Hydraulically Tippable (Transtor) Bin



Adapted from Alberta Environment Transfer Station Manual

Figure 4. Typical Compaction Type Rolloff Facility

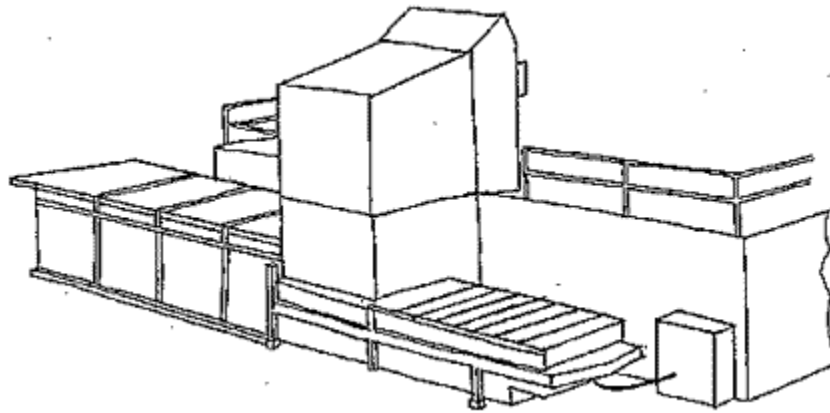
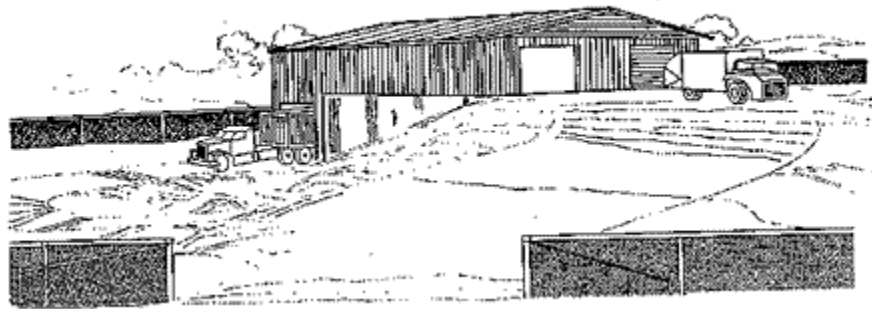

Figure 5. Transfer Station Push Pit System



Guidelines for Establishing Transfer Stations for Municipal Solid Waste

Section 2.1 General Location

It is desirable that a transfer station be located near the centroid of the population to be served, and near a major haul route to the destination landfill. The specific location of a transfer station shall be described in the Regional Solid Waste Management Plan, and should be acceptable to the majority of the public and the regional district board. As required in the Guide to the Preparation of Regional Solid Waste Management Plans by Regional Districts (BC Environment, 1994), if a new station is proposed, and is not included under an approved Plan, then an amendment to the Plan shall be prepared, documenting the public discussion and acceptance of the site.

The location of solid waste management facilities, including transfer stations, in relation to the presence of indigenous and migratory wildlife, is an issue of increasing importance as the activities of human beings intrude more heavily into the traditional habitat of bears and other wildlife. It is important that attention be paid to avoiding areas of high concentration of wildlife, such as migratory paths and other high use/high presence locales, in the siting of transfer stations and other solid waste management facilities. Local staff in the ministry's regional wildlife sections should be consulted for information related to a specific site under consideration as well as for advice as to general areas to be avoided.

Location has a strong influence on the cost of operating a transfer station, on its convenience to the public and on operational problems associated with wildlife such as bears. Notwithstanding these issues, suitable land may not always be available in the best general location or may not be acceptable to the public.

Section 2.2 Area Requirement

Sufficient area should be provided for existing needs and buffers, but also for potential future expansion. The planning horizon for the provision of transfer services at a particular site, or at an alternative site, should be a minimum of 20 years, or consistent with the applicable Regional Solid Waste Management Plan.

Section 2.3 Zoning

The selected site should conform to local zoning bylaws relative to land use, and building heights and setbacks. Appropriate land use designations include industrial, commercial, institutional, and agricultural. Residential zoning may be appropriate in areas where the lots are large, and where the station is accepted by the local residents.

Section 2.4 Buffer

A vegetated or landscaped buffer zone of at least 15 metres should be left around the perimeter of the active transfer area, in order to minimize any potential nuisance associated with noise, dust, or odours, or any objections based on visual aesthetics. For small, unmanned, rural stations adjacent to forested areas, and where there is a threat of fires being set in the waste containers, an additional buffer zone may be desirable. In this situation, it would be appropriate to provide a cleared firebreak of 35 metres between the waste bins and the vegetated buffer.

Some flexibility should be allowed, based on local conditions and adjacent land use.

Guidelines for Establishing Transfer Stations for Municipal Solid Waste

Section 3: Design Guidelines

Section 3.1 Quantity Estimation

Solid waste quantities anticipated at a transfer station should be based on estimates for the area to be served. These estimates are normally contained in the Regional Solid Waste Management Plan. These estimates are usually given in tonnes per year. Since a transfer station is concerned with the volume of waste that must be received, held, and transported, the estimated annual tonnage should be converted to cubic metres. Where local density information is not available, a conversion factor of 150 kg/m³ may be used for standard, uncompacted municipal refuse. Compacted refuse may have a density of 2 to 4 times greater, but waste discharged from a packer truck does tend to "spring back" and reduce its density again. For a station receiving about half of its waste from packer trucks, a density of about 200 kg/m³ may be assumed.

The annual tonnage or volume should be used as a basis to calculate the average daily quantity, based on the number of days that waste is received at the station. A peaking factor should then be applied, to convert the average daily quantity to a peak daily quantity. It is often useful to calculate an estimated peak weekly quantity as well, particularly for small stations, that may only haul waste weekly. Failure to provide for peak volumes may result in premature filling of the containers to the point of over-flowing, an unplanned for increase in haulage (and the associated costs) and unsightly conditions at the site.

Local conditions are very important in determining densities and peaking factors. For example, local building demolition activity can contribute high density wastes. The appropriate peaking factor can vary widely, depending on local waste stream components and population characteristics. Areas with large seasonal tourist populations or seasonal agricultural activities can have high peaking factors. For these reasons, average and peak quantities must be estimated in the context of local conditions, with reference to the Regional Solid Waste Management Plan.

Section 3.2 Storage Volume

A transfer station must provide sufficient volume, between one waste pickup and the next, to ensure that the bins or transfer trailer provided do not fill to overflowing. A direct dump station must provide sufficient tipping area to accommodate the numbers and types of vehicles arriving, their unloading times, and any waste sorting or processing that is to be done. Sufficient volume must be provided to accommodate peak waste periods, statutory holidays, and long weekends. Storage volume provided

and pick-up frequency are essentially a trade-off. For a given population served (or waste generation rate), the larger the storage volume provided, the less frequent the waste pickups.

Bulky Goods

In some cases, acceptance of bulky goods such as appliances, auto hulks, furniture and wood wastes at transfer stations may provide the most convenient and practical method to the public for handling these types of wastes. Volume (space) provisions should be made for storing these wastes, if they are accepted at the site. Failure to provide bulky goods services may result in these items being placed in transfer station bins, resulting in inefficient use of bin space, premature filling of the bins to the point of over-flowing, more frequent hauling and an associated increase in operating and haulage costs. For transfer station sites in remote locations, the option of requiring the public to haul bulky items to a regional landfill site may be too onerous.

If bulky items are accepted at a transfer station site, they should be segregated to dedicated storage piles/containers. The piles, if kept properly clean of contaminants, could be allowed to build-up until economical loads are available for transport. The time period before economical loads are available for transport could be several months to several years.

Section 3.3 Access Roads

Roads to a transfer station site and within the site should be designed to provide all season, all weather access. The minimum road width should be 8 metres. Designs must be in accordance with standard practice for the anticipated traffic volume and speeds. Sufficient space should be provided for queuing, such that vehicles need not stop on a public road or highway when entering the site. Traffic flow through the site should be considered. Gravelled surfaces may be acceptable, depending on the local context, but if dust or mud is a problem, asphalt paving should be provided.

Section 3.4 Surface and Ground Water Quality

Provision should be made to prevent stormwater and runoff from contacting waste. All waste containers should be leak-proof, or should provide for the collection of contaminated water and illegally dumped liquids. Tipping floors should provide drains and sumps to collect washdown water and illegally dumped liquids. Proper disposal of contaminated water should be ensured.

Section 3.5 Weigh Scales

Transfer stations serving populations of 5,000 or more, or receiving 5,000 tonnes / year or more, should install weigh scales. Smaller stations should consider installing weigh scales or using an alternative (ministry approved) method of measuring waste quantities received, or instituting charges per vehicle or waste container, as a means of allowing the collection of tipping fees and thus of paying the costs of staffing and operating the station. The accuracy of specific scales or types of scales, for the purpose of charging fees, should be confirmed with the federal department of Consumer and Corporate Affairs - Weights and Measures.

Section 3.6 Wildlife Control

Perimeter fencing, such as the chain link variety, is the first defence against wildlife intrusion. Bear-proof electric fencing has been used with success for both black bears and grizzly bears at several landfills in the province and should not represent a prohibitively expensive alternative for the small perimeters associated with most transfer stations. Electrifying the normal perimeter security fence may be feasible, with appropriate attention to warning humans of its presence, such as by using signs and other measures, and otherwise ensuring it is safe and user friendly. Careful attention must be paid to gate design, on the one hand to promote responsible use by humans (including both easy access and after use closure) while at the same time to prevent wildlife from entering the site.

Containers intended to receive organic waste should have lids, screens, or covers that will prevent access by bears and other predators, rodents, and birds. Alternatively, containers may be placed inside predator-proof enclosures that provide both easy access to users and promote closure after use (e.g., garage door type designs). Consideration should also be given to washing out containers between uses, either at the transfer station or at the landfill. Only sturdy, easily cleanable, animal-proof containers should be used. Buildings at direct dump facilities should be designed to minimize areas/spaces that afford a harbour for rats and other small mammals, and to be predator-proof. The importance of predator-proof containers cannot be over-emphasized as this design feature will prevent rewarding wildlife with a food source in the event that the exterior fencing is breached (e.g., by a gate left open, etc.).

Section 3.7 Site Security

Fencing should be provided around the perimeter of the site, with a lockable gate at any entrance point. The type of fencing may vary with the natural site features.

Section 3.8 Signs

Transfer stations should be provided with a sign (or signs) posted prominently at the entrance, that contains the following information:

- facility name
- owner / operator with phone number and address
- emergency phone numbers for fire, police and medical assistance
- hours of operation (if applicable)
- prohibited materials
- materials accepted for recycling
- tipping fee schedule (if applicable)
- the presence of an electric fence (if applicable)

If recyclables are not accepted at the station, a sign should indicate the location of the nearest facility that does accept them. In addition, the sign should indicate locations, if known/available, where prohibited materials such as paint, used oil, lead-acid batteries and other items can be safely taken.

Section 3.9 Water Supply

For facilities with buildings, employing staff during operating hours, water for fire protection should be provided in accordance with the *Water Supply for Public Fire Protection — A Guide to Recommended Practice*, as available through the Insurers Advisory Organization. For these larger stations, washdown water should also be provided.

Section 3.10 Materials Recovery

A transfer station is an ideal location to provide bins for the dropoff of reusable and recyclable materials. Similar design considerations apply as for waste; the station should provide sufficient storage space, weigh scales and fire protection for larger stations, and signs giving users appropriate instructions. The dropoff of organic materials for composting requires that the bins be emptied frequently, depending on the type of material. Yard waste containing a significant amount of grass should be picked up daily, unless it can be shown that odours are not a problem at either the transfer station or the composting site. Yard waste consisting mainly of brush and leaves may be picked up weekly. Food wastes should be picked up daily.

At some rural transfer stations, waste oil receptors and lead-acid battery bins (with alkali material placed in the bottom to neutralize spilled acids) have been provided. This allows the public a

convenient method of disposing of these materials which might otherwise be put into the transfer station bins.

In cases where recycling facilities are not located at the transfer station, a sign should be provided directing patrons to the nearest available facility.

Section 3.11 Safety Features

Most transfer stations involve the dropping or pushing of waste down into a bin or trailer. It is important that safety features such as guard rails be incorporated to prevent people from falling into a bin, and stop logs or bars to prevent vehicle accidents. Transfer buildings should be designed with sufficient ceiling clearance to accommodate the vehicles that may enter and dump. It is desirable that transfer buildings have clear spans, without central columns to impede traffic.

Guidelines for Establishing Transfer Stations for Municipal Solid Waste

Section 4: Operational Guidelines

Section 4.1 Prohibited and Difficult Wastes

The following wastes should not be accepted at a transfer station unless special arrangements have been made and appropriate containers provided.

- Hazardous wastes other than those specifically authorized in the Hazardous Waste Regulation.
- Bulk liquids and semi-solid sludges that contain free liquid.
- Liquid or semi-solid wastes including septage, black water, and sewage treatment sludge.
- Biomedical waste as defined in Guidelines for the Management of Biomedical Waste in Canada, CCME, February 1992.
- Dead animals and slaughterhouse, fish hatchery, and farming wastes or cannery wastes and byproducts.

Recyclables designated in the Regional Solid Waste Management Plan should be prohibited from disposal in bins or on a tipping floor intended for wastes.

A difficult issue to deal with is the enforcement of prohibitions at an unmanned site. All sanitary landfills are now required to have staff on site during operating hours, although landfills serving fewer than 5,000 people may be exempt, and all landfills are allowed to have waste bins outside the gates for after hours use. Only small transfer stations, accepting less than 1,000 tonnes/year, should be allowed to operate without staff during operating hours, a privilege that should be rescinded if problems develop.

Section 4.2 Waste Storage

The allowable maximum storage time depends on the type of waste, facility size, presence and type of wildlife, and season. Inert waste, such as demolition debris, may be stored for up to two months, given sufficient space. Small rural stations should not store municipal garbage for more than a week in the winter, or more than two days in the summer, unless it can be shown that longer storage will not cause problems. Transfer stations accepting more than 5,000 tonnes/year should transport all garbage off the premises at the end of every working day. Storage of municipal garbage outside of waste containers should be prohibited.

It is difficult to set firm rules for storage, because of widely varying circumstances throughout the province. In northern areas, where waste may stay frozen for months, long term storage may not be a problem. In some areas, the presence of bears that are accustomed to eating garbage may indicate a need for daily removal.

Section 4.3 Supervision

Operating staff should inspect every transfer station at least once per week. Stations receiving 1,000 tonnes/year or more of waste should provide an operator on site during operating hours. Facilities receiving 5,000 tonnes/year or more should employ staff at the scale house and on the tipping floor or in the bin area at all times during operating hours.

Even at the smallest stations, staff are required on at least an intermittent basis to ensure that prohibited wastes are not being dumped, that the facility is functioning properly, and that the site is being kept clean.

Section 4.4 Wildlife Control

Allowable measures for the resolution of wildlife problems at transfer stations will depend on the wildlife species and the severity of the problem. In most cases involving large predators and extreme measures such as poisoning rodents and other small mammals, it is necessary to involve ministry staff or specially trained personnel for the protection of human health and the environment. For large predators such as bears, wolves and coyotes that are or become conditioned to the site, alternatives include trapping and translocation of protected species and shooting of dangerous animals. The local ministry Conservation Officer Service should be consulted for problems related to bears and other large predators. The Conservation Officer will assess whether to attempt translocation or shooting in the case of persistent problems with individual animals. For problems related to rodents and other small mammals, physical methods such as trapping or snaring and poisoning are among the most common options. Physical methods (i.e.: traps, snares, etc.) may be used without ministry control. However, poisoned bait should be used only by personnel licensed and certified under the ministry's Pesticide Management protocols. Fish and Wildlife staff in local ministry offices should be consulted to provide guidance on protected species of birds and animals to prevent unauthorized or illegal poisoning or trapping.

The first priority is to prevent problems with wildlife by designing the station so that animal access is difficult, and by operating the station so that it is not attractive to animals and birds. The important elements are fencing, bin covers, site tidiness, and the prompt removal of wastes. Even with all these

elements in place, wildlife may be a problem at transfer stations, particularly those stations that replace small landfills, or stations that have been poorly run, and have provided food for wildlife in the past. Bears that have become accustomed to feeding on garbage can be a particularly difficult problem. As indicated in the design features section, internal measures (bin covers, site tidiness, prompt removal of waste) should not be sacrificed or compromised in favour of external measures (fences) as it is important that wildlife breaching the external measures are not rewarded by gaining easy access to the waste.

Section 4.5 Emergency Procedures

Transfer station staff should be familiar with procedures involving fire prevention and control. A "FIRE HAZARD - NO SMOKING" sign should be posted at the entrance or at the weigh scales. Fire extinguishers should be available inside all buildings and vehicles. Stations receiving 5,000 tonnes/year or more, or with permanent staff, should have telephone communications available to enable the fire department, police, or medical services to be contacted. Staff serving small stations should have a cellular telephone in their vehicle.

Staff should be trained in first-aid procedures. At stations where staff are present during operating hours, a standard BC #2 First Aid Kit should be available. Smaller first aid kits should be available in staff vehicles.

Section 4.6 Site Tidiness

Litter at small unstaffed stations should be cleaned up at least once per week. Cleanup at stations with permanent staff should be done every operating day, or as required. Staffed stations with weigh scales should consider charging users an additional fee if they arrive with improperly secured or improperly covered loads.

Section 4.7 Nuisance Control

The generation of dust can cause unsightly conditions, and may be irritating to transfer station staff and users. Dust may arise from roads, and from some refuse, such as concrete, demolition waste, ashes, and plaster. Consideration should be given to paving, watering, or brine-sealing unsurfaced roads, and sweeping surfaced roads. If dust problems arise from the handling of waste, consideration should be given to wetting the waste, or if within a building, to installing proper ventilation and dust collection.

Operational practices for reducing odours are the prompt removal of waste and the regular washing of floors, equipment and bins.

If noise is a cause for complaint by neighbours, it may be necessary to limit the operating hours of the station, and/or to provide better noise suppression on equipment and vehicles.

Section 4.8 Scavenging

Scavenging at transfer stations should be prohibited. However, if special arrangements have been made to set aside an area for the dropoff and safe storage of goods and materials, then controlled salvaging should be encouraged.

Guidelines for Establishing Transfer Stations for Municipal Solid Waste

Section 5.0 Costing and Comparison Models

This chapter provides capital and operating cost estimates for landfills and transfer stations, cost models to assist in making decisions on transfer haul versus direct haul, and transfer stations versus landfills, and on financing transfer stations. Detailed cost estimates are provided in a number of examples contained in Appendices [A](#) and [B](#). The capital costs contained in the first two sections of this chapter were estimated for mid-1994, for a projected Engineering News-Record Construction Cost Index of 5350. The cost examples provided must be used with care, because unit cost information varies throughout the province. Readers are encouraged to investigate local prices for similar work in their area.

Section 5.1 Landfill Costs

In order to create a model to assist in the decision of whether to close a landfill and replace it with a transfer station, it is first necessary to define the capital and operating costs associated with different types and sizes of landfills. Detailed example cost estimates are contained in Appendix A, for landfills accepting 100, 1,000, 10,000, and 100,000 tonnes/year of waste. Estimates are provided for sites where leachate is naturally attenuated and for sites requiring engineering management of leachate. All estimates include elements needed to enable the landfills to meet the BC Landfill Criteria for Municipal Solid Waste. [Table 1](#) summarizes the total annual cost of the landfill examples contained in [Appendix A](#).

The fencing component of the capital costs allowance included in the total annual cost data summarized below does not provide for electric predator/bear-proof fencing. An additional cost of \$12-\$20 per metre of fenced perimeter should be added to allow for this option.

Table 1. Example Landfill Costs

Capacity	Example Landfill Type	Total Annual Cost (\$)	
100	A. Natural Attenuation	\$	82,800
	B. Engineered Landfill	\$	116,400
1,000	C. Natural Attenuation	\$	132,700
	D. Engineered Landfill	\$	254,800
10,000	E. Natural Attenuation	\$	509,900
	F. Engineered Landfill	\$	808,400
100,000	G. Natural Attenuation	\$	1,257,700
	H. Engineered Landfill	\$	2,792,600

Section 5.2 Transfer Costs

This section provides a summary of capital and operating cost estimates for idealized transfer stations that would meet the guidelines recommended in Sections [3](#) and [4](#). The detailed example estimates are contained in [Appendix B](#). These example cost estimates for stations of different sizes and types are intended to supply enough information for readers to adapt a given example to their own specific circumstances.

Capital cost estimates contain the following elements:

1) **Land Purchase** - The example sites contain a 15 metre buffer strip, and are assumed to be purchased at a cost of \$25,000 per hectare. This cost is intended to be conservative, and may be much lower in many areas. Frequently, Crown Land may be leased or used at little or no cost.

2) **Site Preparation** - Typical lump sum costs for clearing, grubbing, and site grading were assumed. However, if stumps and other wood debris are chipped and spread on site or removed from the site for chipping, the costs may increase.

3) **Access Road and Ramp** - Cost estimates were provided only for internal access roads, not roads leading to the site. The ramp referred to is for the bin sites, where access is required for users to drop waste down into the bins. The estimates are for the spreading of 150 mm of crushed gravel on the road and ramp surfaces, at \$8.00/m².

4) **Retaining Wall** - A retaining wall is provided for a rolloff bin site, such that the bins sit along the base of the wall. Five possible types of wall were considered; reinforced concrete, concrete lock blocks, bin wall (e.g. Armco), railway ties or other wooden material, and old vehicle tires. Wood and tires are not recommended because of their susceptibility to fire damage, and because of their probable higher cost in the long term. Cost estimates were prepared for the other three possibilities, in Example A in Appendix B, for a 100 tonne/year rolloff bin station. The concrete lock blocks were the most economical, at an estimated \$7,000, compared to \$13,000 for reinforced concrete and \$16,000 for bin wall.

Lock blocks are provided by United Lock Block, which has 72 sales locations in BC. In addition to being economical, they provide some flexibility in that they can be salvaged and relocated if necessary. The purchase cost per block, including tax, varies from about \$70 to \$105 around the province. Freight depends on location and number of blocks ordered, but would typically be \$15 to \$30 per block. Installation was assumed to require a crane and two men, at about \$150/hour, for about \$30 per block. A total cost per installed block of \$160 was assumed in the examples.

5) **Concrete Pad** - Rolloff bins work best on a hard surface. The estimates for rolloff stations include a reinforced concrete pad along the base of the retaining wall, of about 1.5 times the width of the bin, 150 mm thick, at \$100/m².

6) **Bins** - The large rolloff bins, with 38 m³ capacity, are estimated at \$5,500 each. This price does not include a lid or cover. The small 5 m³ bins used in another example are estimated at \$1,000 each, and the small hydraulically tippable bins of 3 m³ (HaulAll Hyd-a-way), at \$3,500 each. A price of \$33,000 was allowed for a large 31 m³ hydraulically tippable bin (Transtor). Compactor rolloff bins, with 38 m³ capacity, are estimated at \$24,000 each.

7) **Rolloff Bin Lids or Covers** - Hinged lids for rolloff bins were estimated at approximately \$4,000 each. These lids (and the associated costs) were not included in any of the example estimates, as they are an option that may not be appropriate at all locations. Although providing a potential means of excluding precipitation and preventing wildlife from accessing the bin, there are some operational concerns with their use. They can be awkward for people to use, snow and ice can make the lids

heavy and difficult to open and people often leave the lids open after use, which allows access by animals.

Predator-proofing transfer stations is a key issue for sites in areas of bear activity. This can be accomplished through a variety of design and operating features, including external fencing, predator-proof containers and/or lids, site tidiness and prompt removal of accumulated wastes.

An alternative to predator-proof containers/lids is to enclose the bins with sheet steel structures with rollup or sliding doors and mesh predator barriers, such as manufactured by Northside Steel Fabricators in Kelowna. The cost of one of these structural steel covers, plus two days for a crane and two men to erect it, was estimated at \$16,000.

8) **Fencing, Gate and Signs** - Fencing was assumed to be installed around the perimeter of the site, at a cost of \$35/lineal metre. \$200 to \$300 was allowed for a sign. The capital cost estimates provided for fencing do not include provision for electric predator/bear-control fences. An additional cost of approximately \$12-\$20 per metre of fenced perimeter should be added to allow for this option.

A contingency allowance of 10% was allowed for in each example, plus an allowance for engineering of between 5% and 15%, depending on the complexity of the station. In each example, the capital cost estimate was converted into an annual cost by assuming payback over a ten year period at 8% interest.

Operating Cost estimates include the cost of running the transfer station itself, and the cost of hauling waste to a landfill. The following unit costs were used: labour, \$20/hr; front end loader, \$65/hr; rolloff truck with single bin, \$100/hr; rolloff truck with pup (two bins), \$110/hr; transfer tractor and trailer, \$100/hr; top loading commercial packer truck, \$135/hr; Shu-pak or other small compactor truck, \$90/hr. An allowance of 10% was added to each total operating cost, for administration.

[Table 2](#) summarizes the total annual cost for each example transfer station. The cost includes capital payback plus the cost of operation and maintenance.

Based on the example estimates, for a 100 tonne/year station, the cost of using multiple small bins is almost the same (Example B), or considerably more expensive (Example C) than using rolloff bins (Example A). The use of multiple small bins is also problematic; people become frustrated on finding a bin, or successive bins, full and throw their garbage anywhere. Furthermore, small bins do not allow

for the disposal of bulky items. Multiple small bin systems may be appropriate for very small annual tonnages, but not for 100 tonnes/year or more.

Example D consists of a packer truck, designated to be available at a specific location for one day per week. People bring their waste to the truck. This system is expensive but it avoids any capital costs or siting commitments. It may be a suitable stopgap measure to institute until a more economical alternative can be implemented. It provides a low level of service, but does allow the truck operator to collect fees and to reject inappropriate wastes.

Table 2. Example Transfer Station Costs

Capacity (tonnes/year)	Example Transfer Station Type	Total Annual Cost (\$)
100	A. Rolloff	\$ 27,800
	B. Green Box	\$ 28,100
	C. Hydraulically Tippable (Hyd-a-way)	\$ 35,600
	D. Dedicated Truck	\$ 41,400
1,000	E. Rolloff	\$ 104,600
	F. Hydraulically Tippable (Transtor)	\$ 94,300
10,000	G. Direct Dump	\$ 522,600
	H. Compaction Rolloff	\$ 548,900
	I. Hydraulically Tippable (Transtor)	\$ 459,300

At 1,000 tonnes/year and at 10,000 tonnes/year, for the example estimates, economics appear to favour the Transtor type system. However, at the higher tonnages, the direct dump stations are

probably better value, because they provide a more flexible operation, and allow waste to be pre-sorted and inspected on the tipping floor.

Section 5.3 Decision Models

This section describes two decision making procedures; transfer haul versus direct haul in collection trucks, and transfer stations as replacements for landfills.

a) Transfer Haul Versus Direct Haul

Section 5.2 and Appendix B describe the cost components associated with transfer haul using some typical examples. The total cost of transfer includes a fixed base cost plus a hauling cost that is a function of haul distance. In general, the transfer cost may be expressed as follows:

$$T = ax + b \quad (1)$$

where : T = total haul cost per tonne,

a = unit haul cost per tonne per kilometre of haul distance,

b = fixed base cost per tonne, and

x = the round trip haul distance in kilometres.

Both a and b will vary with the solid waste quantity to be hauled. [Table 3](#) shows typical values of a and b using the examples detailed in Appendix B.

Table 3. Example Landfill Costs

Waste Quantity (tonnes/year)	Annual Fixed Cost (\$)	Annual Hauling Cost (\$/km)	Per Tonne Fixed Cost "b" (\$/t)	Per Tonne Haul Cost "a" (\$/t-km)
100	178,000	100	178	1.0
1,000	60,000	343	60	0.34

10,000	337,000	1,223	33.7	0.12
--------	---------	-------	------	------

Note: Cost estimates are given in Appendix B, Examples A, F and I.

Direct haul is assumed to be carried out by 5 tonne packer trucks. The direct haul cost includes the recovery of the truck purchase price, wages of the driver and swamper (waste collectors), insurance and licence fees, and other operation and maintenance costs. [Table 4](#) summarizes the unit costs for direct haul, per haul distance (\$/km), for three different crew sizes.

Table 4. Unit Direct Haul Cost per Kilometre

Crew Size	Unit Cost "c" (\$/tonne-kilometre)
Driver only	0.30
Driver plus one swamper	0.40
Driver plus two swampers	0.50

The unit direct haul cost may be generalized as follows:

$$D = cx \quad (2)$$

where D = direct haul cost per tonne

c = unit direct haul cost (Table 4), and

x = round trip haul distance in kilometres.

A nomograph shown in Figures 6 and 7, at the end of this section, can be used to estimate and compare approximate direct and transfer haul costs. Figure 6 shows estimates of "a" and "b" for given annual waste tonnages. Figure 7 illustrates Equation 2 with the "c" values shown in Table 4. The procedure to be followed is:

1. Estimate average annual waste tonnage over the design period, say 5 to 10 years. (Let us assume it is 10,000 tonnes/year).

2. Find the per tonne transfer haul cost per km of haul distance (for 10,000 tonnes/year) from Graph a of Figure 6. (This is \$0.12/tonne-km).
3. Find the fixed base transfer cost per tonne (for 10,000 tonnes/year) from Graph b of Figure 6. (This is \$33/tonne).
4. Use the transfer haul cost data (\$33/tonne and \$0.12/tonne-km) and Equation 1 with the direct haul unit cost data ("c") and Equation 2 to find the break-even points for direct haul as follows:

Crew Size	Round Trip Haul Distance
One person	190 km
Two people	120 km
Three people	84 km

5. Determine the round trip transfer and direct haul distances. (Assume they are both 130 km for this example). At 130 km, the direct haul distance exceeds the break-even point for a two-person crew, and transfer haul should be considered. Alternately, a one-person crew direct haul by a 5 tonne packer truck would be more economical than transfer haul up to a round trip haul distance of 190 km, if the waste disposal requirement is about 10,000 tonnes/year.

For rural areas where collection service costs become excessive, transfer facilities may have to be provided for the convenience of the public.

b) Transfer Versus Landfill

[Table 1](#) in [Section 5.1](#) presents a summary of typical landfilling costs to meet the provincial Landfill Criteria, and Appendix A details the various assumptions for the example cost estimates. Table 5 summarizes the landfill costs in terms of \$/tonne.

Table 5. Example Landfill Unit Costs

Capacity (tonnes/year)	Example Landfill Type	Unit Cost (\$/tonne)
100	A. Natural Attenuation	\$ 828
	B. Engineered Landfill	\$ 1,164
1,000	C. Natural Attenuation	\$ 133
	D. Engineered Landfill	\$ 255

10,000	E. Natural Attenuation	\$	51
	F. Engineered Landfill	\$	81
100,000	G. Natural Attenuation	\$	13
	H. Engineered Landfill	\$	28

Using the cost data shown in Tables [3](#) and [5](#), a simple and easy-to-use nomograph was prepared for assisting in the decision of whether to replace a landfill with a transfer station. This decision making procedure is described below:

1. Estimate the average annual waste tonnage over a design period of say 10 to 20 years, for two landfills. (Let us assume they are a 500 tonne/year natural attenuation site and a 4,000 tonne/year engineered site).
2. Determine the round trip transfer haul distance from the potential transfer station site (the smaller landfill site in this example; assume 160 km), to the waste disposal site (the larger landfill).
3. Find the landfilling costs for using both sites simultaneously, and for using only the larger site to accept transferred waste as well, i.e. 4,500 tonnes/year. (Using Figure 8, the costs are: $\$300/t \times 500t + \$150/t \times 4,000t = \$750,000$ for the two sites; and $\$140/t \times 4,500t = \$630,000$ for a single site).
4. Find the transfer cost from Figure 6. (Using Equation (1), the transfer cost is $\$100/t \times 500t + \$0.48/t\text{-km} \times 500t \times 160 \text{ km} = \$88,400$. The total annual cost for transferring waste from the small landfill to the larger sub-regional site is $\$718,400/\text{yr}$, which is lower than the cost of running two landfills, at $\$750,000/\text{yr}$).

These example decision models should be applied with some reference to local conditions; the user should refer to the underlying cost examples contained in Appendix A and B, and relate the costs to local conditions.

Section 5.4 Financing Transfer Stations

There are a number of ways for local government to finance solid waste management functions including waste transfer via transfer stations. They include general revenue and user fees (uniform fees or sub-area/facility specific fees). Implementation of a true user fee system, which would promote the 3 Rs by users, will require facility staffing during operating hours. A modified user fee system would be a fixed charge per user, regardless of the extent or frequency of use. This could be done, for example, by issuing keys to the transfer station gate to local area users, or by using a card lock system, and charging an annual fee to the users who receive keys or cards.

Local governments should be aware of the Provincial Rural Waste Management Financial Assistance Program. Under this program, a portion of the initial capital cost of transfer stations can be considered for by the province as follows:

1. Up to one third of the initial capital cost, to a maximum of \$30,000, to close an existing inappropriate rural landfill and replace it with a transfer station.
2. Up to one third of the initial capital cost, to a maximum of \$20,000, to install a transfer station at a new site.

Another aspect that should be considered by local government includes establishing a partnership with the private sector. The extent of the partnership could vary from an equipment supply contract to a build/own/operate/transfer (BOOT) contract. Under a BOOT contract, a private contractor would be responsible for construction and operation of the transfer station for a fee.

Guidelines for Establishing Transfer Stations for Municipal Solid Waste

Appendix A. Example Landfill Cost Estimates

EXAMPLE A - 100 TPY NATURAL ATTENUATION LANDFILL

Assumptions

At 100 tonnes/year, the landfill is classified as a modified sanitary landfill in the MoE Landfill Criteria. Leachate generated at the site is assumed to be naturally attenuated, therefore no leachate collection or treatment works are required. Further, gas management and a weigh scale are not required. The trench fill method is assumed. Assuming a 30 year operating life, constant discharge rate during operating life, that cover material constitutes an additional 20% of the waste by weight, and a density of compacted waste of 0.45 tonnes/m³, the total volume required is 8,000 m³. Assuming a fill depth of 6.5 metres, the land area required is approximately 2.1 ha.

Capital Costs

1.	Site Survey and Mapping	\$	3,000
2.	Hydrogeological Monitoring - Two wells @ \$10,000 and \$5,000 for monitoring and interpretation	\$	25,000
3.	Land Acquisition - 2.1 hectares at \$25,000/ha	\$	52,500
4.	Site Preparation - Clearing, grubbing and rough grading of fill area only	\$	600
5.	Access Road - Assume 1.5 km of road, 8 m wide, upgraded by adding 150 mm of crushed gravel; 12,000 m ² @ \$8.00/m ²	\$	96,000
6.	Fencing, Gate and Signs - Around perimeter of site, 577 m @ \$35/m and \$200 for signs	\$	20,400

NOTE: The fencing component of capital costs for all landfill cost estimates in

this appendix does not include provision for electric predator/bear-proof fencing. An additional cost of approximately \$12-\$15 per metre of fenced perimeter should be added to allow for this option.

7. Drainage Control - Assume drainage ditch on two sides of landfill perimeter, 88.5 m of ditch, at \$10/m	\$	900
8. Equipment - Included as operating cost	\$	n/a
9. Equipment Storage Facility - Two-bay building with concrete floor, 100 m ² , at \$600/m ²	\$	60,000
Sub-total	\$	253,400
Contingency Allowance - 10%		25,300
Sub-total	\$	278,700
Engineering - 15%		42,600
TOTAL CAPITAL COST		\$326,800

Capital payback at 8% over ten years: \$48,700/yr

Operating Costs

1. Staffing and Equipment - Compaction and cover: one hour per day, three days a week, bulldozer at \$90/hr: \$14,000/yr Inspection and maintenance: six hours per week, at \$20/hr: \$6,200/yr. Total:	\$	20,200/yr
2. Cover Materials - As in Example A	\$	200/yr
3. Environmental Monitoring Program - For engineered site	\$	4,000/yr

4.	Annual Report	\$ 5,000/yr
5.	Litter Control Fencing - At active face only	\$ 300/yr
6.	Closure Fund - Require 1925 m ² of top liner, final grading, cover, topsoil, and seeding, at \$30/m ² , which is \$58,000 in 1994 dollars. Assume this expenditure will be made 30 years hence, in the year 2024. Assume an annual interest rate of 8%. The annual contribution required to a sinking fund is $0.009 \times \$58,000$, or:	\$ 500/yr
7.	Post Closure Fund - Need to make an annual expenditure for 20 years after closure, i.e. from the year 2024 to 2044. These annual costs, in 1994 dollars, will be about \$5,000/yr, for monitoring and repair of settlement and cover. The present worth of \$5,000/yr over 20 years at 8% interest is $9.818 \times \$5,000$, or \$49,000. The annual contribution in 1994 \$s required to have this lump sum available in 2024, at 8% annual interest, is $0.009 \times \$49,000$, or:	\$ 400/yr
8.	General Site Maintenance - Building, pavement and services	\$ 400/yr
	Sub-total	\$ 31,000/yr
	Administrative Allowance - 10%	3,100/yr
	TOTAL OPERATING COST	\$34,100/yr

TOTAL ANNUAL COST INCLUDING CAPITAL PAYBACK: \$82,800/yr

EXAMPLE B - 100 TPY ENGINEERED LANDFILL

Assumptions

At 100 tonnes/year, the landfill is classified as a modified sanitary landfill in the MoE Landfill Criteria. Trench fill method assumed. As natural attenuation of leachate is not available, engineering measures are necessary for leachate control. No weigh scales or gas control measures are required. The volume and land requirements are as in Example A, i.e. 8,000 m³ and 2.1 ha.

Capital Costs

1.	Site Survey and Mapping	\$ 3,000
2.	Hydrogeological Monitoring - Two wells @ \$10,000 and \$5,000 for monitoring and interpretation	\$ 25,000
3.	Land Acquisition - As in Example A	\$ 52,500
4.	Site Preparation - As in Example A	\$ 600
5.	Access Road - As in Example A	\$ 96,000
6.	Fencing, Gate and Signs - As in Example A	\$ 20,400
7.	Drainage Control - As in Example A	\$ 900
8.	Leachate Management System - Lining, miscellaneous piping, manholes, geotextiles, filter fabric, and drainage rock. 1,925 m ² @ \$30/m ² : \$57,800. Collection piping, 8 - 10 cm diameter, 100 m @ \$100/m: \$10,000. Simple pump station @ \$25,000: \$25,000, and 1,000 m of 75 mm diameter force main @ \$60/m: \$60,000. (NB - The assumption is that leachate can be pumped one km to a safe disposal location, such as a municipal sewage treatment plant). Total cost:	\$ 152,800
9.	Equipment - Included in operating costs	n/a
10.	Equipment Storage Facility - As in Example A:	\$ 60,000
	Sub-total	\$ 411,200

Contingency Allowance - 10%	41,100
-----------------------------	--------

Sub-total	\$ 452,300
-----------	------------

Engineering - 15%	67,800
-------------------	--------

TOTAL CAPITAL COST	\$520,100
---------------------------	------------------

Capital payback at 8% over ten years: \$77,500/yr

Operating Costs

1. Staffing and Equipment - As in Example A	\$ 20,200/yr
---	--------------

2. Cover Materials - Excavated on site, 45 tonnes/yr at \$5/tonne	\$ 200/yr
---	-----------

3. Environmental Monitoring Program - For engineered site	\$ 8,000/yr
---	-------------

4. Annual Report	\$ 5,000/yr
------------------	-------------

5. Litter Control Fencing - As in Example A	\$ 300/yr
---	-----------

6. Closure Fund - As in Example A	\$ 500/yr
-----------------------------------	-----------

7. Post Closure Fund - As in Example A	\$ 400/yr
--	-----------

8. General Site Maintenance - Building, pavement and services including	\$ 800/yr
---	-----------

leachate management system

Sub-total	\$ 35,400/yr
-----------	--------------

Administrative Allowance - 10%	3,500/yr
--------------------------------	----------

TOTAL OPERATING COST	\$38,900/yr
-----------------------------	--------------------

TOTAL ANNUAL COST INCLUDING CAPITAL PAYBACK: \$116,400/yr

EXAMPLE C - 100 TPY NATURAL ATTENUATION LANDFILL

Assumptions

At 1000 tonnes/year, the landfill is classified as a modified sanitary landfill in the MoE Landfill Criteria. Leachate generated at the site is assumed to be naturally attenuated. A leachate management system, gas control system, and weigh scales are not required. The trench fill method is assumed. Assuming a 30 year operating life, constant discharge rate during operating life, additional 20% of waste by weight for cover material, and a density of compacted waste of 0.45 tonnes/m³, the total volume required is 80,000 m³. Assuming a 6.5 metre fill depth, the land area required, including buffer, is 6.4 ha.

Capital Costs

1.	Site Survey and Mapping	\$ 3,000
2.	Hydrogeological Monitoring - Three wells @ \$10,000 and \$5,000 for monitoring and interpretation	\$ 35,000
3.	Land Acquisition - 6.4 hectares at \$25,000/ha	\$ 160,000
4.	Site Preparation - Clearing, grubbing and rough grading of fill area only	\$ 3,600
5.	Access Road - As in Examples A and B	\$ 96,000
6.	Fencing, Gate and Signs - Around perimeter of entire site. 1,152 m @ \$35/m and \$300 for signs: NOTE: No provision for electric predator / bear fencing included. See Example A for cost estimate for this option.	\$ 40,300
7.	Drainage Control Ditch and Culvert - Drainage ditch on two sides of landfill perimeter, 376 m, at \$10/m	\$ 3,800
8.	Equipment - Included in operating costs	\$ n/a

9. Equipment Storage Facility - Two-bay building, concrete floor, 100 m ² , at	\$ 60,000
\$600/m ²	_____
Sub-total	\$ 401,700
Engineering - 15%	40,200

Sub-total	\$ 441,900
Engineering - 15%	66,300

TOTAL CAPITAL COST	\$508,200

Capital payback at 8% over ten years: \$75m700/yr

Operating Costs

- Staffing and Equipment - Compaction and cover, one hour per day, three days a week, bulldozer at \$90/hr: \$14,000/yr. Inspection and maintenance, six hours per week, at \$20/hr: \$6,200/yr. Total: \$34,3200/yr
- Cover Materials - Excavated on site, 445 tonnes/yr at \$5/tonne \$ 2,200/yr
- Environmental Monitoring Program - For natural attenuation site: \$ 4,000/yr
- Annual Report \$ 5,000/yr
- Litter Control Fencing - At active face only \$ 300/yr
- Closure Fund - 16,575 m² at \$30/m² is \$497,300 in 1994 \$, required for final grading, cover, topsoil and seeding. Assume this expenditure will be made 30 years hence, in the year 2024. Assume an annual interest rate of 8%. The annual contribution required to a sinking fund is 0.009 x \$497,300, \$ 4,500/yr

or:

7. Post Closure Fund - Need to make an annual expenditure for 20 years after \$ 900/yr closure, i.e., from the Year 2024 to 2044. These annual costs, in 1994 \$, will be about \$10,000/yr, for monitoring and repair of settlement and cover. The present worth of \$10,000/yr over 20 years at 8% interest is $9.818 \times \$10,000$, or \$98,000. The annual contribution in 1994 \$ required to have this lump sum available in 2024, at 8% annual interest, is $0.009 \times \$98,000$,

or:

8.	General Site Maintenance - Building, pavement and services	\$ 600/yr
	Sub-total	\$ 51,800/yr
	Administrative Allowance - 10%	5,200/yr
	TOTAL OPERATING COST	\$57,000/yr

TOTAL ANNUAL COST INCLUDING CAPITAL PAYBACK: \$132,700/yr

EXAMPLE D - 1,000 TPY ENGINEERED LANDFILL

Assumptions

At 1000 tonnes/year, the landfill is classified as a modified sanitary landfill in the MoE *Landfill Criteria*. A formal system of leachate collection and management is required because natural attenuation is not available. Gas control and a weigh scale are not required. The trench fill method is assumed, giving the same volume and land area requirements as in Example C.

Capital Costs

1.	Site Survey and Mapping	\$	3,000
2.	Hydrogeological Monitoring - Three wells @ \$10,000 and \$5,000 for monitoring and interpretation	\$	35,000
3.	Land Acquisition - As in Example C	\$	160,000
4.	Site Preparation - As in Example C	\$	3,600
5.	Access Road - As in Examples A, B and C	\$	96,000
6.	Fencing, Gate and Signs - As in Example C	\$	40,300
7.	Drainage Control - As in Example C	\$	3,800
8.	Leachate Management System - Lining, miscellaneous piping, manholes, geotextiles, filter fabric and drain rock; 16,575 m ² @ \$30/m ² : \$497,300. Collection piping, 100 mm diameter, 100 m @ \$100/m: \$10,000. Simple pump station @ \$25,000, plus 1,000 m of 75 mm force main @ \$60/m: \$60,000. Total cost:	\$	592,300
9.	Equipment - Included in operating costs	\$	n/a
10.	Equipment Storage Facility - As in Example C:	\$	60,000
	Sub-total	\$	994,000
	Contingency Allowance - 10%		94,400
	Sub-total	\$	1,093,400
	Engineering - 15%		164,000
	TOTAL CAPITAL COST		\$1,257,400

Capital payback at 8% over ten years: \$187m400/yr

Operating Costs

1.	Staffing and Equipment - As in Example C	\$ 34,300/yr
2.	Cover Materials - As in Example C	\$ 2,200/yr
3.	Environmental Monitoring Program - For engineered site	\$ 12,000/yr
4.	Annual Report	\$ 5,000/yr
5.	Litter Control Fencing - As in Example C	\$ 300/yr
6.	Closure Fund - As in Example C	\$ 4,500/yr
7.	Post Closure Fund - As in Example C	\$ 900/yr
8.	General Site Maintenance - Building, pavement and services including leachate management system	\$ 2,100/yr
	Sub-total	\$ 61,300/yr
	Administrative Allowance - 10%	6,100/yr
	TOTAL OPERATING COST	\$67,400/yr

TOTAL ANNUAL COST INCLUDING CAPITAL PAYBACK: \$254,800/yr

EXAMPLE E - 10,000 TPY NATURAL ATTENUATION LANDFILL

Assumptions

At 10,000 tonnes/year, the landfill is classified as a sanitary landfill in the MoE Landfill Criteria. Leachate generated at the site is assumed to be naturally attenuated so no formal collection works are required. Gas collection is not required, however weigh scales are required. The area fill method is assumed. Assuming a 30 year operating life, constant discharge rate during operating life, additional 20% of waste by weight for cover material, and a density of compacted waste of 0.6 tonnes/m³, a total volume of 600,000 m³ is required. Assuming a fill depth of 25 m, the total land area required is 10 ha.

Capital Costs

1.	Site Survey and Mapping	\$	5,000
2.	Hydrogeological Monitoring - Five wells @ \$10,000 and \$10,000 for monitoring and interpretation	\$	60,000
3.	Land Acquisition - 10 hectares, at \$25,000/ha	\$	250,000
4.	Site Preparation - Clearing, grubbing, rough grading of fill area only	\$	3,000
5.	Access Road - Assume 1.5 km of road, 8 m wide, upgraded to asphalt @ \$24/m ²	\$	288,000
6.	Fencing, Gate and Signs - Around perimeter of entire site; 1260 m @ \$35.99/m, and \$300 for signs	\$	44,400
7.	Drainage Control - Drainage ditch on two sides of landfill perimeter, 430 m @ \$10/m	\$	4,300
NOTE: No provision for electric predator/bear fencing included. See Example A for cost estimate for this option.			
8.	Weight Measurement - In/outbound scales and scale house	\$	200,000
9.	Equipment - One bulldozer purchased; other equipment brought in as needed & included under operating cost	\$	200,000

10. Equipment Storage Facility - Three-bay building, concrete floor, 150 m ² , at \$ 90,000 \$600/m ²	
11. Designated Recycling Area - Designated areas for recyclables, \$ 46,600 compostables, reusable materials (bulky/white goods), tires and batteries. 30 m by 30 m by asphalt pad, @ \$24/m ² : plus a storage shed and containers: \$25,000. Total cost:	
12. Site Servicing - Water supply and distribution; assume a water supply well \$ 80,000 \$10,000 plus 100 m of 150 mm pipe @ \$85/m, plus hydrants, valves and appurtenances, for an additional \$10,000. Electrical power and distribution, say 100 m at \$40/m, plus on-site distribution and site lighting, allow \$50,000. Septic tank and tile field, \$10,000. Total site servicing:	
13. Landscaping - Trees, shrubs, bark mulch \$ 10,000	

Sub-total	\$ 1,281,300
Contingency Allowance - 10%	128,100

Sub-total	\$ 1,409,400
Engineering - 15%	211,400

TOTAL CAPITAL COST	\$1,620,800

Capital payback at 8% over ten years: \$241,500/yr

Operating Costs

1. Staffing - Full-time landfill supervisor, \$50,000/yr, scale attendant, \$ 138,300/yr
\$40,000/yr, and a dozer/loader operator, \$40,000/yr. Part time staff or

drop-off area, 4 hours/day, 2 days/week, @ \$20/hr: \$8300/yr. Total staff costs:

2.	Equipment Operation - Bulldozer operation, two hours/day, six days per week, at \$100/hour	\$	62,400/yr
3.	Cover Material - Excavated on site: 3,333 tonnes/yr at \$5/tonne	\$	16,700/yr
4.	Ongoing Clearing, Grubbing and Grading	\$	300/yr
5.	Environmental Monitoring Program - For natural attenuation site	\$	4,000/yr
6.	Annual Report	\$	5,000/yr
7.	Litter Control Fencing - At active face only	\$	300/yr
8.	Closure Fund - 46,225 m ² at \$30/m ² is approximately \$1,386,800 in 1994 \$, required for final grading, cover, topsoil, and seeding. Assume this expenditure will be made 30 years hence, in the year 2024. Assume an annual interest rate of 8%. The annual contribution required to a sinking fund is $0.009 \times \$1,386,800$, or:	\$	12,500/yr
9.	Post Closure Fund - Need to make an annual expenditure for 20 years after closure, i.e., from the Year 2024 to 2044. These annual costs, in 1994 \$, will be about \$20,000/yr, for monitoring and repair of settlement and cover. The present worth of \$20,000/yr over 20 years at 8% interest is $9.818 \times \$5,000$, or \$196,400. The annual contribution in 1994 \$ required to have this lump sum available in 2024, at 8% annual interest, is $0.009 \times \$196,400$, or:	\$	1,800/yr
10.	General Site Maintenance - Building, pavement and services:	\$	2,700/yr
	Sub-total	\$	244,000/yr
	Administrative Allowance - 10%		24,400/yr

TOTAL OPERATING COST

\$268,400/yr

TOTAL ANNUAL COST INCLUDING CAPITAL PAYBACK: \$509,900/yr

EXAMPLE F - 10,000 TPY ENGINEERED LANDFILL

Assumptions

At 10,000 tonnes/year, the landfill is classified as a sanitary landfill in the MoE Landfill Criteria. Leachate control works and weigh scales are required, but gas controls are not. The area fill method is assumed. The volume and land requirements are the same as in Example E.

Capital Costs

1.	Site Survey and Mapping	\$	5,000
2.	Hydrogeological Monitoring - As in Example E	\$	60,000
3.	Land Acquisition - As in Example E	\$	250,000
4.	Site Preparation - As in Example E	\$	3,000
5.	Access Road - As in Example E	\$	288,000
6.	Fencing, Gate and Signs - As in Example E	\$	44,400
7.	Drainage Control - As in Example E	\$	4,300
8.	Leachate Management System - Lining, miscellaneous piping, manholes, geotextiles, filter fabrics, and drain rock; 46,225 m ² @ \$30/m ² : \$1,386,800. Collection piping, 100 mm diameter, 430m @ \$100/m:	\$	1,514,800

\$43,000. Simple pump station (\$25,000), plus 1,000m of 75 mm pipe @

\$60/m: \$60,000. Total cost:

9.	Weight Measurement - As in Example E	\$	200,000
10.	Equipment - As in Example E	\$	200,000
11.	Equipment Storage Facility - As in Example E	\$	90,000
12.	Designated Recycling Area - As in Example E	\$	46,600
13.	Site Servicing - As in Example E	\$	80,000
14.	Landscaping - As in Example E	\$	10,000

	Sub-total	\$	2,796,100
	Contingency Allowance - 10%		279,600

	Sub-total	\$	3,075,700
	Engineering - 15%		461,400

	TOTAL CAPITAL COST		\$3,537,100

Capital payback at 8% over ten years: \$527,000/yr

Operating Costs

1.	Staffing and Equipment - As in Example E	\$	138,300/yr
2.	Equipment Operation - As in Example E	\$	62,400/yr
3.	Cover Material - As in Example E	\$	16,700/yr
4.	Ongoing Clearing, Grubbing and Grading - As in Example E	\$	300/yr
5.	Environmental Monitoring Program - For engineered site	\$	12,000/yr

6.	Annual Report	\$	5,000/yr
7.	Litter Control Fencing - As in Example E	\$	300/yr
8.	Closure Fund - As in Example E	\$	12,500/yr
9.	Post Closure Fund - As in Example E	\$	1,800/yr
10.	General Site Maintenance - Building, pavement and services, including leachate management system	\$	6,500/yr
	Sub-total	\$	255,800/yr
	Administrative Allowance - 10%		25,600/yr
	TOTAL OPERATING COST		\$281,400/yr

TOTAL ANNUAL COST INCLUDING CAPITAL PAYBACK: \$808,400/yr

EXAMPLE G - 10,000 TPY NATURAL ATTENUATION LANDFILL

Assumptions

At 100,000 tonne/year, the landfill is classified as a sanitary landfill in the MoE Landfill Criteria. Leachate generated at the site is assumed to be naturally attenuated; therefore leachate control works are not required. Weigh scales are required, and a gas extraction and flaring system is required. The area fill method is assumed. Assuming a 30 year operating life, constant discharge rate during operating life, additional 20% of waste by weight for cover material, and an in place waste density 0.6 tonnes/m³, the total volume required is 6,000,000 m³. Assuming a fill depth of 35 m, the total site area required is 37 ha, including the stipulated buffer zone.

Capital Costs

1.	Site Survey and Mapping	\$	5,000
2.	Hydrogeological Monitoring - Five wells @ \$10,000 and \$10,000 for monitoring and interpretation	\$	60,000
3.	Land Acquisition - 37 hectares, at \$25,000/ha	\$	925,000
4.	Site Preparation - Clearing, grubbing and rough grading of fill area only	\$	3,000
5.	Access Road - As in Examples E and F	\$	288,000
6.	Fencing, Gate and Signs - Around perimeter of entire site, 2440 m @ \$35/m and \$300 for signs: NOTE: No provision for electric predator/bear-fencing included. See Example A for cost estimate for this option.	\$	85,700
7.	Drainage Control - Drainage ditch on two sides of landfill perimeter, 1,020 m of ditch at \$10/m	\$	10,200
8.	Landfill Gas Management System - This site will generate NMOCs in excess of 150 tonnes/yr, and will need a gas management system. Assume 70 extraction wells @ \$5,000; \$350,000, a flare station at \$300,000, and monitoring probes @ \$10,000. Total cost:	\$	660,000
9.	Weight Measurement - In/outbound scales and scale house:	\$	200,000
10.	Equipment - One steel wheeled compactor @ \$400,000, and one bulldozer or tracked loader @ \$200,000:	\$	600,000
11.	Equipment Storage Facility - Three-bay building with concrete floor, 150 m ² , at \$600/m ² :	\$	90,000
12.	Designated Recyclables Area - Designated area for recyclables, compostables, reusable materials (bulky/white goods), tires, and batteries. 30 m by 30 m by asphalt pad, @ \$24/m ² : \$21,600 Storage shed, including containers: \$25,000. Total cost:	\$	46,600
13.	Site Servicing - Water supply and distribution, assume a supply well, plus	\$	170,000

1,000 m of 150 mm pipe, at \$85/m, plus hydrants, valves, and appurtenances, for a total of \$110,000. Electrical power and distribution, say 100m at \$40/m, plus on-site tile field, \$10,000. Total site servicing:

14.	Landscaping - Trees, shrubs, bark mulch:	\$ 10,000

	Sub-total	\$ 3,153,500
	Contingency Allowance - 10%	315,400

	Sub-total	\$ 3,468,900
	Engineering - 15%	520,300

	TOTAL CAPITAL COST	\$3,989,200

Capital payback at 8% over ten years: \$594,400/yr

Operating Costs

- Staffing - Full-time landfill supervisor, \$50,000/yr, one scale attendant, \$40,000/yr, two dozer/loader operators, \$80,000/yr and one half-time employee for the drop-off area, \$20,00/yr. Total: \$ 190,000/yr
- Equipment Operation - Compactor operation, two hours/day, six days per week, at \$150/hour: \$93,600/yr. Bulldozer operation, two hours per day, six days/week, at \$100/hour: \$62,400/yr. Total: \$ 156,000/yr
- Cover Material - Excavated on site, 33,333 tonnes/yr at \$5/tonne \$ 167,000/yr
- Ongoing Clearing, Grubbing and Excavating \$ 600/yr
- Environmental Monitoring Program - For a natural attenuation site \$ 4,000/yr

6.	Annual Report	\$ 5,000/yr
7.	Litter Control Fencing - At active face only	\$ 300/yr
8.	Closure Fund - 260,100 m ² at \$30/m ² is approximately \$7,803,000 in 1994 \$, required for final grading, cover, topsoil, and seeding. Assume this expenditure will be made 30 years hence, in the Year 2024. Assume an annual interest rate of 8%. The annual contribution required to a sinking fund is $0.009 \times \$7,803,000$ or:	\$ 70,200/yr
9.	Post Closure Fund - Need to make an annual expenditure for 20 years after closure, i.e., from the Year 2024 to 2044. These annual costs, in 1994 \$, will be about \$50,000/yr, for monitoring and repair of settlement and cover. The present worth of \$50,000/yr over 20 years at 8% interest is $9.818 \times \$5,000$, or \$490,900. The annual contribution in 1994 \$ required to have this lump sum available in 2024, at 8% annual interest, is $0.009 \times \$490,900$, or:	\$ 4,400/yr
10.	General Site Maintenance - Building, pavement and services	\$ 5,500/yr
	Sub-total	\$ 603,000/yr
	Administrative Allowance - 10%	60,300/yr
	TOTAL OPERATING COST	\$663,300/yr

TOTAL ANNUAL COST INCLUDING CAPITAL PAYBACK: \$1,257,700/yr

EXAMPLE H - 100,000 TPY ENGINEERED LANDFILL

Assumptions

At 100,000 tonnes/year, the landfill is classified as a sanitary landfill in the MoE Landfill Criteria. Because there is no natural attenuation of leachate, engineered leachate control works are required. Gas extraction wells and a flare, and weigh scales are also required. The area fill method is assumed. The total volume and land area required are as in Example G.

Capital Costs

1.	Site Survey and Mapping	\$	5,000
2.	Hydrogeological Monitoring - As in Example G	\$	60,000
3.	Land Acquisition - As in Example G	\$	925,000
4.	Site Preparation - As in Example G	\$	3,000
5.	Access Road - As in Examples E, F and G	\$	288,000
6.	Fencing, Gate and Signs - As in Example G	\$	85,700
7.	Drainage Control - As in Example G	\$	10,200
8.	Leachate Management System - Lining, miscellaneous piping, manholes, geotextiles, filter fabrics, and drain rock; 260,100 m ² @ \$30/m ² : \$7,803,000. Collection piping, 100 mm diameter, 1,020m @ \$100/m: \$102,000. Simple pump station, \$25,000, plus 1,000 m of 75mm force main @ \$60/m: \$60,000. Total cost:	\$	7,990,000
9.	Landfill Gas Management System - As in Example G	\$	660,000
10.	Weight Measurement - As in Example G	\$	200,000
11.	Equipment - As in Example G	\$	600,000
12.	Equipment Storage Facility - As in Example G	\$	90,000
13.	Designated Recycling Area - As in Example G	\$	46,600

14.	Site Servicing - As in Example G	\$ 170,000
15.	Landscaping - As in Example G	\$ 10,000
		<hr/>
	Sub-total	\$ 11,143,500
	Contingency Allowance - 10%	1,114,400
		<hr/>
	Sub-total	\$ 12,257,900
	Engineering - 15%	1,838,700
		<hr/>
	TOTAL CAPITAL COST	\$14,096,600

Capital payback at 8% over ten years: \$2,200,400/yr

Operating Costs

1.	Staffing and Equipment - As in Example G	\$ 190,000/yr
2.	Equipment Operation - As in Example G	\$ 156,000/yr
3.	Cover Material - As in Example G	\$ 167,000/yr
4.	Ongoing Clearing, Grubbing and Grading - As in Example G	\$ 600/yr
5.	Environmental Monitoring Program - For engineered site	\$ 12,000/yr
6.	Annual Report	\$ 5,000/yr
7.	Litter Control Fencing - As in Example G	\$ 300/yr
8.	Closure Fund - As in Example G	\$ 70,200/yr
9.	Post Closure Fund - As in Example G	\$ 4,400/yr
10.	General Site Maintenance - Building, pavement and services, including leachate management system	\$ 25,500/yr

Sub-total	\$ 631,000/yr
Administrative Allowance - 10%	63,100/yr
	<hr/>
TOTAL OPERATING COST	\$ 694,100/yr

TOTAL ANNUAL COST INCLUDING CAPITAL PAYBACK: \$2,792,600/yr

Guidelines for Establishing Transfer Stations for Municipal Solid Waste

Appendix B. Example Transfer Station Cost Estimates

EXAMPLE A - 100 TPY ROLLOFF STATION

Capital Costs

1. Land Purchase - Approximately 0.32 hectares, at \$25,000/ha \$ 8,000

2. Site Preparation - Clearing, grubbing, grading (typical) \$ 5,000

3. Access Road and Ramp - Area of 30 m x 15 m, 150 mm of crush @\$3,600 \$ 3,600
\$8.00/m²

4. Retaining Wall - Choices are reinforced concrete, concrete lock blocks, Armco binwall, (wood, e.g. railway ties not recommended) \$ 7,000
 - a) Reinforced Concrete - Need room for two bins, wall x-section approximately 0.9 m³, length approximately 14.5 m. 14.5 m x 0.9 m³/m x \$1,000/m³ = \$13,000
 - b) Lock blocks - The blocks are 750 x 750 x 1500 mm. Cost varies around the province, from \$70 to \$105/block. Each block weighs about 4,400 lb. Freight is typically \$15 -\$30/block. Installation could cost about \$150/hr, assuming a crane and two men could install approximately five blocks/hour = \$30/block. Total \$115 - \$165/block TNRD uses \$140 to \$160/block for their estimates. Assume \$160/block Wall would be 4 blocks high by 11 blocks long = 44 @ \$160 = \$7,040
 - c) Armco Binwall - Require five sections of bolted galvanised steel bin Cost

approximately \$8,000 to purchase, and approximately \$8,000 to install =
\$16,000

Lock blocks appear to be the most economical

5. Concrete Pad - Full length of the wall, 17 m, and 1.5 x the bin width of approximately 2.2 m = 3.3 m. 150 mm thick. Area approximately 56 m² @ \$100/m² \$ 5,600

6. Rolloff Bins - Two at \$5,500 each \$ 11,000

7. Rolloff Bin Cover (or Lids) - Lids cost approximately \$4,000 each (\$8,000), but \$ 10,200 are not suitable in areas of heavy snow unless staff are present to brush off lid.

Also more awkward for people to use. A better solution is a complete sheet metal structure over the bin and chain link around bin sides.

Manufacturer: Northside Steel Fabricators in Kelowna. A structural steel cover for one 38 m³ bin would be 7.9 m long, 3.5 m wide, and 2.4 m high, and would cost \$10,090, including a guide island for the bin. Predator barrier costs \$4,416 for metal cladding and \$1,875 for mesh. Field erection requires bolting, and use of a crane. Time in field - two days/crane plus two men.

Cost: Purchase of cover unit, with mesh and guide \$ 11,965

PST \$ 838

GST	\$ 838
Freight	\$ 600
Crane @ \$100/hr for two days	\$ 1,600
Two men @ \$25/hr for two days	\$ 400

TOTAL	\$ 16,000

8. Fencing, Gate and Signs - Fencing: 4 x 60 m x \$35.00/m = \$8,400 plus a sign \$ 8,600
at \$200

NOTE: The fencing component of capital costs for all landfill cost estimates in this appendix does not include provision for electric predator/bear-proof fencing. An additional cost of approximately \$12-\$15 per metre of fenced perimeter should be added to allow for this option

Sub-total	\$ 64,800
Contingency Allowance - 10%	6,500

Sub-total	\$ 71,300
Engineering - 15%	3,600

TOTAL CAPITAL COST	\$ 74,900

Capital payback at 8% over ten years: \$11,200/yr

Note: Temporary staffing for six to twelve months to train the public could be added to Capital Costs.

Operating Costs

1.	Transfer Station Bin Maintenance and Painting	\$ 1,000/yr
	Site maintenance, cleanup, snow removal. Two hours once per week @ \$20/hr, plus once per year, four hours @ \$65/hr for a loader to re-grade and spread fresh gravel	\$ 2,400/yr
2.	Waste Haulage Rolloff truck @ \$100/hr. Round trip to landfill = x km; travel rate average of 50 km/hr; allow 10 min. turnaround at each end. Assume one trip per week. Annual Unit Waste Haulage Cost = $100x + 1667$ (travel cost plus turnaround cost in \$ per round trip km). Assuming the round trip is 100 km, the total annual cost is:	\$ 11,700/yr
	Sub-total	\$ 15,100/yr
	Administrative Allowance - 10%	1,500/yr
	TOTAL OPERATING COST	<hr style="width: 100%; border: 0; border-top: 1px solid black; margin-bottom: 5px;"/> \$ 16,600/yr
	TOTAL ANNUAL COST INCLUDING CAPITAL PAYBACK: \$27,800/yr	

EXAMPLE B - 100 TPY GREEN BOX STATION

Capital Costs

1.	Land Purchase - As in Example A	\$ 8,000
2.	Site Preparation - As in Example A	\$ 5,000
3.	Access Road - Say 40 m x 8 m, 150 mm of crushed gravel @ \$8.00/m ² (Asphalt option would be approximately \$16.00/m ² extra)	\$ 2,600
4.	Pad Area - Gravelled pad approximately 20 m x 10 m @\$8.00/m ²	\$ 1,600
5.	Bins - Need five 6 cu yd bins (4.6 m ³), assuming pick-up once/week. Five @ \$1,000/bin	\$ 5,000
6.	Fencing, Gate and Signs - As in Example A	\$ 8,600
	Sub-total	\$ 30,800
	Contingency Allowance - 10%	3,100
	Sub-total	\$ 33,900
	Engineering - 15%	1,700
	TOTAL CAPITAL COST	\$ 35,600

Capital payback at 8% over ten years: \$5,300/yr

Operating Costs

1.	Transfer Station	\$ 2,000/yr
	Bin Maintenance and Painting, plus an allowance to replace one bin per year:	

	Site maintenance and cleanup, snow removal, as in Example A:	\$ 2,400/yr
2.	Waste Haulage	\$ 16,300/yr
	Top loading commercial packer at \$135/hr. Assume round trip to landfill = x _____ km, speed 50 km/hr, turnaround time at transfer station 15 min, 10 min at landfill, one trip per week. Following Example A, Annual Unit Waste Haulage Cost = 135x + 2,812. As in Example A, assume x = 100 km. Total annual cost:	
	Sub-total	\$ 20,700/yr
	Administrative Allowance - 10%	2,100/yr

	TOTAL OPERATING COST	\$22,800/yr
	TOTAL ANNUAL COST INCLUDING CAPITAL PAYBACK: \$28,100/yr	

EXAMPLE C - 100 TPY STATION

USING HYDRAULICALLY TIPPABLE CONTAINERS

Capital Costs

1.	Land Purchase - As in Examples A and B	\$ 8,000
2.	Site Preparation - As in Examples A and B	\$ 5,000
3.	Access Road - As in Example B	\$ 2,600

4.	Gravelled Pad Area - As in Example B	\$ 1,600
5.	Bins - Haul-all Hyd-a-way tippable bins, that work off the truck hydraulic system via a quick-connect hose. Bins are 4 cu yd (3 m ³). Would need four bins, if emptied twice per week. Cost installed is approximately \$3,500/bin. An appropriate Haul-All truck would need to be available.	\$ 14,000
6.	Fencing, Gate and Signs - As in Examples A and B	\$ 8,600
	Sub-total	\$ 39,200
	Contingency Allowance - 10%	3,900

	Sub-total	\$ 43,100
	Engineering - 15%	1,100

	TOTAL CAPITAL COST	\$ 45,300

Capital payback at 8% over ten years: \$5,300/yr

Operating Costs

1.	Transfer Station	\$ 2,000/yr
	Bin Maintenance and Painting	
	Site maintenance and cleanup	\$ 2,400/yr
2.	Waste Haulage	\$ 21,800/yr

Haul all truck, 12 - 18 cu yd, @ \$90/hr. Round trip x km, 50 (100/year). _____

Following the previous examples, Annual unit waste haulage cost = 180 x + 3750. Assuming x = 100 km, the total annual cost is:

Sub-total	\$ 26,200/yr
Administrative Allowance - 10%	2,600/yr

\$28,800/yr

TOTAL OPERATING COST
TOTAL ANNUAL COST INCLUDING CAPITAL PAYBACK: \$35,600/yr

EXAMPLE D - 100 TPY, DEDICATED TRUCK

A packer truck, parked at a shopping centre, school yard, or cross-roads would receive waste on a specified day for a specified number of hours. No site development or capital costs are incurred.

Operating Cost

One day per week, eight hours a day, including travel time; 8 x 52 x \$ 37,400/yr
 \$90/hr:

Administrative Allowance - 10% 3,700/yr

\$ 41,400/yr

TOTAL OPERATING COST

EXAMPLE E - 1,000 TPY ROLLOFF STATION

Assumptions

1000 tonnes/year divided by 52 weeks/yr = 19.2 tonnes/week. Assuming a peaking factor of 2x, gives a peak quantity of approximately 38 tonnes/week. At 150 kg/m³, the volume would be approximately 253 m³/week. The average daily quantity, based on a five day week, would be about 26m³. There would be a need to haul up to seven 38 m³ bins per week. The facility would have three bays, holding three 38 m³ bins, at the base of a zigzag concrete lock block wall.

1. Land Purchase - Site dimensions would be approximately 70 m x 60 m, or \$ 10,500
0.42 ha, @ \$25,000/ha:

 2. Site Preparation - Clearing, grubbing, grading \$ 6,000

 3. Access Road and Ramp - Road 15 m x 8 m, and ramp 20 x 20 m, for a total \$ 2,600
area of 520m². Gravel 150 mm deep @ \$8.00/m², is \$4,200. Asphalt paving is
recommended, though not essential, to \$8,300.

 4. Retaining Wall - Require approximately 38 lineal metres of wall, 26 blocks long \$ 16,600
by 4 blocks high. Therefore require 104 blocks @ \$160 per block:

 5. Concrete Pad - The total pad area for three bins is estimated at approximately \$ 9,500
95 m², @ \$100/m²:

 6. Rolloff Bins - Require four 50 cu yd (38 m³) bins, at \$5,500 each \$ 22,000

 7. Rolloff Bin Covers - Three steel covers with rollup doors and animal resistant \$ 48,000
mesh screen, each @ \$16,000:

 8. Fencing, Gate and Sign - 260 m of fencing/gate @ \$35.00/m, plus sign: \$ 9,400
- NOTE: No provision for electric predator/bear-fencing included. See Example A
for cost estimate for this option.
- | | |
|-----------------------------|------------|
| Sub-total | \$ 134,500 |
| Contingency Allowance - 10% | 13,500 |

Sub-total	\$ 148,000
Engineering - 15%	14,800

TOTAL CAPITAL COST **\$162,800**

Capital payback at 8% over ten years: \$24,300/yr

Operating Costs

1.	Transfer Station	\$ 2,000/yr
	Bin Maintenance and Painting	

Staffing - Allow 16 hours/week, (either two days open per week with full time staff, or part time about three hours per day, five days a week) at \$20/hr:

Site maintenance, snow removal:	\$ 2,400/yr
---------------------------------	-------------

2.	Waste Haulage	\$ 52,000/yr
----	---------------	--------------

Assume four bins are hauled per week, thus requiring 208 trips per year.

Assume a speed of 50 kph, a turnaround time of 15 min at each end, and a cost of \$100/hr for a rolloff truck. If the round trip haul distance is x km, the annual unit waste haulage cost = $416x + 10,400$. For x = 100 km, the

total annual cost is:

Sub-total	\$ 73,000/yr
Administrative Allowance - 10%	7,300/yr

TOTAL OPERATING COST

\$ 80,300/yr

TOTAL ANNUAL COST INCLUDING CAPITAL PAYBACK: \$104,600/yr

EXAMPLE F - 1,000 TPY STATION

HYDRAULICALLY TIPPABLE (TRANSTOR) BINS

Assumptions

As for Example E, the average daily quantity is about 26 m³. The station would employ two 31 m³ Transtor bins. Assume the tractor and transfer trailer are not purchased, but are covered under the operating costs.

Capital Costs

1.	Land Purchase - As in Example E	\$ 10,500
2.	Site Preparation - As in Example E	\$ 6,000
3.	Access Road and Ramp - As in Example E	\$ 12,500
4.	Retaining Wall - As in Example E	\$ 16,600
5.	Bins - Two Transtor bins, at \$30,000 each, plus a \$1,000 per bin allowance for freight, and a \$2,000 per bin allowance for field assembly	\$ 66,000
6.	Fencing, Gate and Signs - As in Example E	\$ 9,400

Sub-total	\$ 121,000
Contingency Allowance - 10%	12,100

Sub-total	\$ 133,100
Engineering - 15%	13,300

TOTAL CAPITAL COST \$146,400

Capital payback at 8% over ten years: \$21,800/yr

Operating Costs

1. Transfer Station \$ 4,000/yr

Bin Maintenance, including hydraulic systems and bin painting:

Staffing - As in Example E \$ 16,600/yr

Site maintenance, snow removal - as in Example E \$ 2,400/yr

2. Waste Haulage \$ 42,900/yr

26 m³/day average - assume three trips per week, or 156 trips per year. _____

Assume 50 km/hr, 30 minute total turnaround time, and a cost of \$110/hr for the transfer tractor and trailer. For a round trip haul of x km, the annual

unit waste haulage cost would be $343x + 8,580$. For $x = 100$ km, total

annual cost is

Sub-total \$ 65,900/yr

Administrative Allowance - 10% 6,600/yr

TOTAL OPERATING COST

\$72,500/yr

TOTAL ANNUAL COST INCLUDING CAPITAL PAYBACK: \$94,300/yr

EXAMPLE G - 10,000 TPY STATION-DIRECT DUMP

Assumptions

10,000 tonnes/year divided by 52 weeks/yr = 192.3 tonnes/week, or 38.5 tonnes/day, for a five day week. Assuming a density of 150 kg/m³ gives a daily average of approximately 256 m³. The facility would be very similar to the one designed by UMA Engineering for the Regional District of Nanaimo, located in Parksville. This facility has weigh scales with a separate office, and a bi-level steel building on a concrete foundation. Waste is dumped on a concrete floor inside the building, and pushed with an articulated loader into one of two transfer trailers sitting on the lower level. Cost estimates are based largely on this station.

Capital Costs

1. Land Purchase - Site area of approximately 2.5 hectares, to allow for future \$ 62,500 expansion, @ \$25,000/ha:

2. Site Preparation - Clearing, grubbing, grading \$ 10,000

3. Access Road - On-site roads and pad, approximately 400 m, average 10 m \$ 96,000 wide, for a total area of about 4,000m². Gravel plus asphalt, @ \$24.00/m², is

4. Transfer Building - Building area approximately 1,000 m², unit cost \$ 800,000 \$800/m², including concrete bi-level foundation and metal prefabricated

building, with two trailer bays:

5. Weigh Scales and Office - Supply and installation of inbound and outbound scales and scale house: \$ 200,000

6. Site Servicing - Water supply and distribution, assume 1,000 m of 150 mm pipe, at \$85/m, plus hydrants, valves, and appurtenances, for a total of \$100,000. Electrical power and distribution, say 100 m @ \$40/m, plus on-site distribution to scale house and transfer building, and site lighting, allow \$50,000. Septic tank and tile field, \$10,000. Holding tanks and pumps for washdown water (release to tile field if quality acceptable), allow \$10,000.

Total site servicing:

7. Articulated Loader - For use in pushing waste into trailers: \$ 40,000

8. Landscaping - Trees, shrubs, bark mulch: \$ 10,000

9. Fencing, Gate and Sign - 630 m of fencing / gate @ \$35.00/m, plus sign: \$ 22,400

NOTE: No provision for electric predator / bear-fencing included. See Example A for cost estimate for this option.

Sub-total	\$ 1,410,900
Contingency Allowance - 10%	141,000

Sub-total	\$ 1,552,000
Engineering - 15%	232,800

TOTAL CAPITAL COST \$1,784,800

Capital payback at 8% over ten years: \$265,900/yr

Operating Costs

1.	Transfer Station	\$ 3,000/yr
	Maintenance of building, scales, pavement and services, at 0.25% of capital cost:	
	Staffing - Two full-time employees, one on the scales, and one on the tipping floor/loader:	\$ 80,000/yr
	Loader maintenance and operation, 1 hr/day, 5 days/week, at \$40/hr	\$ 10,400/yr
2.	Waste Haulage	\$ 139,000/yr
	Assume eighteen tonnes per trip, in a 90 m ³ trailer (assumed density is 200 kg/m ³ , based on some haulage in packer trucks). Require 556 trips per year. Assume a speed of 50 kph, a turnaround time of 15 min at each end, and a cost of \$100/hr for a transfer truck and trailer. If the round trip haul distance is x km, the annual unit waste haulage cost = 1,112x + 27,800. For x = 100 km, the total annual cost is:	
	Sub-total	\$ 233,400/yr
	Administrative Allowance - 10%	23,300/yr
	TOTAL OPERATING COST	\$256,700/yr
	TOTAL ANNUAL COST INCLUDING CAPITAL PAYBACK: \$522,600/yr	

EXAMPLE H - 10,000 TPY STATION

COMPACTION ROLLOFF BINS

Assumptions

As for Example G, need to handle an average of 256 m³/day, based on a five day week. Assume two-thirds of the daily volume goes to compactor bins, and one-third (bulky and other wastes unsuitable for compaction) to open rolloff bins. The compactor bins would receive about 171 m³/day, and would compact it about 3:1 to 57 m³/day. The open bins would receive about 85 m³/day. The facility would install three 38 m³ bins of each type, for a total of six, at the base of a zigzag concrete lock block wall.

Capital Costs

1.	Land Purchase - As in Example G	\$ 62,500
2.	Site Preparation - As in Example G	\$ 10,000
3.	Access Road and Ramp - As in Example G	\$ 96,000
4.	Retaining Wall - Require approximately 66 lineal metres of wall, 44 blocks long by 4 blocks high. Therefore require 176 blocks @ \$160 per block:	\$ 28,200
5.	Concrete Pad - The total pad area for the six bins is estimated at approximately 200 m ² , @ \$100/m ² :	\$ 20,000
6.	Rolloff bins - 50 cu yd (38 m ³) bins; three compactor bins, at \$24,000 each, and three open bins at \$5,500 each:	\$ 88,500
7.	Rolloff Bin Covers - Three steel covers with rollup doors and animal resistant mesh screen, for the open bins only, each @ \$16,000:	\$ 48,000
8.	Weigh Scales and Office - As in Example G	\$ 200,000
9.	Site Servicing - As in Example G	\$ 170,000

10.	Landscaping - As in Example G	\$ 10,000
11.	Fencing, Gate and Signs - As in Example G	\$ 22,400
		<hr/>
	Sub-total	\$ 755,600
	Contingency Allowance - 10%	75,600
		<hr/>
	Sub-total	\$ 831,200
	Engineering - 15%	124,700
		<hr/>
	TOTAL CAPITAL COST	\$955,900

Capital payback at 8% over ten years: \$142,400/yr

Operating Costs

1.	Transfer Station	\$ 6,000/yr
	Bin maintenance, including hydraulics, and painting:	
	Site maintenance, including weigh scales, pavement and services:	\$ 30,000/yr
	Staffing - As in Example G	\$ 80,000/yr
	Power, lighting, miscellaneous:	\$ 1,000/yr

2. Waste Haulage \$ 270,500/yr

The legal payload in a rolloff bin, either a compactor bin or an open bin, is approximately 8 tonnes. Assuming the containers are hauled 80% full, 1,563 bins would have to be hauled per year. If two bins were hauled at once, i.e. by a truck/pup, there would need to be 782 trips per year. Assume a speed of 50 kph, a turnaround time of 45 min at the transfer station, and 30 min at the landfill, and a cost of \$110/hr for a rolloff truck and pup. If the round trip haul distance is x km, the annual unit waste haulage cost = $1,720x + 107,500$. For x = 100 km, the total annual cost is:

Sub-total	\$ 369,500/yr
Administrative Allowance - 10%	37,000/yr

TOTAL OPERATING COST \$406,500/yr

TOTAL ANNUAL COST INCLUDING CAPITAL PAYBACK: \$548,900/yr

EXAMPLE I - 10,000 TPY

HYDRAULICALLY TIPPABLE (TRANSTOR) BINS

Assumptions

As for Examples G and H, the average daily quantity is about 256 m³. If sufficient storage capacity is to be provided for one day, the station would require nine 31 m³ Transtor bins. Assume the tractor and transfer trailer are not purchased, but are covered under the operating costs.

Capital Costs

1.	Land Purchase - As in Examples G and H	\$	62,500
2.	Site Preparation - As in Examples G and H	\$	10,000
3.	Access Road and Ramp - As in Examples G and H	\$	96,000
4.	Retaining Wall - Approximately 50 lineal metres, i.e. 34 lock blocks long by \$ 5 high. 170 blocks @ \$160/block:	\$	27,200
5.	Bins - Nine Transtor bins, at \$30,000 each, plus a \$1,000 per bin allowance\$ for freight, and a \$2,000 per bin allowance for field assembly:	\$	297,000
8.	Weigh Scales and Office - As in Examples G and H	\$	200,000
9.	Site Servicing - As in Examples G and H	\$	170,000
10.	Landscaping - As in Examples G and H	\$	10,000
11.	Fencing, Gate and Signs - As in Examples G and H	\$	22,400
	Sub-total	\$	895,100
	Contingency Allowance - 10%		89,500
	Sub-total	\$	984,600
	Engineering - 15%		147,700
	TOTAL CAPITAL COST		\$1,132,300

Capital payback at 8% over ten years: \$168,700/yr

Operating Costs

TOTAL ANNUAL COST INCLUDING CAPITAL PAYBACK: \$459,300/yr

1.	Transfer Station	\$ 12,000/yr
	Bin maintenance, including hydraulics, and painting:	
	Site maintenance - As in Example H:	\$ 3,000/yr
	Staffing - As in Examples G and H:	\$ 80,000/yr
	Power, lighting, miscellaneous:	\$ 1,000/yr
2.	Waste Haulage	\$ 168,200/yr
	256 m ³ /day average - assume an 18 tonne average load in a transfer trailer, requiring 556 trips per year. Similar to Example G, but the turnaround time at the transfer station is higher, because of the time required to empty three bins into the trailer. Assume 50 km/hr, 30 min at the station and 15 min at the landfill, and a cost of \$110/hr for the transfer tractor and trailer. For a round trip haul of x km, the annual unit waste haulage cost would be $1,223x + 45,900$. For x = 100km, the total annual cost would be:	_____
	Sub-total	\$ 264,200/yr
	Administrative Allowance - 10%	26,400/yr

	TOTAL OPERATING COST	\$290,600/yr

Guidelines for Establishing Transfer Stations for Municipal Solid Waste

Appendix C. Transfer Station Issues

The following discussion of transfer station issues is based on telephone conversations with regional representatives of B.C. Environment who are responsible for solid waste management. The intent of the conversations was to develop an understanding of what issues were seen to be important throughout B.C. The types of problems and issues that have had to be dealt with in Alberta are also summarized in this section, with the solutions found workable in Alberta indicated.

a) Regulations

Unlike landfills and other solid waste disposal facilities, discharge permits are not required for transfer stations. In general, the need for implementing regulations directed at transfer stations is viewed to be unnecessary if they are properly designed and operated to effectively manage the typical problems associated with their use. The role of the provincial government in this area was questioned, as the responsibility for solid waste management essentially rests with the regional districts. It is hoped that parallel legislation and regulations will effectively manage industrial waste streams, hazardous waste, and liquid waste. As part of a municipal solid waste system, transfer stations should not be allowed to accept such materials. However, a contingency plan is still needed for instances when a user discharges such undesirable materials.

b) The Need for Transfer Stations

Opinions on the need for transfer stations varied. Some supported a regional approach to solid waste management that favoured the use of well-planned transfer stations. On the other hand, there were fears that, if poorly operated, a small transfer station may pose an environmental threat similar to a small landfill in some respects, namely problems with litter and wildlife.

c) Facility Design and Operations

It was noted by a number of regional representatives that if a transfer station is properly designed and managed, the problems commonly associated with them should not arise. Design should focus on the needs of the particular host community, and on local conditions. Consider the need for compaction and weigh scales, the existence of freezing conditions, traffic flow, and wildlife. Designers and planners should take advantage of the variety of equipment available. It is necessary to identify the elements that constitute an environmentally responsible transfer station. Maintenance and operation must ensure that a station is properly managed with respect to the environment. Cost estimates are important during the review of alternative solutions.

d) Siting

It appears that the trend to site transfer stations in low profile areas is slowly reversing itself, as solid waste managers site transfer stations in more visible locations. Placing a station near a frequently visited facility, such as a store or community centre, will reduce the need for a full-time attendant. A high volume of visitors to the area tends to encourage a tidy and well-used facility.

e) Staffing

Staff at a transfer station allows the implementation of separation and reduction initiatives, the keeping of a tidy site, the charging of tipping fees, the use of a weigh scale, and fosters good public relations. The disadvantage of staffing a facility is the cost. However, at unstaffed facilities, there is the potential for illicit dumping, and tipping fees cannot be charged. Coin operated gates have been considered in the interior, but they do not address the problem of dumping of undesirable wastes, nor do they allow for payment on the basis of volume dumped. Another suggestion was to begin by staffing a transfer station, but phase it out as the public becomes accustomed to the facility. The size of the facility, the location, and the service population are all influencing factors. In small communities, the tight-knit attitude of the population can ensure proper use and tidiness instead of an attendant.

f) Difficult Wastes

The regional MELP representatives had mixed views on the management of bulky wastes such as furniture and appliances, although it was thought to be an important issue by most. Should transfer stations provide for all waste disposal needs at one site, or should the

responsibility for this component lie with the generators by requiring direct-haul to a disposal facility? Alternately, a semi-annual special collection bin could be provided to target bulky goods. Another difficult waste, particularly in ranching country and areas of intense hunting activity, is animal carcasses and related wastes.

g) Liquid and Hazardous Wastes

The general consensus was that liquid and hazardous waste should not be accepted at a transfer station. Public education should be used to avert problems. Regional districts should avoid the issue.

h) Environmental Contamination

Water should be contained and prevented from contacting garbage. Setback limits to water bodies should be defined. Most regional representatives did not feel that environmental contamination was a major issue of concern at transfer stations; it was frequently stated that if a station is properly designed and maintained, the potential for environmental contamination would be limited. Comments often followed suggesting that in order to have a properly designed and operated station, there has to be a corresponding willingness to provide the necessary funding, which is often not available.

i) Waste Hauling

Hauling issues of concern tended to focus on the mechanics of hauling while considering economics. Identified issues included investigating the transport of compacted and uncompacted waste, the type of service route needed, the impacts of hauling, and how to plan truck routing. The use of a packer truck instead of a transfer station was suggested as a reasonable solution for the Gulf Islands.

In Alberta, waste hauling problems were related to heavy, bulky materials jamming bins or making them too heavy, and to light, bulky wastes such as cardboard boxes occupying too much bin space, resulting in inefficient loading. These problems may be resolved by providing temporary or full time supervision, or by limiting hours of operation. Public information programs can also help. Overfilling of bins is a problem that indicates the need for more frequent bin haulage or larger bins, although if some bins are overfilled while others are empty, a need for supervision is indicated.

j) Winter Access and Snow

Snow covered bin lids can be very heavy and difficult to open. A heavy snowfall can make it difficult to remove a full bin. Both users and haulers must have access to the bins without requiring excessive extra effort.

k) Wildlife

Again, in some areas of the province, garbage-conditioned bears and other large predators such as wolves and coyotes pose a real threat at solid waste facilities. The problem of bears trapped inside transfer containers was mentioned, to illustrate the need for bear-proof containers. Users must have access to the disposal facility, while bears and other large predators must be kept out. There are a number of different measures available to mitigate predator problems, including predator-proof lids and electric fencing. Managing for bears, perhaps the most common of the large predators encountered, will also limit problems with other wildlife, including scavengers. Maintaining a clean site will discourage wildlife in general.

l) Education and Publicity

When solid waste managers are deciding what role transfer stations should have in their community, they should have information available to effectively determine this. Publicity and promotion is of particular concern when a landfill is replaced by a transfer station, and the public should be provided with reasons for making the change. Education and promotion should be used to discourage improper disposal behaviour and can limit the potential for the disposal of undesirable materials.

m) Vandalism

In areas which have opposed a transfer station, vandalism has been a problem. Experience in Alberta has indicated that vandalism is diminished at stations that are highly visible to the public. Public education, site supervision, and limited hours of operation can help resolve vandalism problems.

n) Fires

Fires may be set deliberately, as an act of vandalism, or unintentionally, for example through the disposal of hot ashes. The latter problem was resolved in the Peace River Regional District through a public notice sent to all residents in the area. Public education has also been found to be effective in Alberta, as has increased site supervision.

o) Odours

Frequent emptying of the bins was seen as one way to mitigate odour complaints.

p) Litter

Several representatives saw a need to enclose the transfer site to contain wind blown debris. It was suggested that haul trucks should be properly covered. In Alberta, litter problems at transfer stations have been reduced by public education programs and increased site supervision.

q) Dust

At larger sites, dust control measures may be needed.

r) Costs

Costs are related to the type of facility and climatic conditions. Only order of magnitude cost estimates are needed. It was suggested that other publicly funded agencies be considered to augment a collection/transfer service, for example, the Ministries of Highways, Parks, and Forests frequently employ their own staff or contractors to collect waste.

s) Public Concern

In Alberta, it was found that public concerns were allayed through education, by providing a clean, tidy service, and by providing the opportunity to recycle at the transfer station.