

THE SIGN ELEVATION SHOWN BELOW IS INTENDED TO SHOW GENERAL ASSEMBLY ONLY. THE EXACT LENGTHS AND SPACINGS OF VERTICAL ANGLES AND HORIZONTAL SIGN SUPPORTS SHALL BE SPECIFIC TO EACH SIGN SIZE.

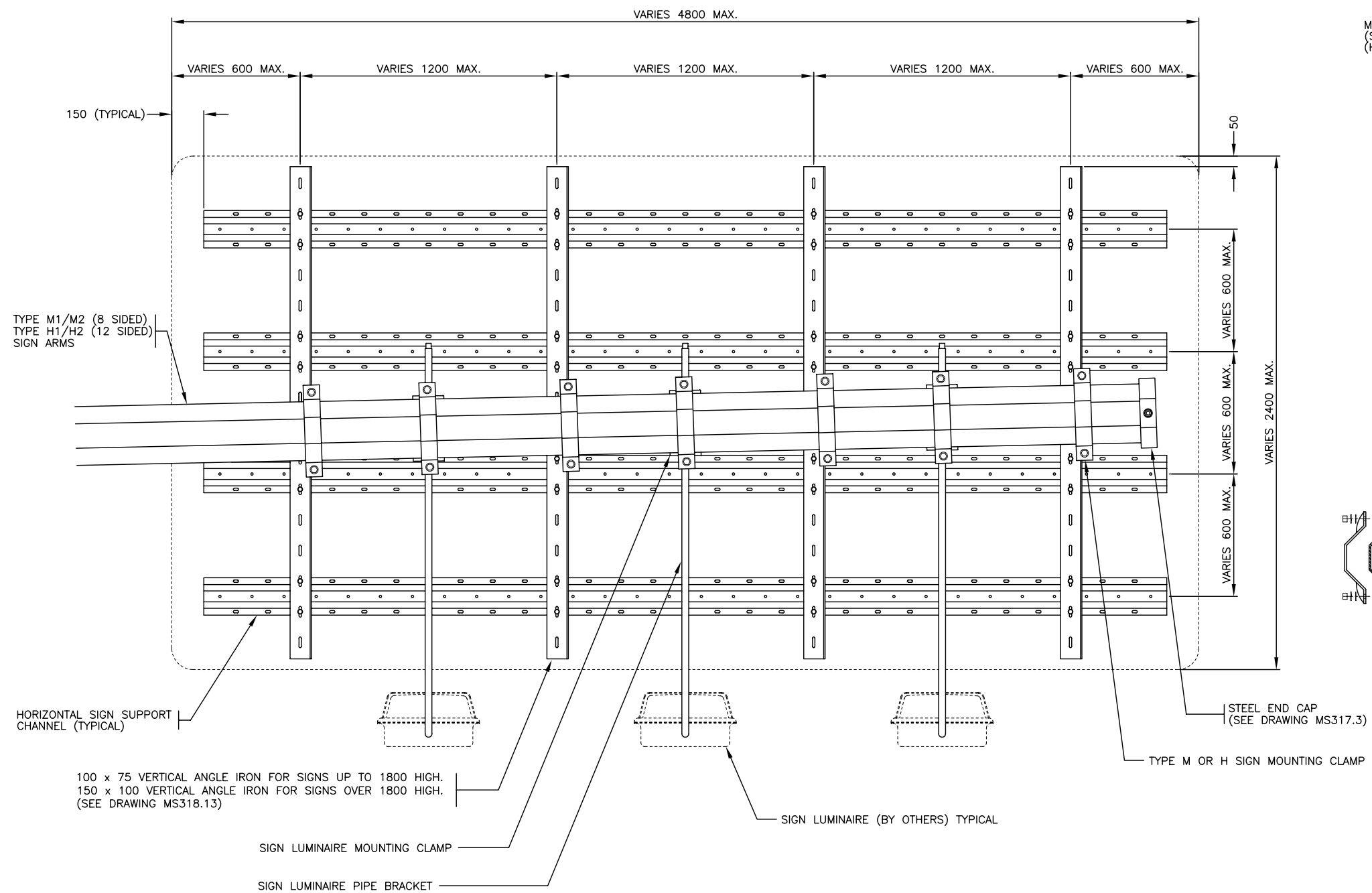

PLYWOOD SIGN AND SIGN LUMINAIRE MOUNTING DETAILS – REAR VIEW

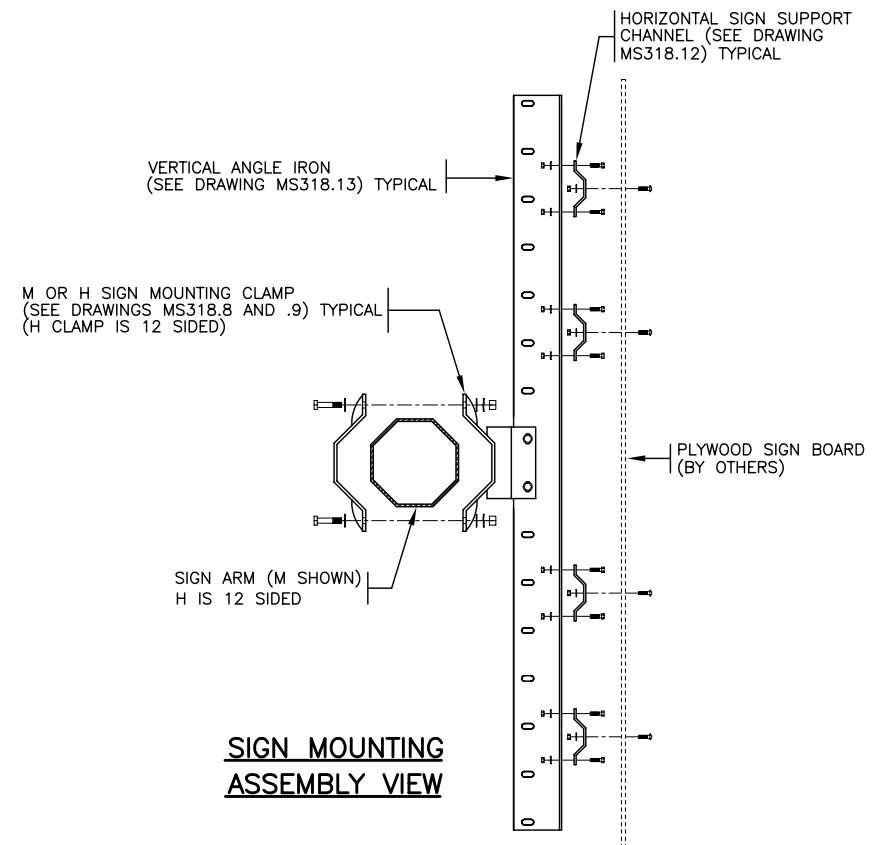

SIGN MOUNTING ASSEMBLY VIEW

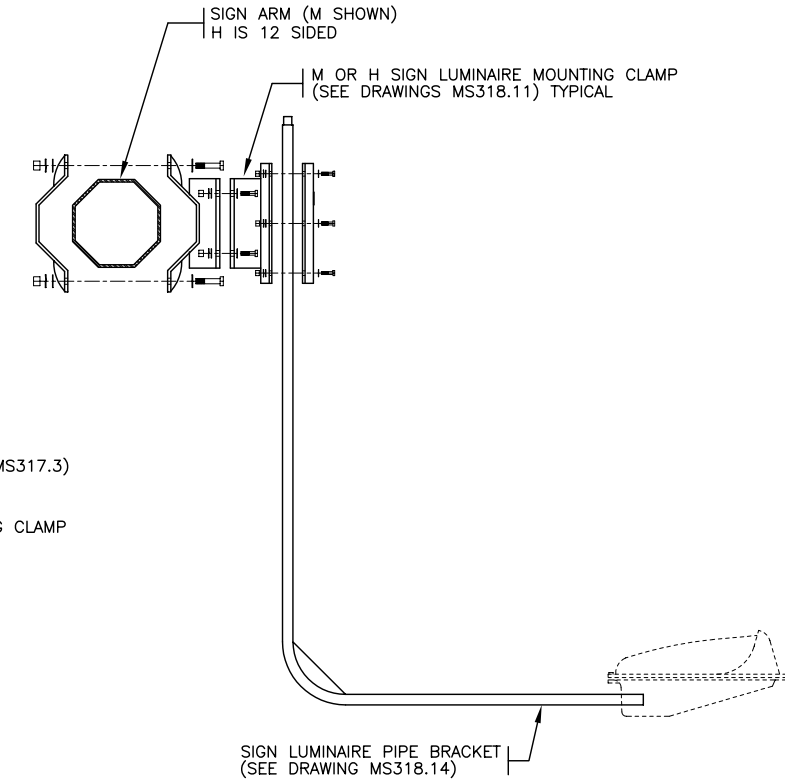

SIGN LUMINAIRE MOUNTING ASSEMBLY VIEW

- NOTES**
- SEE MATERIAL STANDARD SPECIFICATIONS CHAPTER 301 – TRAFFIC SIGNAL, LUMINAIRE, AND SIGN POLE STRUCTURES FOR ADDITIONAL INFORMATION.
 - ALL DIMENSIONS ARE IN MILLIMETRES UNLESS OTHERWISE NOTED.
 - 'SN' DENOTES MINISTRY STOCK NUMBER.
 - THE POLE MANUFACTURER SHALL SUPPLY A SKETCH DETAILING THE EXACT SPACING OF VERTICAL, HORIZONTAL AND SIGN LUMINAIRES FOR EACH SIGN. THESE SKETCHES SHALL BE PACKAGED WITH THE SIGN SUPPORTS.

NOT TO SCALE

No.	Description	Date
J		
I		
H		
G		
F		
E		
D		
C		
B	PIPE BRACKET MOVED TO OPPOSITE SIDE OF ARM	NOV96
A	GENERAL REVISIONS	AUG96

TYPE M AND H SIGN MOUNTING BRACKETS FOR PLYWOOD SIGNS

ASSEMBLY DETAILS

Ministry of Transportation and Highways

Drawing No. **MS318.5**

