

TYPE (M) SHAFT BASE - SIDE VIEW

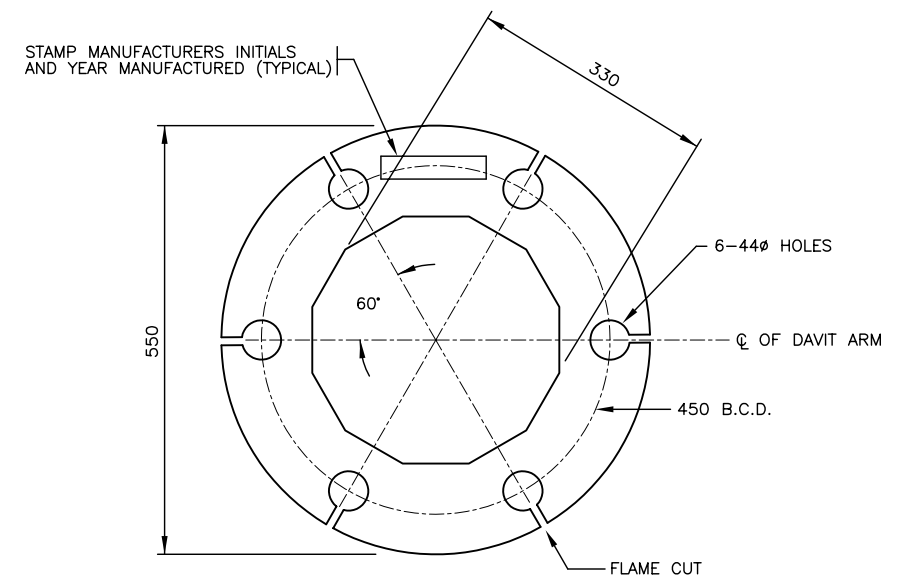

TYPE (M) BASE PLATE - PLAN VIEW

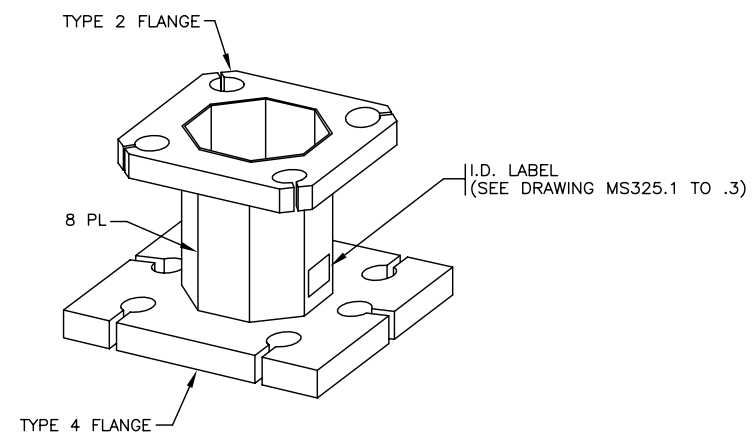

TYPE 4 TO TYPE 2 FLANGE ADAPTOR

SEE DRAWING MS312.1 FOR NOTES

NOT TO SCALE

No.	Description	Date
J		
I		
H		
G		
F		
E		
D		
C		
B		
A		

TYPE M SHAFTS, ARMS AND EXTENSIONS		
BASE PLATE AND FLANGE ADAPTOR DETAILS		
	Ministry of Transportation and Highways	Drawing No. MS312.2